

LK 162 SmartStove®

- With the alarm function in case of over temperature, you can enjoy the warmth without worrying



Technical Data

Voltage:	230 VAC, 50 Hz
Power consumption:	3,5 VA
Relay output:	Max. 240 VAC, 4 A
Triac outputs:	230 VAC ± 10%, 1 A, 200 VA
High-efficiency pump:	Analog output 0 -10 V, max. 10 mA PWM output 100 Hz - 2 kHz
Sensors:	PT 1000
Display:	TFT backlit colour display, 47 x 35 mm
Protection type:	IP 20
Protection class:	II
Approvals:	CE



LK 162 SmartStove® is a biomass controller for multi-fuel water containing stoves with buffer tanks. The controller has a number of preset hydraulic systems for different installations.

For indication of the active hydraulic system and the current temperatures in stove and buffer tank the controller is equipped with a coloured full graphics display which is permanently backlit.

LK 162 SmartStove® can control the charge pump of a loading unit, the circulator in a heating loop, high-efficiency pumps and an additional heat source.

FEATURES

- Acoustic alarm and indication in the display if over temperature should occur in stove or buffer tank
- A temperature sensor in the stove controls the charge pump of the loading unit which means that no fluegas thermostat is needed
- Pump delay function. The charge pump in the loading unit does not start until the stove has reached a certain temperature. This saves energy, prevents tarring and considerably prolongs the life-time of the stove
- Dynamic pump control can be activated when the loading unit is equipped with a speed-controlled pump. The pumpcontrol keeps the flow at a constant temperature
- Economy or comfort mode can be selected to optimize energy efficiency in the potable hot water boiler and/or in the heating system



- Controls an additional heat source
- Delay function for the additional heat source
- 7 hydraulic systems which can be mirrored
- 2 outputs for speed-controlled pumps with PWM and/ or analogue signal
- 6 terminals for temperature sensors
- 1 floating change-over contact
- SD card slot for data logging and software update
- Legionella prevention
- Pump exercise
- Freeze protection

Hydraulic System

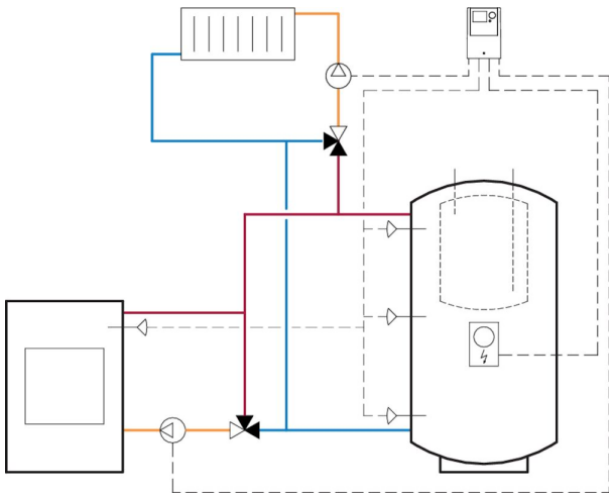

Hydraulic System

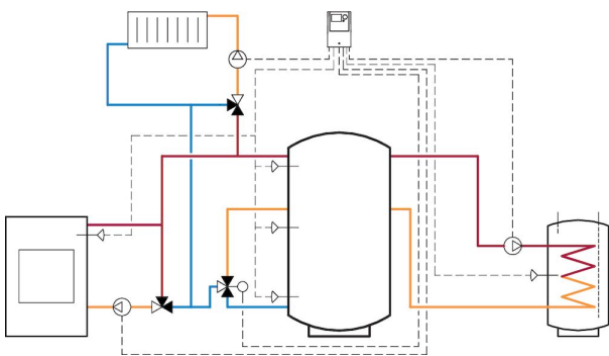

LK 162 SmartStove®

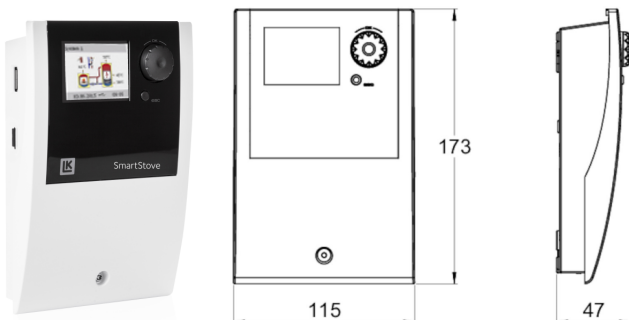

Article	Type	Weight (kg)
181708	LK 162 SmartStove®	0.7

Four sensors included (PT 1000 - 4 m cable).

Accessories & Spare parts

Article no.	Article	Position
181186	Tank sensor PT 1000 Ø 6 mm - 4 m cable	1
180812	Sensor pocket 150 mm	2

