

**reventon**  
INDUSTRIAL SOLUTIONS

# Technical datasheet

AIR WATER HEATER FARMER OPENAIR IP66



- 1. INTRODUCTION
  - 1.1 GENERAL INFORMATION
  - 1.2 STORAGE AND TRANSPORT
  - 1.3 PACKAGE CONTENT
  - 1.4 APPLICATION
- 2. DEVICE CHARACTERISTIC
  - 2.1 PROTECTION DEGREE IP
  - 2.2 CONSTRUCTION AND PRINCIPLE OF OPERATION
  - 2.3 ANTI-CORROSION COATING
  - 2.4 DIMENSIONS
  - 2.5 TECHNICAL DATA
- 3. ASSEMBLY
  - 3.1 GENERAL PRINCIPLES
  - 3.2 HORIZONTAL ASSEMBLY (WALL MOUNTING)
  - 3.3 VERTICAL ASSEMBLY (CEILING MOUNTING)
  - 3.4 DIFFUSER 360° REPLACEMENT
- 4. INSTALLATION
  - 4.1 CONNECTION TO HEATING INSTALLATION
  - 4.2 CONNECTION TO ELECTRICAL INSTALLATION
- 5. EXPLOITATION
  - 5.1 EXPLOITATION PRINCIPLES
  - 5.2 OPENING AND CLEANING
- 6. CONTROLS
- 7. WIRING DIAGRAMS
- 8. WARRANTY TERMS

**1. INTRODUCTION**

Thank you very much for purchasing the air water heater FARMER OPENAIR. Please read and keep this manual for future reference of users and operators.

**1.1 GENERAL INFORMATION**

The owner and the user of unit Reventon brand should read carefully this instruction and follow included guidelines. In case of any doubts, please reach out directly to the producer i. e. company Reventon Group Sp. z o. o. [Ltd.]. The contact data are given at the section 8 (subsection XVII).

 The key recommendations from safety point of view are marked with the warning triangle (like the one on the left). It enables quick and easy localization of these recommendations and remind of them before interference with the unit.

 During installation, usage or maintenance of the heater, all local safety requirements must be respected.

The owner and each user of unit must be familiar with the Warranty Terms included in the section 8 of this instruction and follow its guidelines. In case of any doubts regarding warranty points, please reach out immediately to the company Reventon Group Sp. z o. o. [Ltd.] before taking any action.

The producer reserves the rights to make changes in the technical documentation without previous notice.

**1.2 STORAGE AND TRANSPORT**

The product must be stored and transported on an appropriate pallet, in ambient temperature ranging from -20°C to 50°C and relative humidity ≤ 80%.

 During carrying of the heater, it must not be held by the coil's connectors.

During collection of the heater, please check the device exactly to exclude any transport damages. If any is observed, the damage report in presence of the item supplier must be filled. Such report is the basement for transport complaint. The damage report must be provided by the carrier.

 Due to its weight, the heater should be handled by two people.

**1.3 PACKAGE CONTENT**

- heater FARMER OPENAIR
- technical documentation including Warranty Card

**1.4 APPLICATION**

The heating device FARMER OPENAIR is design for internal usage (i. e. inside buildings). It can be used for the heating of rooms where are aggressive conditions like high dustiness or high concentrations of acids, ammonia etc. in the air. However, the heater should not be used in environments which are highly corrosive for aluminium, copper or steel and in environments which contain aggressive compounds not listed in the table in the section 2.3 or compounds with concentrations in the air

higher than the values given in this table. The device cannot be also used in places, where it would be exposed to too high humid (relative humidity higher than 90%) or direct contact with water, exceeding the permissible contact due to the protection degree IP (see next section).

**2. DEVICE CHARACTERISTIC**

**2.1 PROTECTION DEGREE IP**

IP determines the tightness of the electrical device (like fan motor), which is defined by two digits:

- **first characteristic digit** - specifies protection of the device against direct access to its interior as well as against penetration of smaller solids (such as dust)
- **second characteristic digit** - determines resistance of the engine to water ingress, i. e. its waterproofness

The motor of the fan used in FARMER OPENAIR with IP 66 has the following protection:

- protection against access to hazardous parts by wire with a diameter of 1 mm or more and against dust (total dust tightness)
- protection against stream of the water up to 100 l/min from any direction

**2.2 CONSTRUCTION AND PRINCIPLE OF OPERATION**

**Laminate housing:** as the name suggest, it is made of laminate covered with gelcoat. Additionally reinforced with the frame made of stainless steel, to which the fan is screwed. The housing is connected to the frame of the heat exchanger with the hinges and the clamps, what enables opening of the heater for the periodic cleaning.

**Diffuser 360°:** made of powder coated galvanised steel. Depending on the opening (deflection) of its stators, it is possible to achieve strong turbulences and in consequence better mixing with surrounding air (for deflection 20°), longer and more uniform stream (for deflection 90°) or all intermediate stages (for angles between 20° and 90°).

 The stators have to be deflected at least 20° before the start up of the fan.

**Heat exchanger (coil):** made of copper (the tubes), aluminium (the lamellae) and galvanised steel (the frame). The lamellae and the tubes are additionally covered with anticorrosive epoxy coating. Supplied by a heating medium, which circulates through the coil and releases heat to the flowing air. The exchanger is adapted to operate in dusty conditions - it has bigger distance between the particular lamellae what delays clogging of it and necessity of cleaning.

**Axial blowing fan:** made of powder coated steel. The fan provides the air flow through the heat exchanger and further into the room. It has a single phase motor with protection rating IP 66. The fan was undergone the 240-hour salt spray test according to ISO 9227:2006.

**2.3 ANTI-CORROSION COATING**

The heat exchanger of heaters FARMER series are covered with an additional epoxy coating. It protects the metal surfaces against the negative influence of humid, salt and acid environments. The epoxy layer was undergone the salt spray test according to ASTM B 117.

COMPOUND	IMMUNITY
Trichlorethylene	Excellent/Good
Methyl Ethyl Ketone (MEK)	100 ppm
Acids (2% HCL, 2% H <sub>2</sub> SO <sub>4</sub> )	Excellent/Good
Salt spray	Excellent/Good
Steam ( 121°C / 30 min)	Excellent

**2.4 DIMENSIONS**

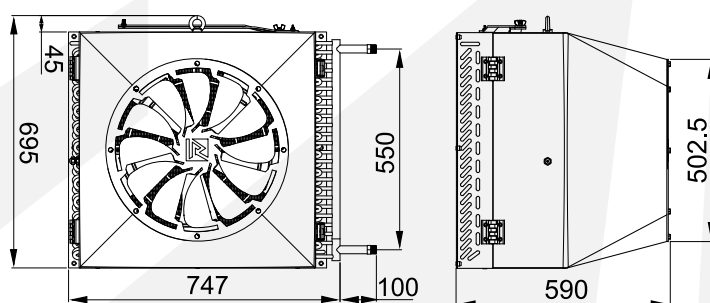

## 2.5 TECHNICAL DATA

MODEL Product code	FARMER OPENAIR IP66 WHHCFO-2042
Maximal airflow [m³/h]	5100
Maximal isothermal stream range [m]	25
Heating capacity [kW]*	54.3
Heating capacities range [kW]**	7.5 – 71.6
Number of rows [-]	3
Water capacity [dm³]	3,8
Maximal temperature of heating fluid [°C]	120
Maximal pressure of heating fluid [MPa]	1.6
Connectors diameter["]	3/4
Voltage [V] / Frequency [Hz]	230 / 50
Nominal motor current [A]	2.2
Nominal motor power [W]	500
Nominal motor speed [rpm]	1395
IP protection rating of motor [-]	66
Net weight [kg]	46
Noise [dB]***	66

\* for the water parameters 90/70°C and the inlet air temperature 0°C

\*\* the max. capacity for 120/90°C, 0°C the inlet air temperature // the min. capacity for 40/30°C, 20°C the inlet air temperature

\*\*\* the measurement at the distance of 5 m from the device

## 3. ASSEMBLY

### 3.1 GENERAL PRINCIPLES

**!** The heater should be assembled by people experienced in mounting of such devices and - if local law requires it - with appropriate qualifications.

**!** Due to the relatively large weight and the dimensions of the heater, the assembly should be performed by at least two people and at least one of them must meet the requirements in the paragraph above.

**!** It is the responsibility of the assemblers to make the mounting according to the guidelines from this instruction and in accordance with the local regulations in force.

After mounting of the device, the assembler is obliged to fill out the Warranty Card (positions 1 and 2). It is also treated as a guarantee, that the assembly was made in accordance with the requirements. The Warranty Card is included in this manual under the Warranty Terms.

**!** During carrying of the heater, it must not be held by the coil's connectors.

**!** Before starting the assembly, make sure that the housing clamps are closed and the wing nuts of the arm are tightened.

The heater should be mounted in way providing the horizontal or the vertical air stream, keeping the minimum gaps shown in the drawing at the end of this section.

In case of horizontal stream, it is recommended to use the horizontal diffuser (product code HDFO-2045) instead of the diffuser 360°. The description of the diffuser replacement is given in the section 3.4.

During the assembly, the optimal location of the heat exchanger connectors and the possibility of safe opening of the device must be taken into account.

**!** The heater must be mounted using elements with a load capacity appropriate to its weight.

**!** In the case of the horizontal assembly, use the holes in the heat exchanger frame and the eye bolt in the laminate housing (i. e. both the frame and the housing should be installed independently of each other - see example in the section 3.2).

**!** The stators must be deflected at least 20° before the start up of the fan.

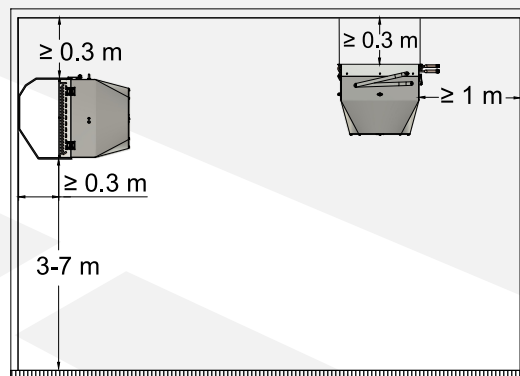

MODEL	FARMER OPENAIR				
Heating water temperatures [°C]	80/60				
Inlet air temperature [°C]	8	12	16	20	32
Heating capacity [kW]	40.6	37.6	34.6	31.7	22.9
Outlet air temperature [°C]	30.7	33.3	35.9	38.4	45.8
Water flow [m³/h]	1.8	1.7	1.5	1.4	1.0
Water flow resistance [kPa]	10.4	9.0	7.6	6.5	3.5

MODEL	FARMER OPENAIR				
Heating water temperatures [°C]	70/50				
Inlet air temperature [°C]	8	12	16	20	32
Heating capacity [kW]	33.1	30.1	27.2	24.2	15.5
Outlet air temperature [°C]	26.5	29.1	31.6	34.1	41.3
Water flow [m³/h]	1.5	1.3	1.2	1.1	0.2
Water flow resistance [kPa]	7.1	5.9	4.9	3.9	1.7

MODEL	FARMER OPENAIR				
Heating water temperatures [°C]	65/45				
Inlet air temperature [°C]	8	12	16	20	32
Heating capacity [kW]	29.3	26.3	23.4	20.5	10.9
Outlet air temperature [°C]	24.4	26.9	29.4	31.9	38.6
Water flow [m³/h]	1.3	1.2	1.0	0.9	0.2
Water flow resistance [kPa]	5.7	4.7	3.7	2.9	0.9

MODEL	FARMER OPENAIR				
Heating water temperatures [°C]	60/40				
Inlet air temperature [°C]	8	12	16	20	32
Heating capacity [kW]	25.5	22.6	19.6	16.6	6.6
Outlet air temperature [°C]	22.3	24.8	27.3	29.6	36.0
Water flow [m³/h]	1.1	1.0	0.9	0.7	0.1
Water flow resistance [kPa]	4.4	3.5	2.7	2.0	0.3

MODEL	FARMER OPENAIR				
Heating water temperatures [°C]	55/45				
Inlet air temperature [°C]	8	12	16	20	32
Heating capacity [kW]	27.8	24.8	21.9	19.0	10.4
Outlet air temperature [°C]	23.5	26.0	28.5	31.0	38.3
Water flow [m³/h]	2.4	2.2	1.9	1.7	0.3
Water flow resistance [kPa]	19.2	15.5	12.2	9.4	3.0

MODEL	FARMER OPENAIR				
Heating water temperatures [°C]	40/30				
Inlet air temperature [°C]	8	12	16	20	32
Heating capacity [kW]	16.6	13.7	10.8	7.5	-
Outlet air temperature [°C]	17.3	19.8	22.2	24.3	-
Water flow [m³/h]	1.4	1.2	0.9	0.7	-
Water flow resistance [kPa]	7.5	5.2	3.3	1.7	-

### 3.2 HORIZONTAL ASSEMBLY (WALL MOUNTING)

The example below shows the wall mounting with the rotating mounting bracket (product code RHFO-2044) and a chain sling with a hook.

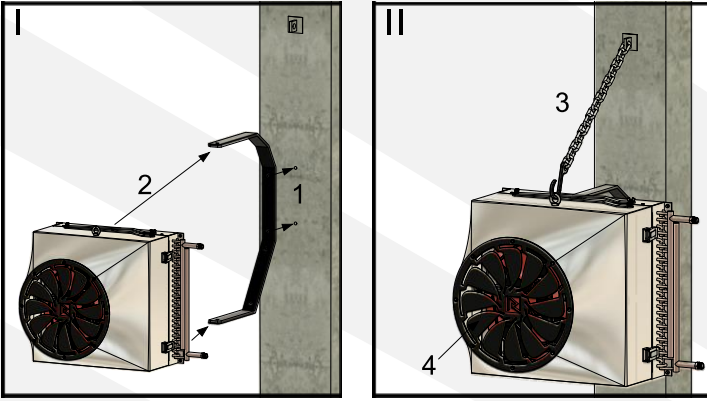

1 - The rotating mounting bracket should be attached to a partition with the appropriate load capacity (see the net weight of the heater in the section 2.5) with e. g. mounting pins and screws M8 x 25 mm (or longer).

2 - Hang the heater on the rotating mounting bracket using the M8 bolts and washers (between the bracket and the heater). Then turn the device on the bracket according to a required position and tighten the screws securely.

3 - Using e.g. a chain sling with a hook, suspend the device with eye bolt in the housing too. The chain has not to be slack - it should carry a part of the heater weight. The hook itself should be easily detachable to enable opening of the device (see section 5.2.I).

4 - Deflect the blades of the diffuser blades 360° at angle, which allows to achieve the required stream shape (minimum 20°).

### 3.3 VERTICAL ASSEMBLY (CEILING MOUNTING)

The example below shows the ceiling mounting with a chain sling and a hook.

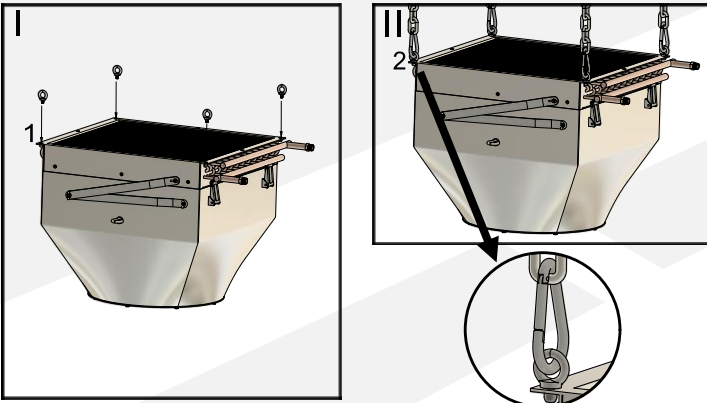

1 - Screw the M8 eye bolts into the rivet nuts installed in the exchanger frame. The thread of these bolts should be longer than the rivet nut and as the preventive measure the bolts can be locked with nuts from the bottom.

2 - Hang the device on the hooks of the chain slings. None of the chains should be slack - each should carry a part of the heater weight. The slings have to be attached to a partition with the sufficient load capacity to support the weight of the heater (see weight in 2.5).

### 3.4 DIFFUSER 360° REPLACEMENT

In the case of the wall mounting of the heater with the horizontal stream, it is recommended to use horizontal diffuser (product code HDFO-2045). The procedure for self-replacement of the diffuser is described below.

**!** The replacement of the diffuser must be done by a person familiar with this technical documentation and before the replacement unit has to be disconnected from the electrical system.

Due to the need of holding the bolt heads during unscrewing and tightening the nuts, it is recommended to replace the diffuser by two people.

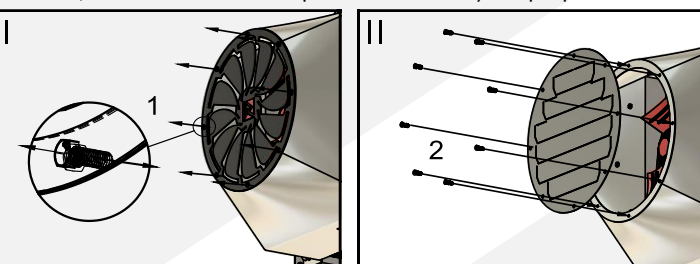

1 - After opening the heater (according to the section 5.2.I), unscrew the nuts of the screws mounting the diffuser 360° to the laminate housing from the fan side. The screw heads on the other side should be hold by a second person.

2 - In the same way, put the horizontal diffuser on and tighten it. Then close the device, not forgetting to screw the wing nuts.

### 4. INSTALLATION

**!** Before connecting the unit to an electrical installation, it must be assembled permanently to a suitable partition (according to the recommendations contained in the section 3).

**!** All installation, repairs and disassembly works, must be performed by qualified persons i. e. having the appropriate qualifications for these works. It is the responsibility of the installer to make the installation according to the guidelines from this instruction and in accordance with the local regulations in force.

After connecting to the heating or electric installations, the installer is obliged to make an entry in the Warranty Card, confirmed by a stamp and signature (positions 3 and 4). It is also treated as a guarantee, that the installation was made in accordance with the requirements of this point 4. The Warranty Card is included in this manual under the Warranty Terms in the section 8.

#### 4.1 CONNECTION TO HEATING INSTALLATION

The pipes should be connected in accordance with the indicators on the heater (supply - marked in red, return - marked in blue).

**!** Connecting the device to the hydraulic installation, do remember to hold the connectors by a pipe wrench - like it is shown in graphic. Not keeping to this recommendation may cause the damages of the coil.

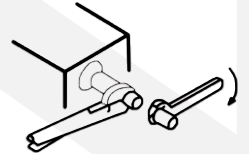

It is recommended to use the following installation fittings:

- cut off valves on the supply and return pipes
- vent valve in the highest place of the hydraulic installation

**!** The hydraulic system should include all safety elements required by law (depending on the type of central heating installation and the type of heat source).

**!** Before connecting the heater to an electrical installation, the leakage test of the hydraulic installation should be conducted.

#### 4.2 CONNECTION TO ELECTRICAL INSTALLATION

**!** The electrical connection of heater to an installation with the electrical parameters according to the section 2.5) should be made in according to the appropriate connection diagram (see section 7).

As the power cable, it is recommended to use a three-core cable with a 1.5 mm<sup>2</sup> cross-section with earthing.

**!** The supply wire to the junction box of the fan should be led through the cable gland installed in the housing. The wire should be routed along the fan mounting grid and it should be mounted with clamps to this grid in several places, in way preventing the situation in which operating fan could interfere with the wire and damage its insulation. An example of the wire running is shown below.

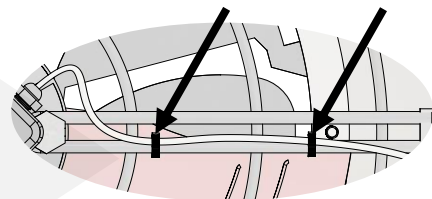

**!** The electrical installation should include all safety elements required by the law and the ON/OFF switch enabling safe disconnection of the heater from the electrical system.

**!** Before the start up, it is required to check the electrical installation in terms of damaged insulation, incorrect connection in the terminals, risk of potential short circuits etc.

### 5. EXPLOITATION

#### 5.1 EXPLOITATION PRINCIPLES

**!** The user is obliged to be familiar with this instruction before exploitation of the device.

**!** Before any interference in the device, the electricity supply to the heater must be absolutely cut off.

**!** Access to the device by parties like unauthorised people, children and animals is forbidden and should be prevented or at least hindered.

**!** Operation of the open device is forbidden - before turning on the heater, make sure that the housing clamps are closed.

**!** The device cannot work with covered or restricted air inlet or outlet (e.g. as a result of not keeping the minimum distances from partitions or obstructed inlet/outlet).

 The unit is designed for handling of air at temperature ranging from -20°C to 60°C and with relative humidity ≤ 90%.

 The heater has no antifreeze protection – as the heating medium should be used a fluid with a lower freezing point than the lowest probable temperature that may occur in the particular room.

 In case of any malfunctions in the operation of the heater, immediately cut off the device from the electrical system and contact directly with the producer or the distributor.

 If the device is not used for a longer time disconnect the unit from the electrical installation.

 The device should be serviced periodically, at least once a month, as follows:

- blow out the heat exchanger with the compressed air (according to the instructions in the section 5.2)
- clean the remaining elements from residue with a soft cloth

 The heater must be maintained by a user who is familiar with this instruction or by an external entity if due to the way of assembly or local regulations additional authorisations like e. g. working at heights are required. Before starting any maintenance work, the heater must be disconnected from the power supply.

 The frequency of the service should depend on the actual dirtiness - if the heater is operating in a room with a high concentration of dust, periodic cleaning should be performed much more often than once a month to prevent "clogging" of the coil.

After exploitation time, please utilise the unit according to the local regulations.

## 5.2 OPENING AND CLEANING

In order to thoroughly clean the heat exchanger, the device should be open. The procedure of the safe opening the heater assembled horizontally (I) and cleaning recommendations (II) are given below.

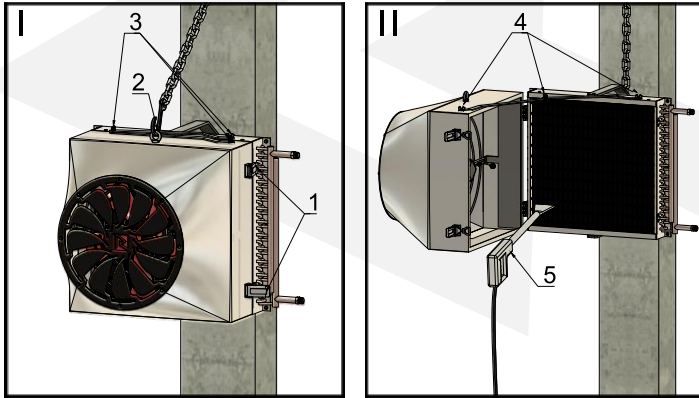

1 - Open the clamps.

2 - Unhook the chain sling.

3 - Slightly loosen the three wing nuts so that the device opens slowly. The straightening arm should resist - do not loosen the nuts too much. During opening, the arm should also not rub against the housing's surface. The heater can be open up to 90° (when the arm is straight).

 During the opening the laminate housing must be still keep by the opener up to the wing nuts are again tighten (see next step).

4 - When the unit is open, the wing nuts must be tighten to block the open housing with the arm.

5 - The heat exchanger should be blow up with the compressed air. It is recommended to blow out the coil from both sides.

After cleaning the heat exchanger, close the device in the same way as following: loosen the wing nuts, carefully close the housing, close the clamps, tighten the wing nuts of the folded arm and hook the chain sling. If the sling chain is slack, tighten it again.

## 6. CONTROLS

Using of control dedicated to FARMER OPENAIR gives vast possibilities of adjusting the efficiency of the unit in different degree of automation, depending on the needs.

### PROGRAMMABLE CONTROLLER HMI SINGLE

The controller is used to regulate devices equipped with 1-stage fans. It is an advanced controller with many functions i. a. operation in heating, cooling or mixed mode, programmable mode, valve control, automatic selection of the fan speed. Together with the controller the external sensor is provided, which allows to read the temperature in the required place, even remote from the controller. In addition, the device can operate

in one of two modes - thermostatic or temperature difference. The second one enables effective controlling of destratification fans. The controller can be integrated with the BMS building control system (using the MODBUS communication protocol).



Voltage / Frequency: 230 V AC / 50 - 60 Hz  
Maximum current load: 5 A  
Operating temperature range: 0 - 45°C  
Regulation range: 5°C - 35°C  
Regulation accuracy: 0,5°C  
External temperature sensor: NTC 10K  
Communication (BMS): RS485  
Dimensions: 86 x 86 x 13,3 mm  
Weight: 0,27 kg  
Degree of protection (housing): IP 20  
Degree of protection (external sensor): IP 68

### FAN SPEED CONTROLLER HC

The controller is designed to change the single-phase fan's speed voltage controlled in industrial and heating systems. The item has the 5-level knob which enables to change the supply voltage - level 1 represents the lowest voltage while level 5 represents the nominal voltage (i. e. 230 V). The levels 2-4 represents the intermediate vales of voltages. The selection of the appropriate model depends on the number of the devices that have to be connected to the to one regulator - the total intensity of the connected devices cannot exceed the maximum current flow of the regulator.



5 control levels: 80-105-135-170-230 V\*  
Voltage / Frequency: 230 V AC / 50 - 60 Hz  
Maximum current load (depending on model):  
1,2 A, 3 A, 5 A, 7 A or 14 A  
Protection: thermal switch  
Weight (depending on model):  
1,45 kg, 2,5 kg, 4,5 kg, 5,5 kg or 10,5 kg  
Degree of protection (housing): IP 54

\* regulation for the regulator 3A: 70-85-105-145-230 V

### MANUAL THERMOSTAT HC

The thermostat controls operation of the heater - it switches the unit off automatically when the set temperature is reached. The thermostat can control in heating or cooling mode.



Voltage / Frequency: 230 V AC / 50 - 60 Hz  
Maximum current load: 3 A  
Operating temperature range: 0 - 40°C  
Regulation range: 10 - 30°C  
Regulation accuracy: <1°C  
Degree of protection (housing): IP 30

### RELAY MODULE RM-16A

The relay enables to control of electricity devices (e. g. fans) which consume higher current that the permissible one for a connected regulator.



Voltage / Frequency: 230 V AC / 50 - 60 Hz  
Maximum current load: 16 A  
Inputs: dry contact NO/COM and SL voltage  
Output: relay NO/COM/NC  
Dimensions: 47 x 47 x 20 mm

### TWO-WAY VALVE WITH ACTUATOR HC 3/4"

The actuator regulates the heater's operation by closing / opening the working medium circuit.



Voltage / Frequency: 230 V AC / 50 - 60 Hz  
Power consumption of actuator: 2 VA  
Kvs coefficient of the valve: 6,3 m³/h  
Stroke: 3 mm  
Operating condition of actuator: -5°C - 60°C  
Running time: 3 - 5 min  
Degree of protection (actuator housing): IP 54

### THREE-WAY VALVE WITH ACTUATOR HC 3/4"

The actuator regulates the heater's operation by closing / opening the particular loop of working medium circuit.



Voltage / Frequency: 230 V AC / 50 - 60 Hz  
Power consumption of actuator: 7 VA  
Kvs coefficient of the valve: 6,5 m³/h  
Operating condition of actuator: 0 - 60°C  
Running time of motor (opening): 18 s  
Running time of return spring (closing): 5 s  
Degree of protection (actuator housing): IP 20

**LEGEND**

- 1 – voltage supply 230 V/50 Hz
- 2 – required protection of the electrical installation
- 3 – heater FARMER OPENAIR
- 4 – programmable controller HMI SINGLE
- 5 – external temperature sensor
- 6 – two-way valve with actuator ON/OFF

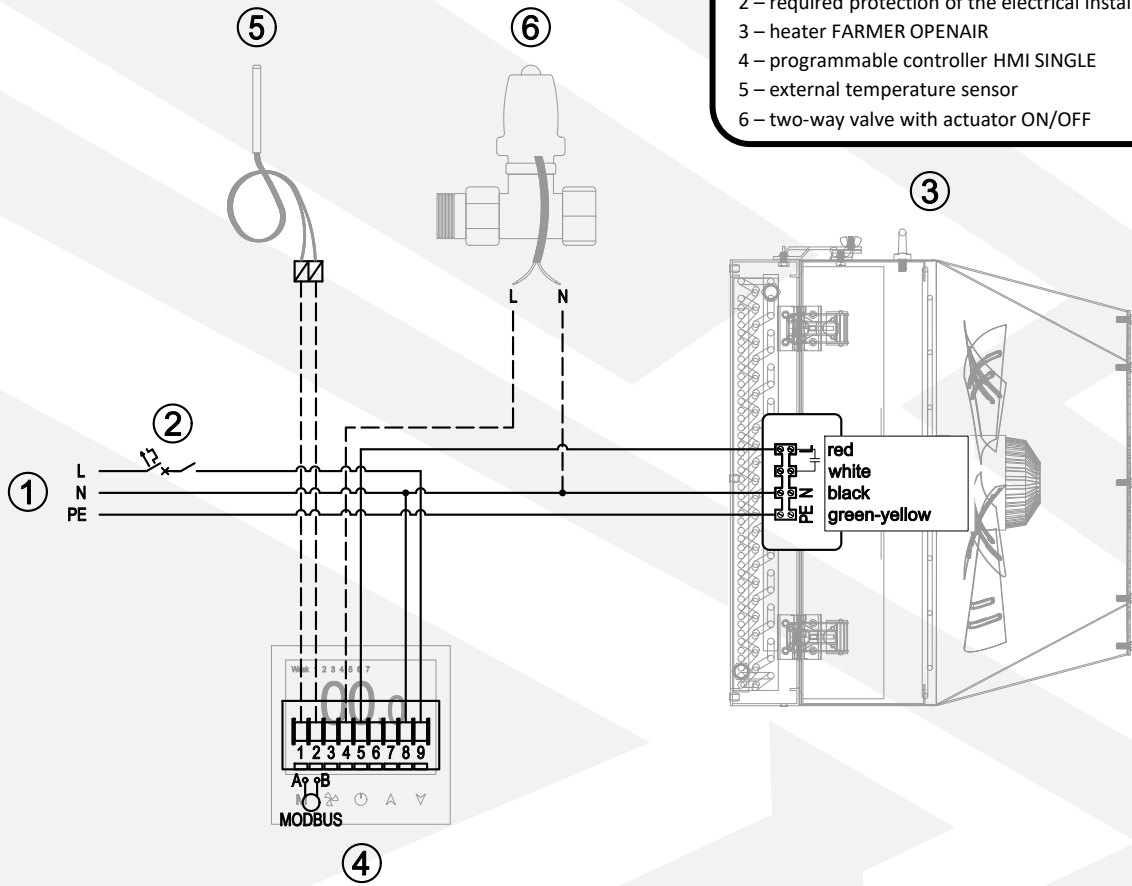

**LEGEND**

- 1 – voltage supply 230 V/50 Hz
- 2 – required protection of the electrical installation
- 3 – heater FARMER OPENAIR
- 6 – two-way valve with actuator ON/OFF
- 7 – 5-speed controller HC
- 8 – manual thermostat HC

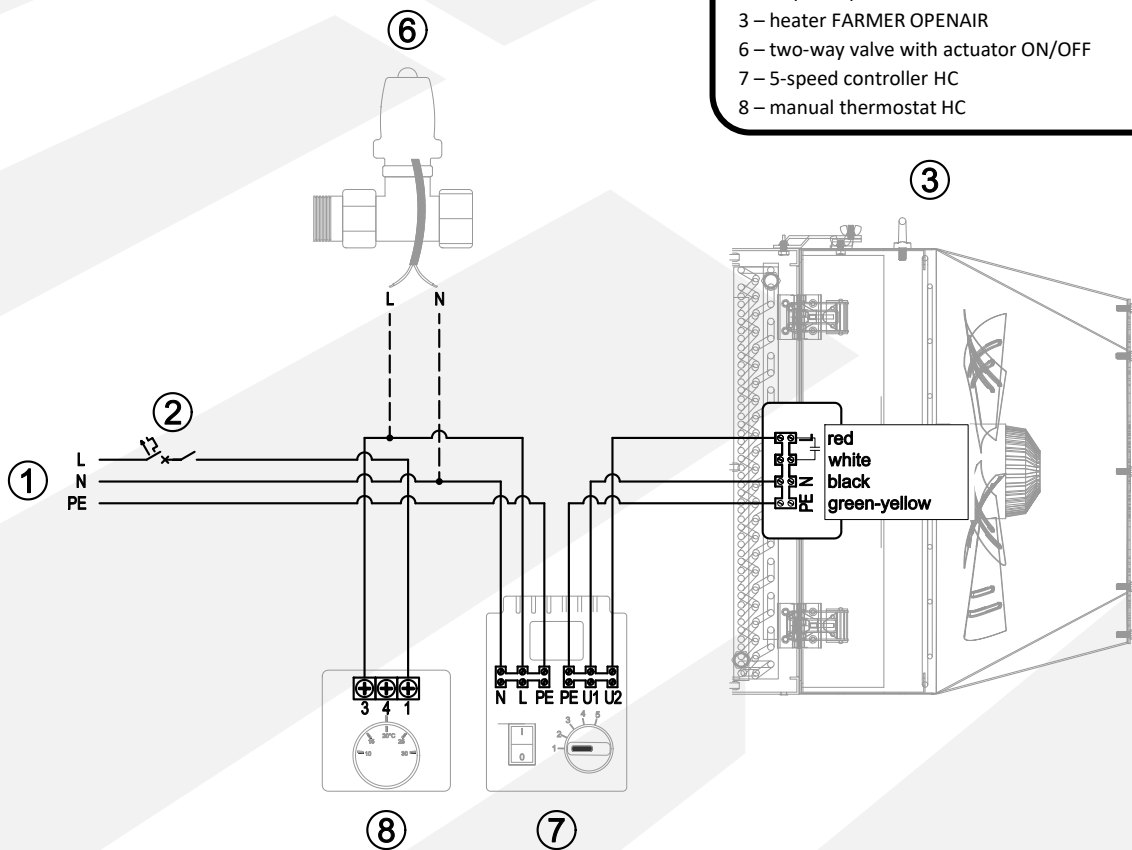

## 8. WARRANTY TERMS

I. The producer Reventon Group Sp. z o. o. [Ltd.] provides to the owner 24-month warranty protection period for the following devices:

- air water heater FARMER OPENAIR IP66

II. The warranty protection is valid from the purchasing date (i.e. the issue date of invoice) but not longer than 30 months from leaving the producer's warehouse.

III. The complaint should be sent by the complaint form on the website (<https://reventongroup.eu/en/complaints>). The scan or the photo of the fulfilled warranty card (the card is not required in case of accessories) and the purchase invoice must be attached to the form. The Warranty Card is not required in case of accessories.

IV. The producer is committed to consider the claim within 14 working days since the date of reporting (i. e. the day of receipt of the correctly fulfilled warranty form).

V. In exceptional cases, the producer reserves the right to extend the time for consideration of the request, especially if the defect is not permanent one and its determination requires a deeper analysis. The extension must be notified by the producer before the end of the 14<sup>th</sup> working day.

VI. Under the guarantee protection, the producer provides a repairment, replacement (the device or its component) or refund for the defective item within a specified time.

VII. In the case of replacement of a device component, the warranty protection of the whole unit is not prolonged.

VIII. The producer does not cover the costs of disassembly and eventual reassembly of the complaint device.

IX. The producer may decide to bring the defective device or its component to the Reventon's service. In such case the transport of the item is organised and paid by the producer. The responsibility of the device's owner is to prepare the item for the shipment - the device must be packed in a way which protects it against transport damages and the dimensions and weight of the package must not exceed 660 x 650 x 400 mm and 30 kg respectively. In the case of elements which cannot be packed in this way, the method of shipment must be agreed and approved by Reventon Group Sp. z o. o. [Ltd.]. In the case of sending a non-standard package without agreement of the producer, the producer reserves the right to charge the owner of device with all additional transport costs.

X. In the case of arrival of the authorized service of the producer or an installer to fix the complaint item, the customer must ensure them seamless access to the device and all required media like electricity, water, lighting etc. free of charge.

XI. The warranty protection does not cover the parts of the device subject to the normal usage and the following cases:

a) mechanical damage of the product

b) defects and damages through:

- improper storage or transport

- improper or non-compliant use and maintenance (i. e. inconsistent with the manual)

- using the device in the improper conditions (too high humidity, too high or too low temperature, impact of the surrounding, sun etc.)

- unauthorized (i. e. by the user or other unauthorized persons) repairs, modifications or construction changes

- connecting equipment inconsistent with the technical documentation

- connecting additional equipment, which is not recommended by the producer

- improper power supply

c) elements which wear and tear such as discolour of the housing

If there is any of the above, the claimant will be charged for transport and /or repairs.

XII. During collection of the device, the item must be checked exactly by the receiver to exclude transport damages. If any of them is observed, the damage report in presence of the supplier have to be filled - such report is the basement for transport complaint. The damage report must be provide by the carrier.

XIII. The producer does not take the responsibility for potential losses and damages related to the downtime of the device during its failure and the complaint considering.

XIV. Any changes in the Warranty Terms, improper use of the product as well as traces of self repairing (beyond the Reventon's service) or alterations cause, the warranty become invalid.

XV. These producer's Warranty Terms do not exclude or limit any rights arising from the pledge.

XVI. Not following to any of the warranty regulations makes the protection invalid.

XVII. All correspondence should be send to the following address: Reventon Group Sp. z o.o. [Ltd.], 556 Wyzwolenia Street, 43 340 Kozy, Poland or email address: [serwis@reventongroup.eu](mailto:serwis@reventongroup.eu).

## Warranty Card

<b>1 - Model and serial number* or product code</b>	<b>2 - Address and place of assembly</b>
<b>3 - Date of connection to:</b>	<b>4 - Stamp and signature of installer:</b>
Heating/cooling installation (if applicable)	
Ventilation installation (if applicable)	
Electrical installation (if applicable)	

\* serial number is required only for water heaters HC-3S, HC-EC and FARMER HCF series and recovery units INSPIRO, INSPIRO BASIC and VERTIC series

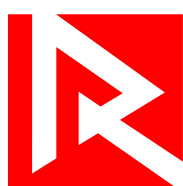

**reventon**  
INDUSTRIAL SOLUTIONS

Reventon Group Sp. z o.o. [Ltd.], 556 Wyzwolenia Street, 43-340 Kozy, Poland, [www.reventongroup.eu](http://www.reventongroup.eu)