

froling

Installation instructions

Pellet boiler PT4e 200-350 (ESP)



Translation of original German version of installation instructions for technicians!

Read and follow all instructions and safety instructions!
Errors and omissions excepted!



M2280525_en | Edition 07/07/2025

1 General	4
1.1 About this manual	4
1.2 Disposal of packaging materials	5
2 Safety	6
2.1 Hazard levels of warnings	6
2.2 Qualification of assembly staff	7
2.3 Personal protective equipment for assembly staff	7
2.4 Residual risks for installation personnel	7
3 Design Information	8
3.1 Overview of standards	8
3.1.1 General standards for heating systems	8
3.1.2 Standards for structural and safety devices	8
3.1.3 Standards for heating water	8
3.1.4 Regulations and standards for permitted fuels	9
3.2 Installation and approval	9
3.3 Installation site	9
3.4 Chimney connection/chimney system	11
3.4.1 Connection line to the chimney	12
3.4.2 Draught limiter	12
3.4.3 Measuring port	13
3.4.4 Explosion flap	13
3.5 Combustion air	14
3.5.1 General requirement	14
3.5.2 Room air-independent operation	14
3.6 Domestic hot water	16
3.7 Pressure maintenance systems	18
3.8 Return temperature control	18
3.9 Storage tank	19
3.10 Boiler ventilation	19
3.11 Installation material	19
4 Technology	20
4.1 Dimensions PT4e 200-250 (electrostatic particle separator)	20
4.2 Dimensions PT4e 300-350 (electrostatic particle separator)	22
4.3 Components and connections PT4e 200-250 (electrostatic particle separator)	24
4.4 Components and connections PT4e 300-350 (electrostatic particle separator)	25
4.5 External suction module	26
4.6 Technical data	27
4.6.1 PT4e 200-250	27
4.6.2 PT4e 200-250 electrostatic particle separator	28
4.6.3 PT4e 300-350	29
4.6.4 PT4e 300-350 electrostatic particle separator	30
4.6.5 Boiler data for planning the flue gas system	33
4.6.6 Data for planning a backup power supply	34
5 Transport and storage	35
5.1 Delivery configuration	35
5.2 Temporary storage	35
5.3 Positioning	36
5.4 Dismantling for location where positioning is difficult	37

5.5	Positioning at the installation site	40
5.5.1	Remove cardboard and transport frame	40
5.5.2	Operating and maintenance areas of the equipment.....	41
6	Assembly	42
6.1	Assembly overview	42
6.2	Accessories supplied	42
6.3	Installing the boiler	43
6.3.1	Levelling the boiler	43
6.3.2	Installing the pellet suction system	43
6.3.3	Checking the return temperature control (PT4e 200-250)	45
6.3.4	Checking the return temperature control (PT4e 300-350)	46
6.3.5	Align the ash container	46
6.3.6	Installing the external suction module.....	48
6.3.7	Fit the suction hoses to the boiler	49
6.3.8	Assembly information for hose lines	50
6.4	Hydraulic connection	52
6.5	Electrical connection	54
6.5.1	Board overview	55
6.5.2	Lay the cable to the boiler controller	58
6.5.3	Connect the suction unit components.....	59
6.5.4	Connect an individual discharge systems.....	63
6.5.5	Connect multiple discharge systems with change-over units	66
6.5.6	Mains connection	74
6.5.7	Potential equalisation.....	75
6.6	Final installation steps.....	75
6.6.1	Insulate the connection line	77
6.6.2	Install the brackets for accessories.....	77
6.6.3	Affixing the identification plate	78
7	Start-up.....	79
7.1	Before commissioning / configuring the boiler	79
7.2	Initial startup.....	79
7.2.1	Permitted fuels	79
7.2.2	Non-permitted fuels.....	80
8	Decommissioning	81
8.1	Mothballing.....	81
8.2	Disassembly.....	81
8.3	Disposal	81

1 General

Thank you for choosing a quality product from Froling. The product features a state-of-the-art design and conforms to all currently applicable standards and testing guidelines.

Please read and observe the documentation provided and always keep it close to the system for reference. Observing the requirements and safety information in the documentation makes a significant contribution to safe, appropriate, environmentally friendly and economical operation of the system.

The constant further development of our products means that there may be minor differences from the pictures and content. If you discover any errors, please let us know: doku@froeling.com.

Subject to technical change.

Issuing a delivery certificate

The EC Declaration of Conformity is only valid in conjunction with a delivery certificate, which has been filled in correctly and signed as part of the commissioning process. The original document remains at the installation site. Commissioning installers or heating engineers are requested to return a copy of the delivery certificate together with the guarantee card to Froling. On commissioning by FROLING Customer Service the validity of the delivery certificate will be noted on the customer service record.

1.1 About this manual





These installation instructions contain information for the following boiler sizes of PT4e / PT4e ESP:

200, 230, 250, 300, 350;

1.2 Disposal of packaging materials

All packaging materials should be disposed of in accordance with the relevant regulations. In addition, check the regulations for correct disposal applicable in your local area.

Data under the identification system of Directive 97/129/EC:

Identification code / Material		Disposal information
	Corrugated cardboard	Paper collection
	Wood	Check the regulations for correct disposal applicable in your local area
	Low Density Polyethylene (LDPE)	Plastics collection
	Expanded polystyrene	Plastics collection

2 Safety

2.1 Hazard levels of warnings

This documentation uses warnings with the following hazard levels to indicate direct hazards and important safety instructions:

DANGER

The dangerous situation is imminent and if measures are not observed it will lead to serious injury or death. You must follow the instructions!

WARNING

The dangerous situation may occur and if measures are not observed it will lead to serious injury or death. Work with extreme care.

CAUTION

The dangerous situation may occur and if measures are not observed it will lead to minor injuries.

IMPORTANT

The dangerous situation may occur and if measures are not observed it will lead to damage to property or pollution.

2.2 Qualification of assembly staff

CAUTION



If assembly and installation are performed by unqualified persons:

Risk of personal injury and damage to property!

During assembly and installation:

- Observe the instructions and information in the manuals
- Allow only appropriately qualified personnel to work on the system

Assembly, installation, initial startup and servicing must only be carried out by qualified personnel:

- Heating technicians/building technicians
- Electrical installation technicians
- Providing customer services

The assembly staff must have read and understood the instructions in the documentation.

2.3 Personal protective equipment for assembly staff

You must ensure that staff have the protective equipment specified by accident prevention regulations!



- During transport, erection and installation:
 - wear suitable work wear
 - wear protective gloves
 - wear safety shoes (min. protection class S1P)

2.4 Residual risks for installation personnel

DANGER



Installation and commissioning of systems with electrostatic particle separators by personnel with pacemakers:

Electromagnetic fields may interfere with operation of the pacemaker when the system is switched on!



The following instruction applies to personnel with pacemakers:

- Perform installation and commissioning work only after appropriate medical assessment

3 Design Information

3.1 Overview of standards

Perform installation and commissioning of the system in accordance with the local fire and building regulations. Unless contrary to other national regulations, the latest versions of the following standards and guidelines apply:

3.1.1 General standards for heating systems

EN 303-5	Boilers for solid fuels, manually and automatically fed combustion systems, nominal heat output up to 500 kW
EN 12828	Heating systems in buildings - design of water-based heating systems
EN 13384-1	Chimneys - Thermal and fluid dynamic calculation methods Part 1: Chimneys serving one appliance
ÖNORM H 5151	Planning of central hot water heating systems with or without hot water preparation
ÖNORM M 7510-1	Guidelines for checking central heating systems Part 1: General requirements and one-off inspections
ÖNORM M 7510-4	Guidelines for checking central heating systems Part 4: Simple check for heating plants for solid fuels

3.1.2 Standards for structural and safety devices

ÖNORM H 5170	Heating installation - Requirements for construction and safety engineering, as well as fire prevention and environmental protection
ÖNORM EN ISO 20023	Solid biofuels - Safety of solid biofuel pellets - Safe handling and storage of wood pellets in residential and other small-scale applications
TRVB H 118	Technical directives for fire protection/prevention (Austria)

3.1.3 Standards for heating water

ÖNORM H 5195-1	Prevention of damage by corrosion and scale formation in closed warm water heating systems at operating temperatures up to 100°C (Austria).
VDI 2035	Prevention of damage hot water heating systems (Germany)
SWKI BT 102-01	Water quality for heating, steam, cooling and air conditioning systems (Switzerland)
UNI 8065	Technical standard regulating hot water preparation. DM 26.06.2015 (Ministerial Decree specifying the minimum requirements) Follow the instructions of this standard and any related updates. (Italy)

3.1.4 Regulations and standards for permitted fuels

1. BImSchV	First Order of the German Federal Government for the implementation of the Federal Law on Emission Protection (Ordinance on Small and Medium Combustion Plants) in the version published on 26 January 2010, BGBl. JG 2010 Part I No. 4.
EN ISO 17225-2	Solid bio-fuel - Fuel specifications and classes Part 2: Wood pellets for use in industrial and domestic systems

3.2 Installation and approval

The boiler should be operated in a closed heating system. The following standards govern the installation:

Note on standards

EN 12828 - Heating Systems in Buildings

IMPORTANT: Every heating system must be officially approved.

The appropriate supervisory authority (inspection agency) must always be informed when installing or modifying a heating system, and authorisation must be obtained from the building authorities:

Austria: report to the construction authorities of the community or magistrate

Germany: report new installations to an approved chimney sweep / the building authorities.

3.3 Installation site

Requirements for the load bearing substrate:

- Flat, clean and dry
- Non-combustible and with sufficient load-bearing capacity

Conditions at the installation site:

- Protecting the system against frost
- Sufficiently well lit
- Free of explosive atmospheres such as flammable substances, hydrogen halides, cleaning agents and consumables
- Installation at altitude higher than 2000 metres above sea level only after consultation with the manufacturer
- The system must be protected against gnawing and nesting by animals (such as rodents)
- No flammable materials in proximity to the system
- Observe national and regional regulations regarding the installation of smoke detectors and carbon monoxide detectors

IMPORTANT! Depending on the geographical location, increased cleaning effort in neighbouring areas (terrace, wellness area, etc.) may be necessary due to emissions from the system. In addition, the yield of facilities using solar energy

may be affected. To counteract the reduced performance of such equipment, we recommend cleaning on a recurrent basis or using downstream/integrated components for flue gas treatment (e.g. cyclone separators).

3.4 Chimney connection/chimney system

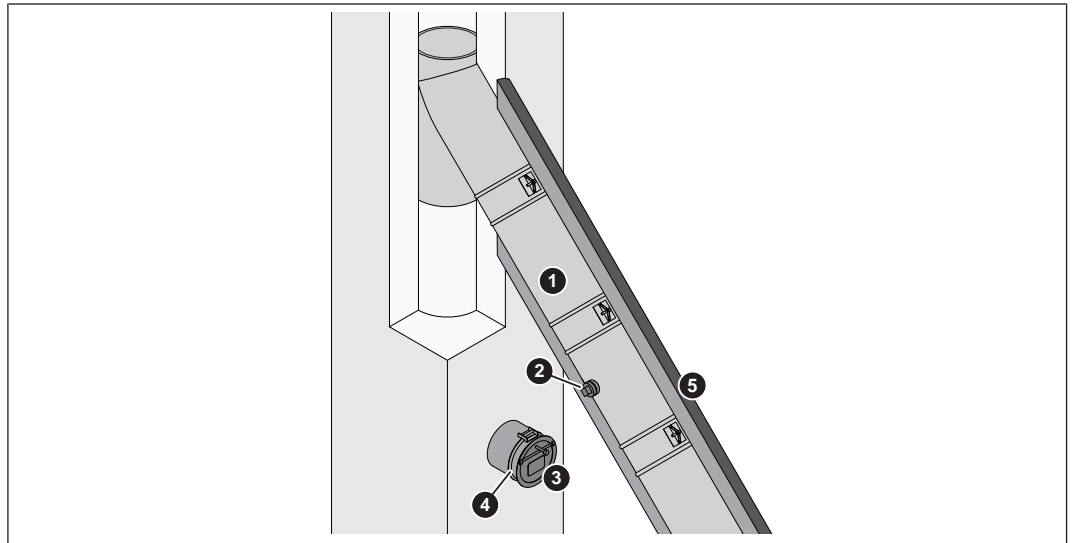

- | | |
|---|--|
| 1 | Connection line to the chimney |
| 2 | Measuring port |
| 3 | Draught limiter |
| 4 | Explosion flap (for automatic boilers) |
| 5 | Thermal insulation |

IMPORTANT! The chimney must be authorised by a smoke trap sweeper or chimney sweep.

The entire flue gas system (chimney and connection) must be laid out as per ÖNORM / DIN EN 13384-1 or ÖNORM M 7515 / DIN 4705-1.

The flue gas temperatures (for clean systems) and additional flue gas values can be found in the table in the technical data.

Local regulations and other statutory regulations are also applicable.

EN 303-5 specifies that the entire flue gas system must be designed to prevent, wherever possible, damage caused by seepage, insufficient feed pressure and condensation. Please note within the permissible operating range of the boiler flue gas temperatures lower than 160K above room temperature may occur.

3.4.1 Connection line to the chimney

Requirements for the connection line:

- this should be as short as possible and follow an upward incline to the chimney (30 - 45° recommended)
- thermally insulated

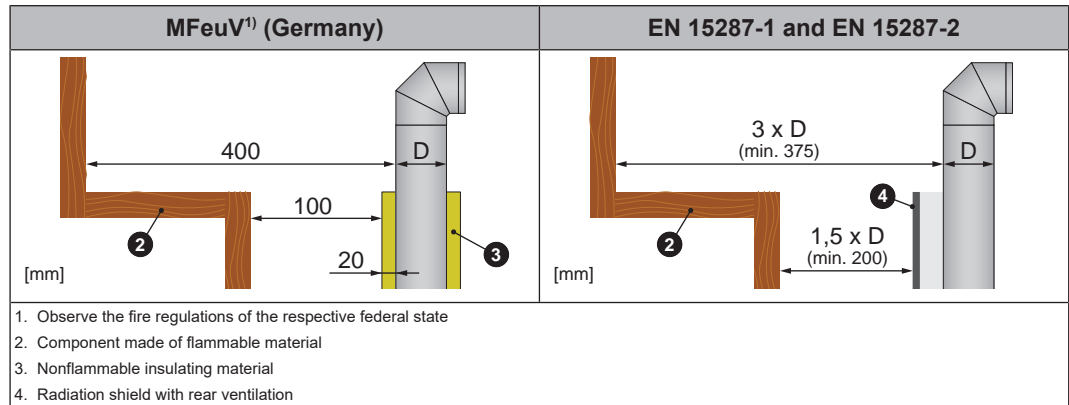

Minimum distance from flammable substances as per MFeuV¹⁾ (Germany):

- 400 mm excluding thermal insulation
- 100 mm if at least 20 mm thermal insulation is installed

Minimum distance from flammable materials as per EN 15287-1 and EN 15287-2:

- 3 x nominal diameter of connection line, but at least 375 mm (NM)
- 1.5 x nominal diameter of connection line for radiation shield with rear ventilation, but at least 200 mm (NM)

IMPORTANT! The minimum distances must be observed in accordance with the standards and guidelines applicable in the region

3.4.2 Draught limiter

We generally recommend installation of a draught limiter. If the values for the maximum permissible feed pressure stated in the section “Data for designing the flue gas system” are exceeded, a draught limiter must be installed.

Install the draught limiter directly under the discharge of the flue duct into the chimney, as at this point there is constant under-pressure which largely prevents the escape of dust from the draught limiter. If installation within the chimney is not practical, the draught limiter must be installed in the connection line to the chimney.

3.4.3 Measuring port

For emissions measurement on the system, a suitable measuring port must be installed in the connection line between the boiler and chimney system.

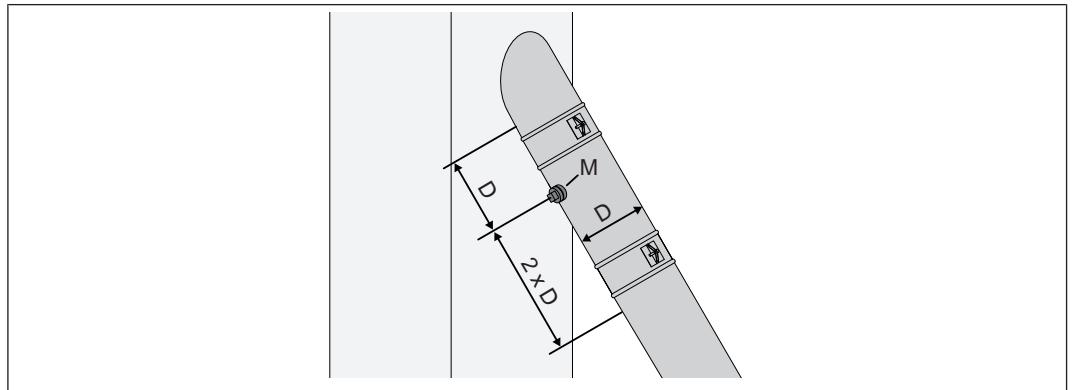

Upstream of the measuring port (M) there should be a straight run-in section with a length about twice the diameter (D) of the connection line. Downstream of the measuring port (M) there should be a straight run-out section with a length about the diameter (D) of the connection line. The measuring port must remain closed whenever the system is in operation.

The diameter of the measuring probe used by Froling customer service is 14 mm. To avoid measuring errors due to the ingress of false air, the diameter of the measuring port must not exceed 21 mm.

3.4.4 Explosion flap

A deflagration damper must be installed in the immediate vicinity of the boiler. It should be situated so that when in operation it poses no risk to persons.

3.5 Combustion air

3.5.1 General requirement

For safe operation, the boiler requires around 1.5 - 3.0 m³ of combustion air per kW nominal heat output and operating hour. The air supply can be provided by free ventilation (e.g. windows, air shaft), mechanical ventilation from outside or, if necessary, from the group of rooms.

The boiler is operated depending on the room air, whereby the combustion air is taken from the installation site.

A suitable air supply must ensure that no impermissible under-pressure greater than 4 Pa is created at the installation site. The use of safety devices (under-pressure monitoring system) may be necessary, particularly if the boiler is operated concurrently with air-suction systems (such as an extractor fan).

Local **IMPORTANT! Safety equipment and conditions for the operation of the boiler (room air-dependent / room air-independent) must be clarified with the local authority (authority, chimney sweep, ...).**

3.5.2 Room air-independent operation

The combustion air is taken from the installation site. The unpressurised flow of the required air quantity must be ensured accordingly.

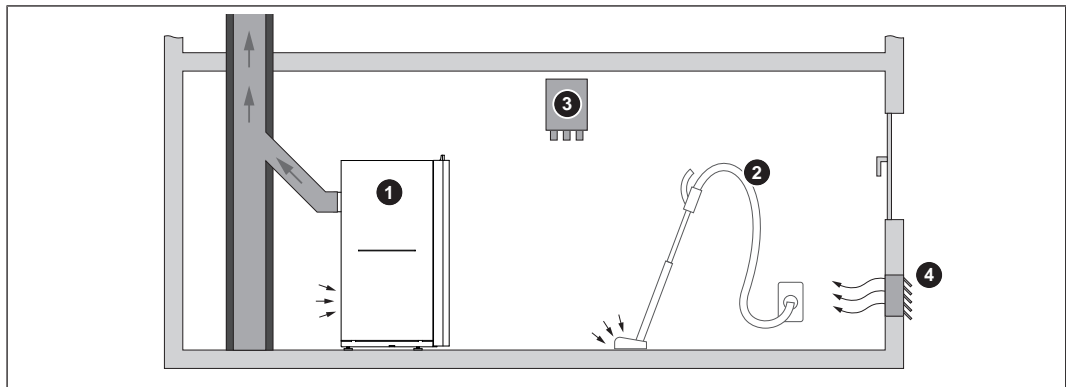

1	Boiler in room air-dependent operation
2	Air extraction system (such as centralised dust extraction system, room ventilation)
3	Under-pressure monitoring system
4	Combustion air supply from outside

The minimum cross-sectional area of the supply air opening from outside depends on the nominal heat output of the boiler.

Austria	400 cm ² net minimum cross-sectional area plus 4 cm ² for every kW of nominal heat output above 100 kW
Germany	150 cm ² net minimum cross-sectional area plus an additional 2 cm ² for every further kW of nominal heat output above 50 kW

Examples

Nominal heat output [kW]	Minimum free cross-section [cm ²]									
	10	15	20	30	50	100	150	250	350	500
Austria	400	400	400	400	400	400	600	1000	1400	2000
Germany	150	150	150	150	150	250	350	550	750	1050

Combustion air can also be supplied from other rooms if it can be proven that sufficient combustion air can flow in whilst all mechanical and natural ventilation systems are in operation. The installation site must have a minimum volume in accordance with the applicable regional standards.

Note on standards

Austria:	OIB Guideline 3 - Hygiene, health and environmental protection
Germany:	Model Firing Ordinance (MFeuV)

3.6 Domestic hot water

Unless contrary to other national regulations, the latest versions of the following standards and guidelines apply:

Austria:	ÖNORM H 5195	Switzerland:	SWKI BT 102-01
Germany:	VDI 2035	Italy:	UNI 8065

Observe the standards and also follow the recommendations below:

- Use prepared water which complies with the standards cited above for filling and make-up water
- Avoid leaks and use a closed heating system to maintain water quality during operation
- When filling with top-up water, always vent the filling hose before connecting it, in order to prevent air being drawn into the system
- Check that the heating water is clear and free of substances that can be deposited as sediments
- Check that the pH value is between 8.2 and 10.0. If the central heating water comes into contact with aluminium, the pH value must be between 8.2 and 9.0, as specified in VDI 2035
- The use of fully demineralised filling and top-up water with an electrical conductivity not exceeding 100 µS/cm is recommended by EN 14868
- After the first 6-8 weeks, check the heating water to ensure that the specified values are being adhered to
- Unless specified otherwise by regional standards and regulations, perform an annual check on the heating water

Filling and make-up water as well as heating water to VDI 2035 Sheet 1:2021-03:

Total heat output in kW	Total earth alkalis in mol/m ³ (total hardness in °dH)		
	Specific system volume in l/kW heat output ¹⁾		
	≤ 20	20 to ≤40	> 40
≤ 50 specific water content heat generator ≥ 0.3 l/kW ²⁾	none	≤ 3.0 (16.8)	< 0.05 (0.3)
≤ 50 specific water content heat generator < 0.3 l/kW ²⁾ (e.g. circulation water heater) and systems with electric heating elements	≤ 3.0 (16.8)	≤ 1.5 (8.4)	
> 50 to ≤ 200	≤ 2.0 (11.2)	≤ 1.0 (5.6)	
> 200 to ≤ 600	≤ 1.5 (8.4)	< 0.05 (0.3)	
> 600	< 0.05 (0.3)		

1. For calculating the specific system volume, the smallest individual heating capacity is to be used for systems with several heat generators.
2. In systems with several heat generators with different specific water contents, the smallest specific water content is decisive in each case.

Additional requirements for Switzerland

The filling and make-up water must be demineralised (fully purified)

- The water must not contain any ingredients that could settle and accumulate in the system
- This makes the water non-electroconductive, which prevents corrosion
- It also removes all the neutral salts such as chloride, sulphate and nitrate which can weaken corrosive materials in certain conditions

If some of the system water is lost, e.g. during repairs, the make-up water must also be demineralised. It is not enough to soften the water. The heating system must be professionally cleaned and rinsed before filling the units.

Inspection:

- After eight weeks, the pH value of the water must be between 8.2 and 10.0. If the central heating water comes into contact with aluminium, the pH value must be between 8.0 and 8.5
- Annually: values must be recorded by the owner

Advantages of heating water treated in accordance with the standards:

- Less of a drop in output due to reduced limescale build-up
- Less corrosion due to fewer aggressive substances
- Long-term cost savings thanks to improved energy efficiency

Frost protection

When operating the system with frost-protected heat transfer media, the following instructions and ÖNORM H 5195-2 must be observed:

- Antifreeze dosage according to the manufacturer's data sheet
IMPORTANT: If the medium contains too much or too little antifreeze it becomes highly corrosive
- Adding antifreeze reduces the specific heat capacity of the medium; therefore design components (pumps, pipework, etc.) accordingly
- Add frost protection only to heat transfer medium in those areas that may be affected by frost (TIP: system separation)
- Check the antifreeze dosage regularly according to the manufacturer's instructions
- Dispose of frost-protected heat transfer medium at the end of its shelf life and refill the system

3.7 Pressure maintenance systems

Pressure maintenance systems in hot-water heating systems keep the required pressure within predefined limits and balance out volume variations caused by changes in the hot-water temperature. Two main systems are used:

Compressor-controlled pressure maintenance

In compressor-controlled pressure maintenance units, a variable air cushion in the expansion tank is responsible for volume compensation and pressure maintenance. If the pressure is too low, the compressor pumps air into the tank. If the pressure is too high, air is released by means of a solenoid valve. The systems are built solely with closed-diaphragm expansion tanks to prevent the damaging introduction of oxygen into the heating water.

Pump-controlled pressure maintenance

A pump-controlled pressure maintenance unit essentially consists of a pressure-maintenance pump, relief valve and an unpressurised receiving tank. The valve releases hot water into the receiving tank if the pressure is too high. If the pressure drops below a preset value, the pump draws water from the receiving tank and feeds it back into the heating system. Pump-controlled pressure maintenance systems with **open expansion tanks** (e.g. without a diaphragm) introduce ambient oxygen via the surface of the water, exposing the connected system components to the risk of corrosion. These systems offer no oxygen removal for the purposes of corrosion control as required by VDI 2035 and **in the interests of corrosion protection should not be used.**

3.8 Return temperature control

As long as the hot water return is below the minimum return temperature, part of the hot water flow is added. This function is assumed by the function which increases the temperature inside the boiler.

3.9 Storage tank

In principle it is not necessary to use a storage tank for the system to run smoothly. However we recommend that you use the system with a storage tank, as this ensures a continuous supply of fuel in the ideal output range of the boiler.

For the correct dimensions of the storage tank and the line insulation (in accordance with ÖNORM M 7510 or guideline UZ37) please consult your installer or Fröling.

Certain subsidy guidelines prescribe compulsory requirements for the installation of storage tanks. Up-to-date information about individual subsidy guidelines can be found at www.froeling.com.

Requirements for Switzerland in accordance with LRV Appendix 3, section 523

Automatic boilers for wood pellets with a rated thermal output of more than 70 kW must be equipped with a heat accumulator of a volume of at least 25 litres per kW rated thermal output. These dimensioning specifications apply up to 500 kW nominal heat output.

Hot water tank in accordance with Commission Regulation (EU) 2015/ 1189 (Ecodesign Requirements)

It is recommended to operate the boiler with a hot water tank. The recommended storage volume = $20 \times Pr$, where Pr is the rated heat output and is indicated in kW.

3.10 Boiler ventilation



- Fit the automatic ventilating valve at the highest point on the boiler or at the ventilation connection (if present).
 - ↳ This ensures that air in the boiler is constantly expelled, thus preventing malfunctions caused by air in the boiler
- Check that the boiler ventilation is working properly
 - ↳ After installation and periodically according to manufacturer's instructions

Tip: Fit a vertical pipe as a calming section in front of the automatic ventilating valve in such a way that the ventilating valve is positioned above the water level in the boiler

Recommendation: Fit a microbubble separator in the pipes to the boiler
 ↳ Follow the manufacturer's instructions!

3.11 Installation material

When connecting the system hydraulically, ensure that the materials used (piping, seals, etc.) can withstand the maximum temperatures both during operation and in the event of a malfunction (max. 110 °C in accordance with EN 303-5).

When connecting to pipe systems with lower temperature resistance (e.g. plastic pipes for underfloor heating or district heating pipes), suitable components (e.g. contact thermostat) must be used on site to protect the materials.

4 Technology

4.1 Dimensions PT4e 200-250 (electrostatic particle separator)

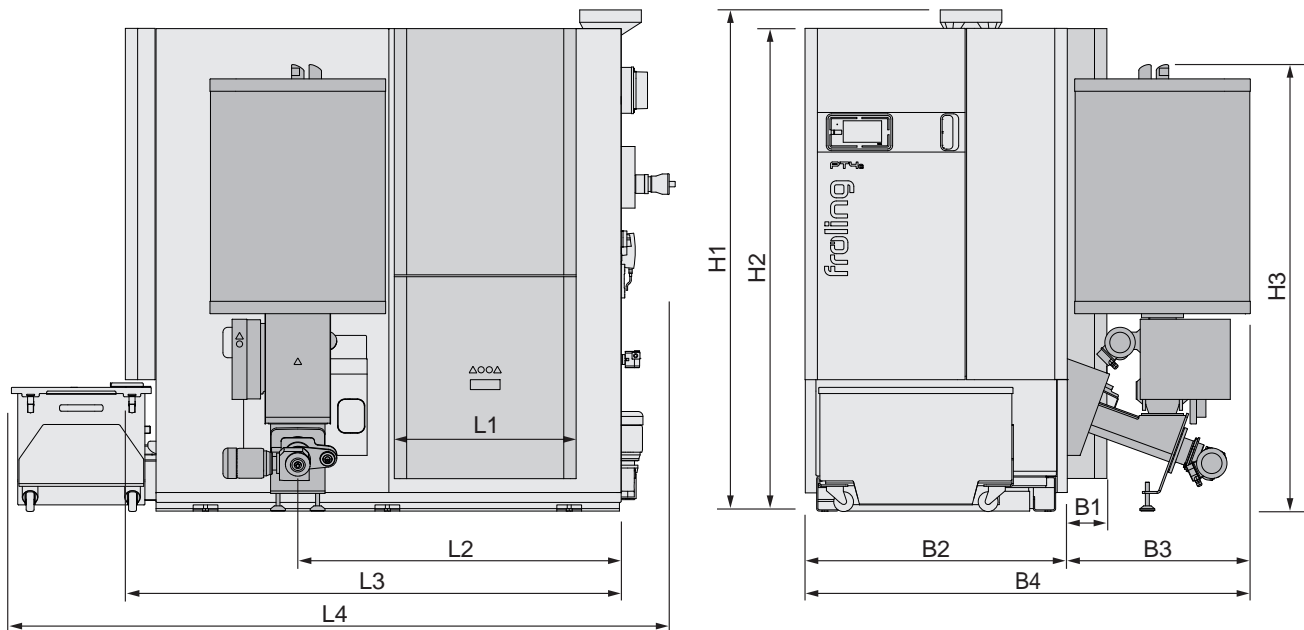

Dimension	Description		200-250
L1	Length of particle separator (optional)	mm	735
L2	Distance between stoker and back of the boiler		1310
L3	Length of boiler		2005
L4	Total length		2680
B1	Width of particle separator (optional)		160
W2	Width, boiler		1060
W3	Width of stoker unit		740
W4	Total width, including stoker unit		1800
H1	Total height incl. flue gas nozzle		2025
H2	Boiler height	1950	
H3	Height of hose line connection	1,805	

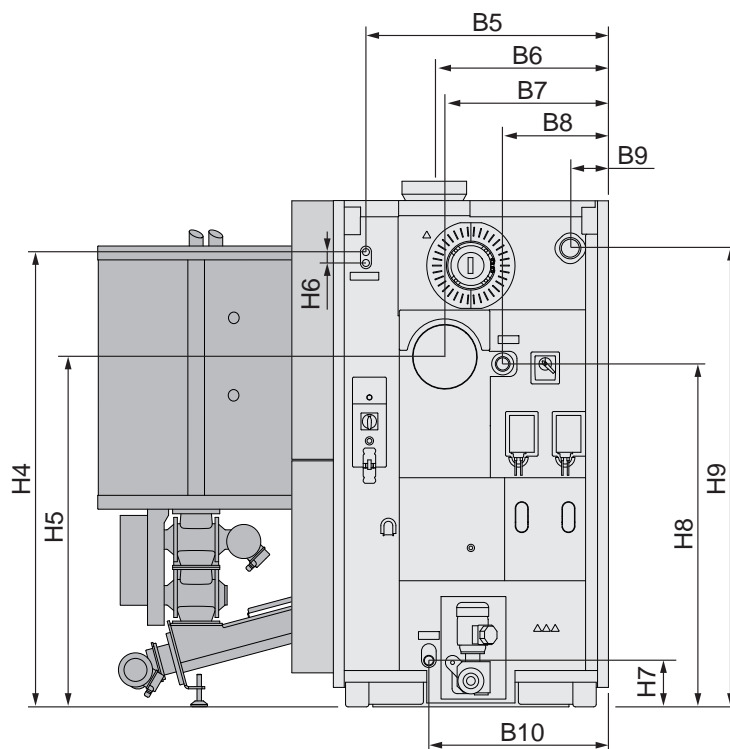

Dimension	Description		200-250
W5	Distance between safety heat exchanger connection and side of boiler	mm	935
B6	Distance between flue gas pipe connection and side of boiler		670
W7	Distance between rear flue gas pipe connection and rear of the boiler ¹⁾		630
W8	Distance between return connection and side of boiler		410
W9	Distance between flow connection and side of boiler		150
B10	Distance between drainage connection and side of boiler		690
H4	Height, safety heat exchanger connection		1755
H5	Height of rear flue gas pipe connection ¹⁾		1350
H6	Distance between safety heat exchanger connections		40
H7	Height, drainage connection		180
H8	Height of return connection	1320	
H9	Height, flow connection	1770	

1. optional

4.2 Dimensions PT4e 300-350 (electrostatic particle separator)

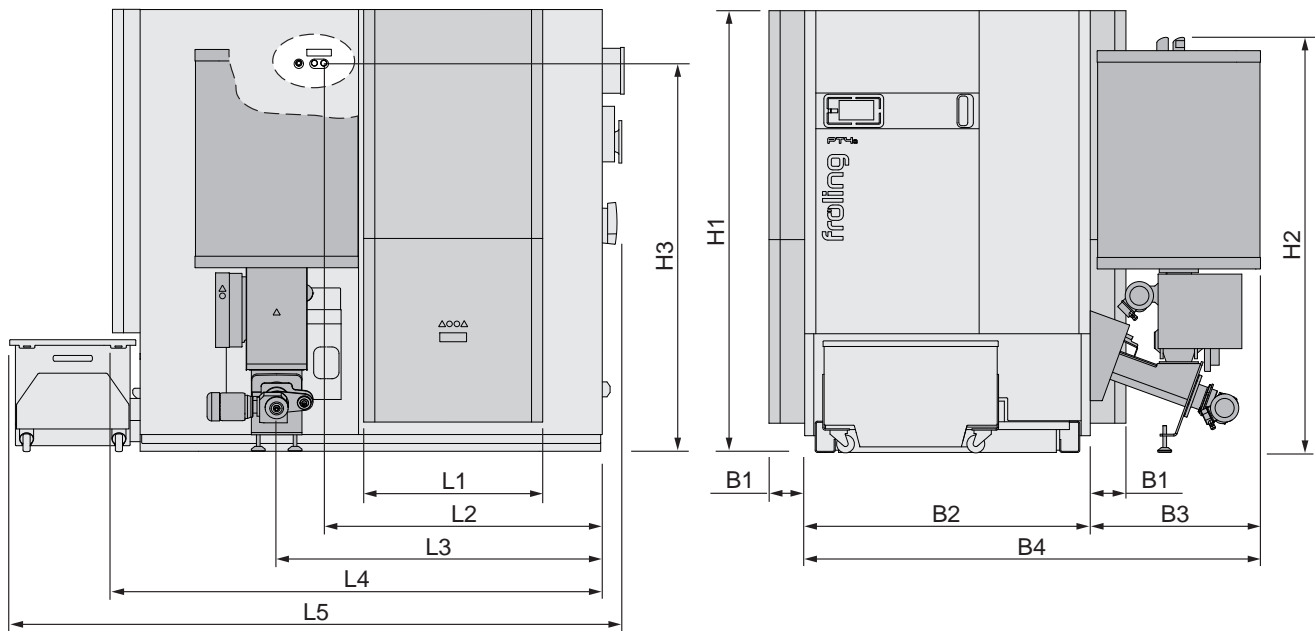

Dimension	Description		300-350
L1	Length of particle separator (optional)	mm	805
L2	Distance between the connection to the safety heat exchanger ¹⁾ and the back of the boiler		1250
L3	Distance between stoker and back of the boiler		1475
L4	Length of boiler		2195
L5	Overall length		2785
B1	Width of particle separator (optional)		160
W2	Width, boiler		1280
B3	Width of stoker unit		740
W4	Total width, including stoker unit		2020
H1	Total height incl. flue gas nozzle		1980
H2	Height of hose line connection		1,805
H3	Height, connection to safety heat exchanger ¹⁾		1740

1. Safety heat exchanger on the side facing away from the stoker

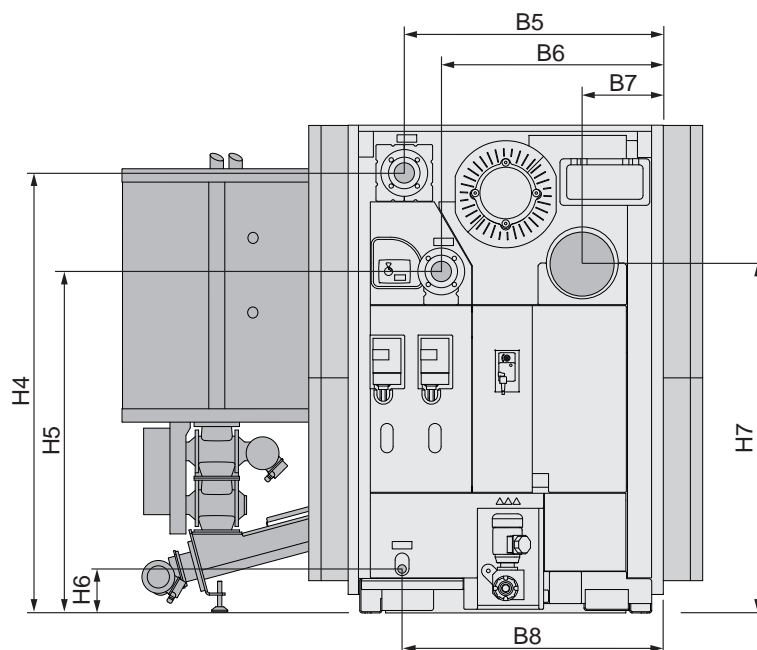

Dimension	Description		300-350
W5	Distance between flow connection and side of boiler	mm	1050
B6	Distance between return connection and side of boiler		900
W7	Distance between flue gas pipe connection and side of boiler		330
W8	Distance between drainage connection and side of boiler		1060
H4	Height of connection for flow		1790
H5	Height of return connection		1390
H6	Height, drainage connection		180
H7	Height, flue pipe connection		1420

4.3 Components and connections PT4e 200-250 (electrostatic particle separator)

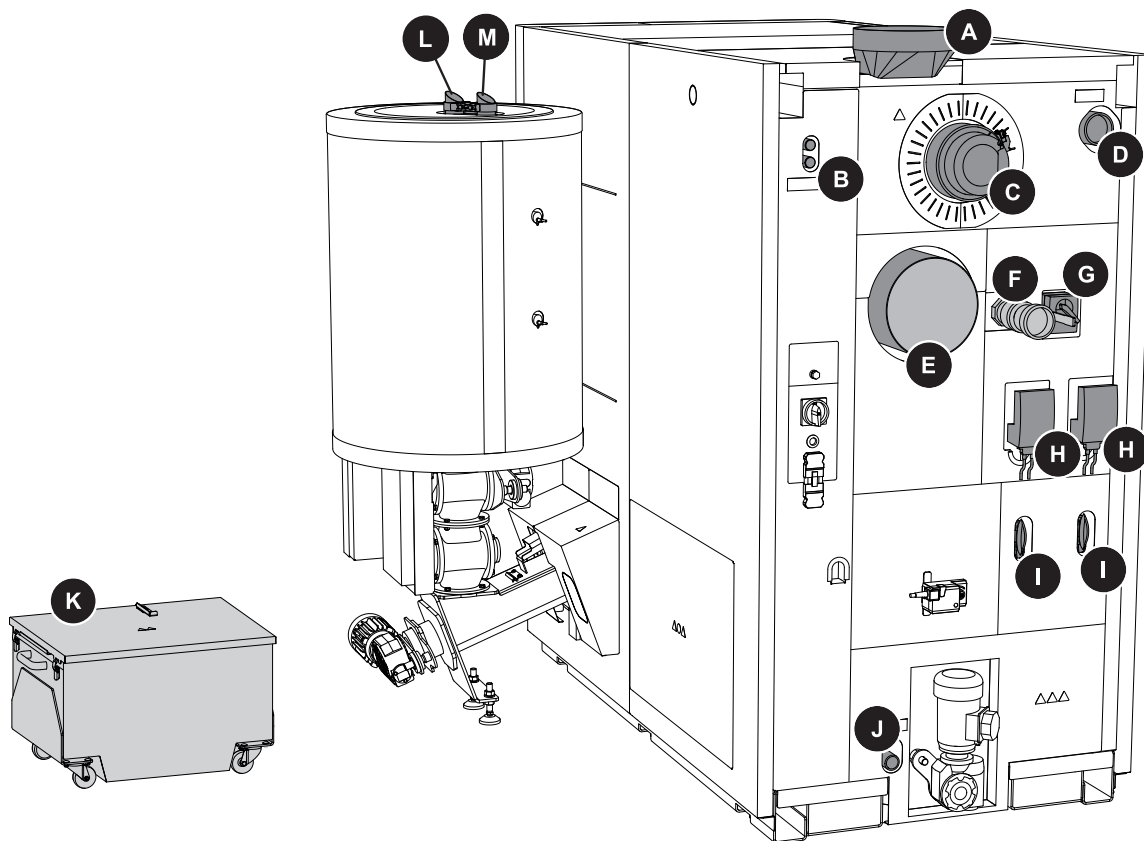

Item	Description	200-250
A	Flue gas pipe connection	249 mm
B	Safety heat exchanger	1/2"
C	Induced draught fan	-
D	Boiler flow	2 1/2"
E	Rear flue gas pipe connection (optional)	249 mm
F	Boiler return	2 1/2"
G	Mixing valve for the return temperature control	-
H	Pump for the return temperature control	-
I	Line regulating valve	-
J	Drainage	1"
K	Ash container	160 Litres
L	Suction hose connection (PELLETS sticker)	50 mm
M	Return-air line connection	50 mm

4.4 Components and connections PT4e 300-350 (electrostatic particle separator)

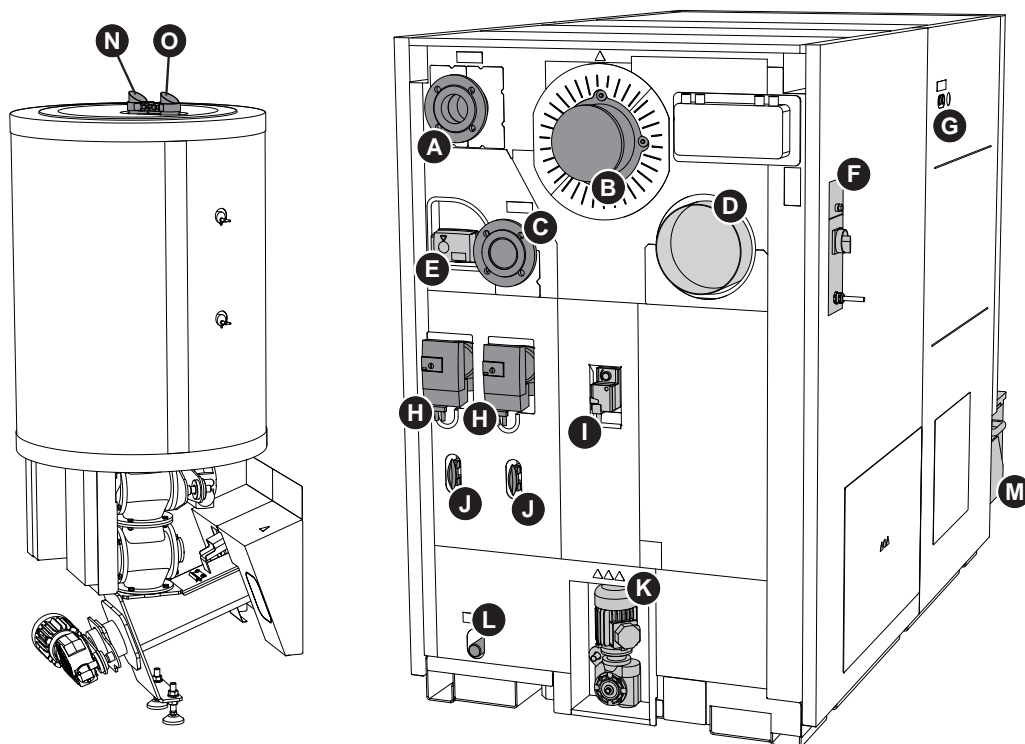

Item	Description	300-350
A	Boiler flow	DN 80 / PN 6
B	Induced draught fan	-
C	Boiler return	DN 80 / PN 6
D	Flue gas pipe connection	249 mm
E	Mixing valve for the return temperature control	-
F	Main switch and safety temperature limiter STL	-
G	Safety heat exchanger	1/2"
H	Pump for the return temperature control	-
I	Primary air actuator for flue gas recirculation	-
J	Line regulating valve	-
K	Drive for ash removal	-
L	Drainage	1"
M	Ash container	160 Litres
N	Suction hose connection (PELLETS sticker)	50 mm
O	Return-air line connection	50 mm

4.5 External suction module

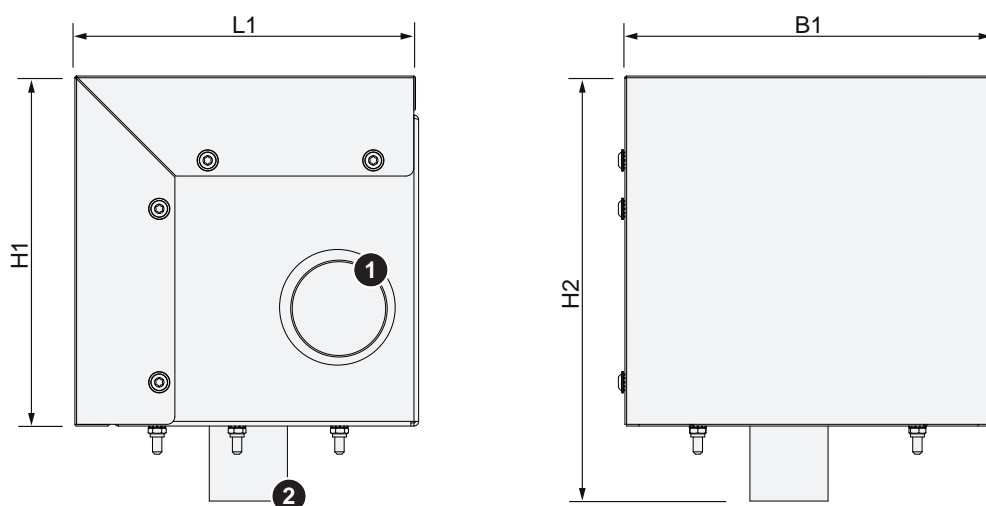

Dimension	Description	Unit	Size 1	Size 2
L1	Length of suction module	mm	220	265
B1	Width of suction module		235	290
H1	Height of suction module		225	235
H2	Total height incl. hose connection		275	285
1	Return air line connection (line to suction point)	mm	50	
2	Connection return air line (line from boiler)		50	

4.6 Technical data

4.6.1 PT4e 200-250

Description		PT4e 200-250		
		200	230	250
Nominal output range	kW	59.0 – 199.0	69.0 – 230.0	75.0 – 250.0
Boiler efficiency (NCV) at nominal load/partial load	%	94.2 / 93.6	93.8 / 93.6	93.5 / 93.6
Electrical connection		400V / 50Hz / fused C16A		
Weight of boiler (including stoker, without water)	kg	2500		
Boiler capacity (water)	l	438		
Capacity of cyclone container		205 ¹⁾		
Available feed height of the pump ²⁾ (at $\Delta T = 20K$)	mbar	446	340	273
Max. permitted operating temperature	°C	90		
Permitted operating pressure	bar	4		
Boiler class as per EN 303-5: 2012		5		
Airborne sound level	dB(A)	<70		
Permitted fuel as per EN ISO 17225 ³⁾		Part 2: Wood pellets class A1 / D06		
Test book number		PB 145	PB 178	PB 146
1. equivalent to approx. 110 kg of pellets with a bulk weight of 650 kg/m ³ 2. Pump output less water resistance in the boiler 3. Detailed information on the fuel can be found in the operating instructions in the section entitled "Permitted fuels"				

Product data in accordance with the regulations (EU) 2015/1187 and 2015/1189

Description		PT4e 200-250		
		200	230	250
Heating up mode		automatic		
Condensing boiler		No		
Solid fuel boiler for combined heat and power		No		
Combined heating system		No		
Storage tank volume		➔ "Storage tank" [► 19]		
Preferred fuel		Compressed wood in the form of pellets		
Useful heat delivered at rated heat output (P_n)	kW	199	230	250
Useful heat delivered at 30% of rated heat output (P_p)		59	69	75
Fuel efficiency at rated heat output (η_n)	%	87.0	86.6	86.3
Fuel efficiency at 30% of rated heat output (η_p)		86.4	86.4	86.4
Auxiliary current consumption at rated heat output ($e_{l,max}$)	kW	0.120	0.146	0.162
Auxiliary current consumption at 30% of rated heat output (η_p)		0.055	0.055	0.055
Auxiliary current consumption in standby mode (P_{SB})		0.013	0.013	0.013
Temperature controller used		Lambdatronic H 3200		
Class of the temperature controller		II	II	II
Contribution of the temperature controller to the energy efficiency index of a combined system	%	2	2	2

Description		PT4e 200-250		
		200	230	250
Heating space annual rate of use η_s	%	83	83	83
Annual space heating emissions of dust (PM) ¹⁾	mg/m ³	17	17	17
Annual space heating emissions of gaseous organic compounds (GOC) ¹⁾	mg/m ³	< 3	< 3	< 3
Annual space heating emissions of carbon monoxide (CO) ¹⁾	mg/m ³	24	24	23
Annual space heating emissions of nitrogen oxides (NOx) ¹⁾	mg/m ³	115	115	115

1. Specified emission values refer to dry flue gas with an oxygen content of 10 % and under standard conditions at 0°C and 1013 millibars.
The evaluation values reported are rounded to the nearest whole number.
Values labelled with "<" represent the relative detection limit of the measuring methods or measuring device configurations used.

4.6.2 PT4e 200-250 electrostatic particle separator

Description		PT4e 200–250 electrostatic particle separator		
		200	230	250
Nominal output range	kW	59.0 – 199.0	69.0 – 230.0	75.0 – 250.0
Boiler efficiency (NCV) at nominal load/partial load	%	94.1 / 93.6	93.8 / 93.6	93.6 / 93.6
Electrical connection		400V / 50Hz / fused C16A		
Weight of boiler (including stoker, without water)	kg	2500		
Boiler capacity (water)	l	438		
Capacity of cyclone container		205 ¹⁾		
Available feed height of the pump ²⁾ (at $\Delta T = 20K$)	mbar	446	340	273
Max. permitted operating temperature	°C	90		
Permitted operating pressure	bar	4		
Boiler class as per EN 303-5: 2012		5		
Airborne sound level	dB(A)	<70		
Permitted fuel as per EN ISO 17225 ³⁾		Part 2: Wood pellets class A1 / D06		
Test book number		PB 176	PB 179	PB 177

1. equivalent to approx. 110 kg of pellets with a bulk weight of 650 kg/m³
2. Pump output less water resistance in the boiler
3. Detailed information on the fuel can be found in the operating instructions in the section entitled "Permitted fuels"

Product data in accordance with the regulations (EU) 2015/1187 and 2015/1189

Description		PT4e 200-250 electrostatic particle separator		
		200	230	250
Heating up mode		automatic		
Condensing boiler		No		
Solid fuel boiler for combined heat and power		No		
Combined heating system		No		
Storage tank volume		➔ "Storage tank" ► 19]		
Preferred fuel		Compressed wood in the form of pellets		

Description		PT4e 200-250 electrostatic particle separator		
		200	230	250
Useful heat delivered at rated heat output (P_n)	kW	199	230	250
Useful heat delivered at 30% of rated heat output (P_p)		59.0	69.0	75.0
Fuel efficiency at rated heat output (η_n)	%	87.0	86.6	86.4
Fuel efficiency at 30% of rated heat output (η_p)		86.4	86.4	86.4
Auxiliary current consumption at rated heat output ($e_{l,max}$)	kW	0.218	0.270	0.303
Auxiliary current consumption at 30% of rated heat output (η_p)		0.055	0.055	0.055
Auxiliary current consumption in standby mode (P_{SB})		0.029	0.029	0.029
Temperature controller used	Lambdatronic H 3200			
Class of the temperature controller		II	II	II
Contribution of the temperature controller to the energy efficiency index of a combined system	%	2	2	2
Heating space annual rate of use η_s	%	83	83	83
Annual space heating emissions of dust (PM) ¹⁾	mg/m ³	15	16	16
Annual space heating emissions of gaseous organic compounds (GOC) ¹⁾	mg/m ³	< 3	< 4	< 3
Annual space heating emissions of carbon monoxide (CO) ¹⁾	mg/m ³	23	23	23
Annual space heating emissions of nitrogen oxides (NOx) ¹⁾	mg/m ³	116	116	116

1. Specified emission values refer to dry flue gas with an oxygen content of 10 % and under standard conditions at 0°C and 1013 millibars. The evaluation values reported are rounded to the nearest whole number. Values labelled with "<" represent the relative detection limit of the measuring methods or measuring device configurations used.

4.6.3 PT4e 300-350

Description		PT4e 300-350	
		300	350
Nominal output range	kW	90 – 300	103.2 - 344
Boiler efficiency (NCV) at nominal load/partial load	%	93.9 / 93.8	94.3 / 93.9
Electrical connection	400V / 50Hz / fused C25A		
Weight of boiler (including stoker, without water)	kg	3000	
Boiler capacity (water)	l	783	
Capacity of cyclone container		205 ¹⁾	
Available feed height of the pump ²⁾ (at $\Delta T = 20K$)	mbar	543	344
Max. permitted operating temperature	°C	90	
Permitted operating pressure	bar	4	
Boiler class as per EN 303-5: 2012	5		
Airborne sound level	dB(A)	<70	
Permitted fuel as per EN ISO 17225 ³⁾	Part 2: Wood pellets class A1 / D06		
Test book number		PB 225	PB 226

1. equivalent to approx. 110 kg of pellets with a bulk density of 650 kg/m³
2. Pump output less water resistance in the boiler

Description	PT4e 300-350	
	300	350
3. Detailed information on the fuel can be found in the operating instructions in the section entitled "Permitted fuels"		

Product data in accordance with the regulations (EU) 2015/1187 and 2015/1189

Description		PT4e 300-350	
		300	350
Heating up mode		automatic	
Condensing boiler		No	
Solid fuel boiler for combined heat and power		No	
Combined heating system		No	
Storage tank volume		➔ "Storage tank" [▶ 19]	
Preferred fuel		Compressed wood in the form of pellets	
Useful heat delivered at rated heat output (P_n)	kW	300	344
Useful heat delivered at 30% of rated heat output (P_p)		90	103.2
Fuel efficiency at rated heat output (η_n)	%	84.3	84.6
Fuel efficiency at 30% of rated heat output (η_p)		84.0	84.3
Auxiliary current consumption at rated heat output ($e_{l_{max}}$)	kW	0.224	0.286
Auxiliary current consumption at 30% of rated heat output (η_p)		0.078	0.100
Auxiliary current consumption in standby mode (P_{SB})		0.013	0.013
Temperature controller used		Lambdatronic H 3200	
Class of the temperature controller		II	II
Contribution of the temperature controller to the energy efficiency index of a combined system	%	2	2
Heating space annual rate of use η_s	%	81	81
Annual space heating emissions of dust (PM) ¹⁾	mg/m ³	14	11
Annual space heating emissions of gaseous organic compounds (GOC) ¹⁾	mg/m ³	< 3	< 3
Annual space heating emissions of carbon monoxide (CO) ¹⁾	mg/m ³	15	7
Annual space heating emissions of nitrogen oxides (NOx) ¹⁾	mg/m ³	14	11
1. Specified emission values refer to dry flue gas with an oxygen content of 10 % and under standard conditions at 0°C and 1013 millibars. The evaluation values reported are rounded to the nearest whole number. Values labelled with "<" represent the relative detection limit of the measuring methods or measuring device configurations used.			

4.6.4 PT4e 300-350 electrostatic particle separator

Description		PT4e 300–350 electrostatic particle separator	
		300	350
Nominal output range	kW	90 – 300	103.2 - 344
Boiler efficiency (NCV) at nominal load/partial load	%	93.9 / 93.8	94.3 / 93.9

Description		PT4e 300–350 electrostatic particle separator	
		300	350
Electrical connection		400V / 50Hz / fused C25A	
Weight of boiler (including stoker, without water)	kg	3000	
Boiler capacity (water)	l	783	
Capacity of cyclone container		205 ¹⁾	
Available feed height of the pump ²⁾ (at $\Delta T = 20K$)	mbar	543	344
Max. permitted operating temperature	°C	90	
Permitted operating pressure	bar	4	
Boiler class as per EN 303-5: 2012		5	
Airborne sound level	dB(A)	<70	
Permitted fuel as per EN ISO 17225 ³⁾		Part 2: Wood pellets class A1 / D06	
Test book number		PB 227	PB 228
<p>1. equivalent to approx. 110 kg of pellets with a bulk density of 650 kg/m³</p> <p>2. Pump output less water resistance in the boiler</p> <p>3. Detailed information on the fuel can be found in the operating instructions in the section entitled "Permitted fuels"</p>			

Product data in accordance with the regulations (EU) 2015/1187 and 2015/1189

Description		PT4e 300-350 electrostatic particle separator	
		300	350
Heating up mode		automatic	
Condensing boiler		No	
Solid fuel boiler for combined heat and power		No	
Combined heating system		No	
Storage tank volume		↪ "Storage tank" [▶ 19]	
Preferred fuel		Compressed wood in the form of pellets	
Useful heat delivered at rated heat output (P_n)	kW	300	350
Useful heat delivered at 30% of rated heat output (P_p)		90.0	105
Fuel efficiency at rated heat output (η_n)	%	94.0	94.4
Fuel efficiency at 30% of rated heat output (η_p)		93.8	93.9
Auxiliary current consumption at rated heat output ($e_{I_{max}}$)	kW	0.341	0.379
Auxiliary current consumption at 30% of rated heat output (η_p)		0.078	0.100
Auxiliary current consumption in standby mode (P_{SB})		0.028	0.026
Temperature controller used		Lambdatronic H 3200	
Class of the temperature controller		II	II
Contribution of the temperature controller to the energy efficiency index of a combined system	%	2	2
Heating space annual rate of use η_s	%	86.6	86.9
Annual space heating emissions of dust (PM) ¹⁾	mg/m ³	13	10
Annual space heating emissions of gaseous organic compounds (GOC) ¹⁾	mg/m ³	< 3	< 3
Annual space heating emissions of carbon monoxide (CO) ¹⁾	mg/m ³	15	8

Description		PT4e 300-350 electrostatic particle separator	
		300	350
Annual space heating emissions of nitrogen oxides (NO _x) ¹⁾	mg/m ³	123	129
<small>1. Specified emission values refer to dry flue gas with an oxygen content of 10 % and under standard conditions at 0°C and 1013 millibars. The evaluation values reported are rounded to the nearest whole number. Values labelled with "<" represent the relative detection limit of the measuring methods or measuring device configurations used.</small>			

4.6.5 Boiler data for planning the flue gas system

The flue gas performance values listed below should be used for calculation of the fluid dynamics for flue gas systems as specified in the EN 13384 series of standards. The flue gas performance values for the respective outputs are applicable under typical operating conditions when using fuels consistent with the fuel class specified in EN ISO 17225.

Designation		PT4e (ESP)		
		200	230	250
Flue gas temperature at rated heat output T_{WN} / at the lowest output T_{Wmin}	°C	130 / 85	135 / 85	140 / 85
Volumetric concentration of CO ₂ in the dry flue gas $\sigma(\text{CO}_2)$ at rated heat output	%	12.3	12.3	12.8
Flue gas mass flow at rated heat output \dot{m}_N / at the lowest output \dot{m}_{min}	kg/h	425 / 133	493 / 155	517 / 162
	kg/s	0.118 / 0.037	0.137 / 0.043	0.144 / 0.045
Feed pressure P_{WN} required at the rated heat output / P_{Wmin} required at the lowest output	Pa	5 / 2		
Maximum permissible feed pressure P_{Wmax}	Pa	30		
Feed pressure P_{WO} (blower fan delivery pressure) available at the appliance	Pa	-		
Flue spigot diameter D	mm	249		
Data to be used when for operation independent of the room air				
Supply air connection diameter	mm	-		
Maximum permissible pressure drop P_{Bmax} in the supply air duct	Pa	-		
Combustion air volume at rated heat output	m ³ /h	-	-	-

Designation		PT4e (ESP)	
		300	350
Flue gas temperature at rated heat output T_{WN} / at the lowest output T_{Wmin}	°C	130 / 85	135 / 85
Volumetric concentration of CO ₂ in the dry flue gas $\sigma(\text{CO}_2)$ at rated heat output	%	12.8	13.3
Flue gas mass flow at rated heat output \dot{m}_N / at the lowest output \dot{m}_{min}	kg/h	620 / 194	724 / 227
	kg/s	0.172 / 0.054	0.201 / 0.063
Feed pressure P_{WN} required at the rated heat output / P_{Wmin} required at the lowest output	Pa	5 / 2	
Maximum permissible feed pressure P_{Wmax}	Pa	30	
Feed pressure P_{WO} (blower fan delivery pressure) available at the appliance	Pa	-	
Flue spigot diameter D	mm	249	
Data to be used when for operation independent of the room air			
Supply air connection diameter	mm	-	
Maximum permissible pressure drop P_{Bmax} in the supply air duct	Pa	-	
Combustion air volume at rated heat output	m ³ /h	-	-

4.6.6 Data for planning a backup power supply

At output 200-250 kW:

Description		Value
Continuous output (three phase)	VA	6375
Nominal voltage	VAC	400 ± 6%
Frequency	Hz	50 ± 2%

At output 300-350 kW:

Description		Value
Continuous output (three phase)	VA	9960
Nominal voltage	VAC	400 ± 6%
Frequency	Hz	50 ± 2%

5 Transport and storage

5.1 Delivery configuration

The boiler and associated components are delivered on a pallet.

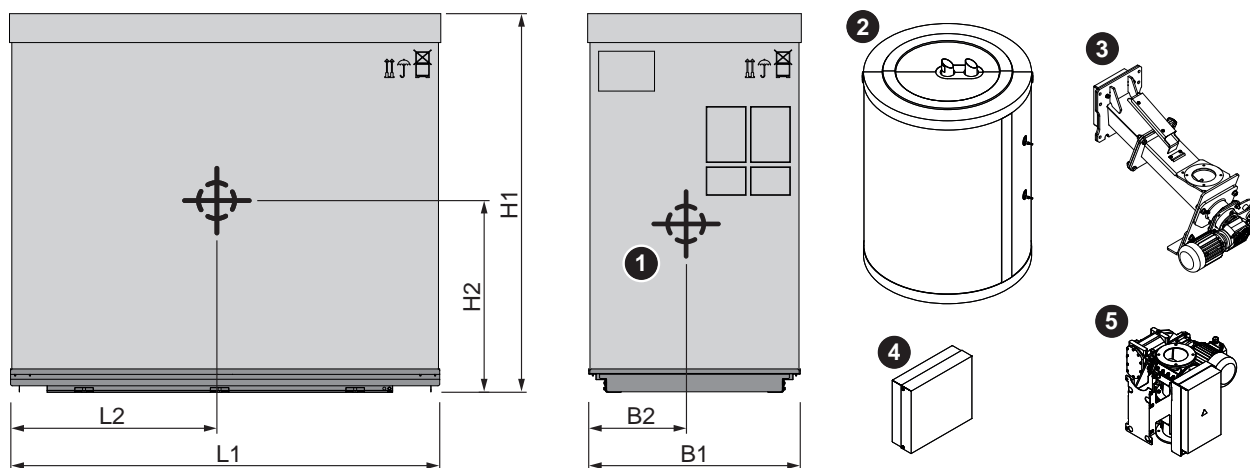

Item	Description	Unit	200-250	300-350
L1	Length	mm	2340	2450
B1	Width		1160	1370
H1	Height		2055	2005
Centre of gravity:				
L2	Length	mm	1205	1260
B2	Width		590	690
H2	Height		890	910
Weight of the components:				
1	Boiler	kg	2320	2825
2	Cyclone container		35	
3	Stoker unit		55	
4	Distributor box		10	
5	Rotary valve unit		50	

5.2 Temporary storage

If the system is to be assembled at a later stage:

- Store components at a protected location, which is dry and free from dust
 - ↳ Damp conditions and frost can damage components, particularly electric ones!

5.3 Positioning

IMPORTANT



Damage to components if handled incorrectly

- Follow the transport instructions on the packaging
- Transport components with care to avoid damage
- Protect the packaging against damp conditions
- Pay attention to the pallet's centre of gravity when lifting

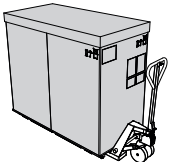

- Position a forklift or similar lifting device at the boiler base and bring in the components
 - ↳ **200-250 kW:** Min. fork length 1,500 mm, min. load capacity 2,500 kg
 - ↳ **300-350 kW:** Min. fork length 1,500 mm, min. load capacity 3,000 kg

If you need to dismantle the boiler to bring it in:

- Remove cardboard and transport frame
 - ↳ "Remove cardboard and transport frame" [▶ 40]
- Dismantle the components of the boiler until it can be brought in
 - ↳ "Dismantling for location where positioning is difficult" [▶ 37]

Positioning using a crane:

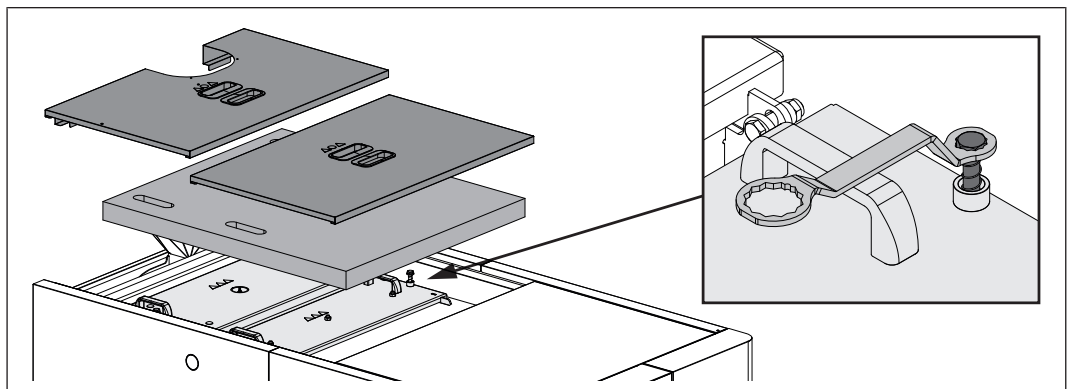

- Remove the insulating cover and thermal insulation
 - ↳ 200-250 kW: two insulating covers
 - ↳ 300-350 kW: three insulating covers
- Loosen the screw connection on the front heat exchanger cover and open the cover
 - ↳ Use the spanner provided

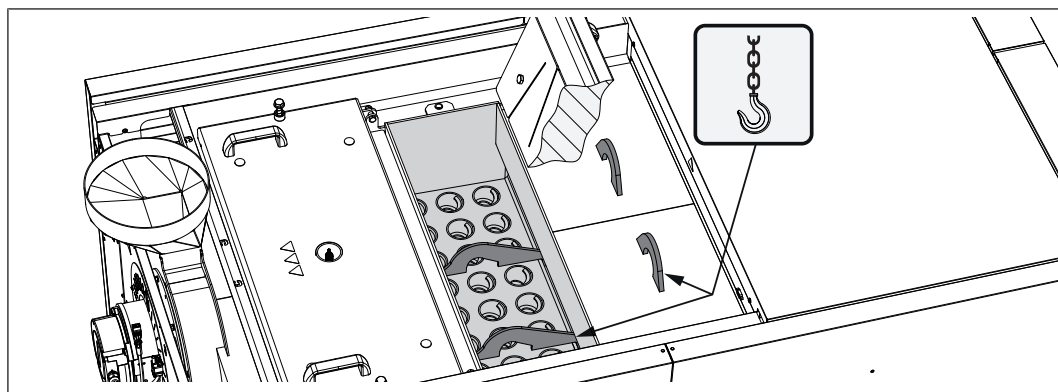

- Hang the crane hook on the two eye bolts in the flue gas collection chamber and on the heat exchanger and bring in the boiler

↪ It is only possible to transport the boiler straight in by using all four eye bolts

5.4 Dismantling for location where positioning is difficult

If there is not enough room to bring in the pre-assembled boiler, certain components can be dismantled.

IMPORTANT! Only take those steps absolutely necessary to bring in the boiler.

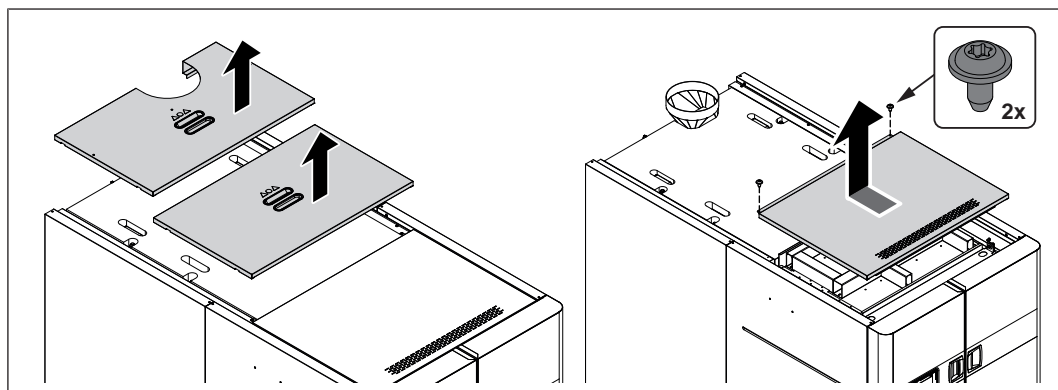

- Remove the insulated cover above the heat exchanger

↪ 200-250 kW: two insulating covers

↪ 300-350 kW: three insulating covers

- Undo both screws and remove controller cover

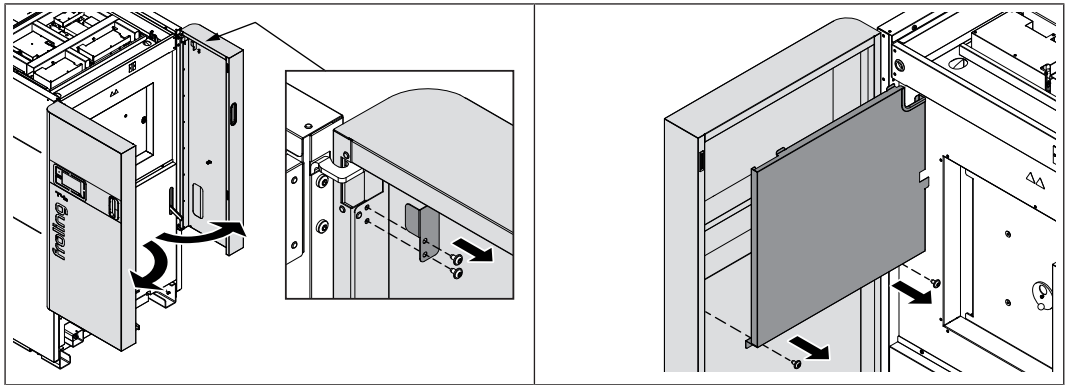

- Open the insulated doors
- Remove the small cover plate on the hinge of the right insulated door
- Remove the control cover on the left insulated door
- Unplug both connectors on the control
- Remove both insulated doors

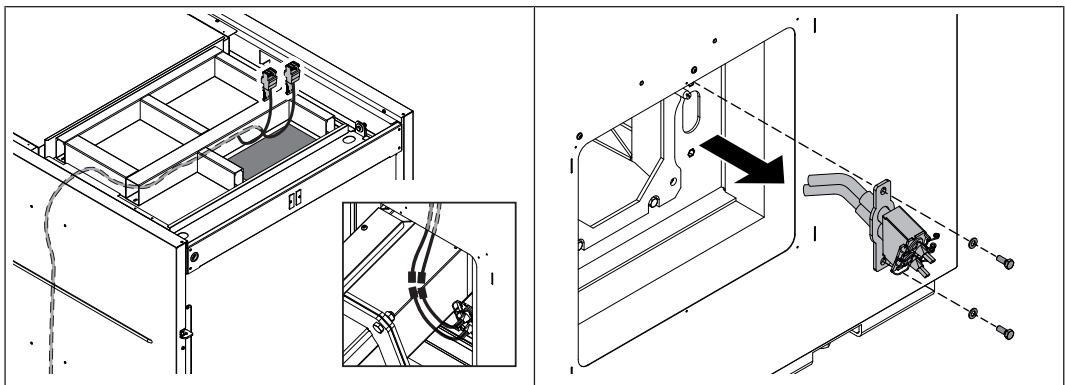

- Unplug the connector for the ignition and the stoker drive from the wood chip module
- Pull the cable out of the cable duct in the controller box
 - ↳ Cables can remain in the cable duct on the side panel
- Remove the ignition unit including glow igniter beside stoker

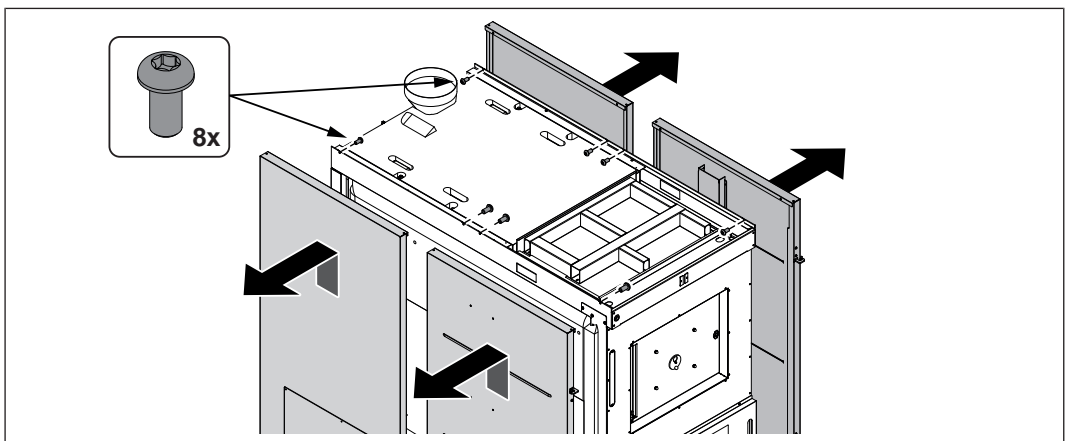

- Undo the screws and remove the side panels

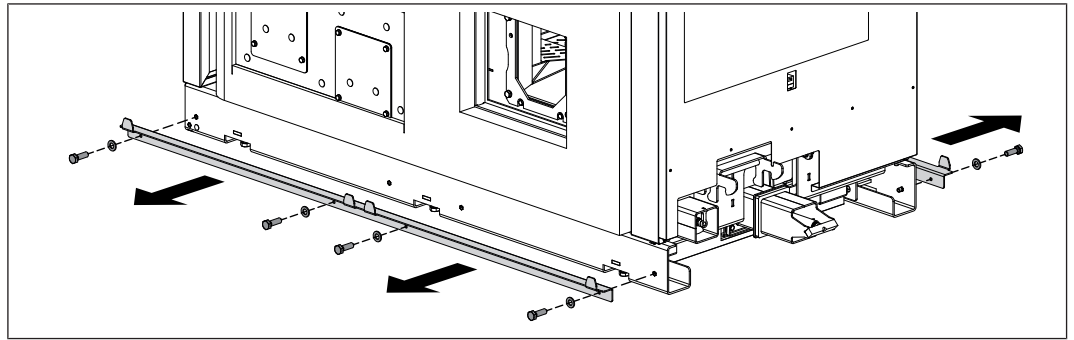

□ Undo the screws and remove both of the lower frames

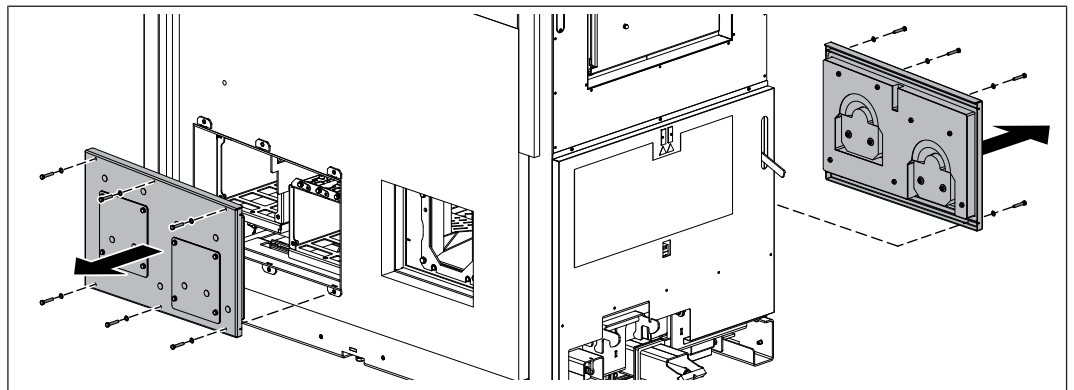

□ Remove maintenance covers from both sides of the boiler

Positioning dimensions after dismantling:

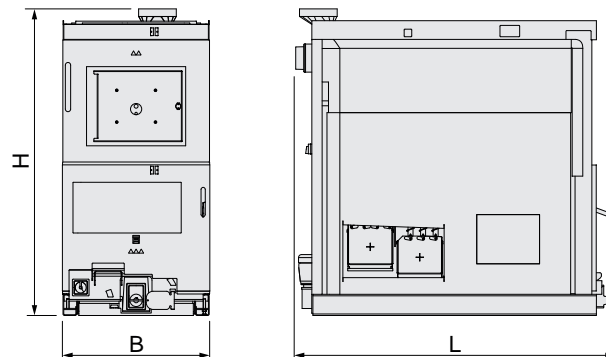

Item	Unit	200-250	300-350
L	mm	2210	2340
B		980	1195
H		2030	1980

IMPORTANT! Assemble all components in reverse order.

Connect the glow igniter plug on the wood chip module to the “ELECTRICAL IGNITION” position and the stoker drive to the “STOKER SCREW” position.

5.5 Positioning at the installation site

5.5.1 Remove cardboard and transport frame

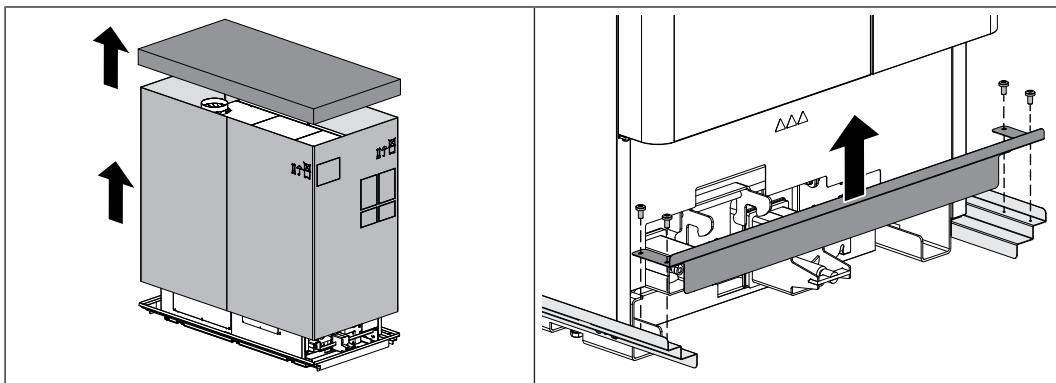

- Remove strapping and lift off the cardboard
- Remove transport frame from front and back

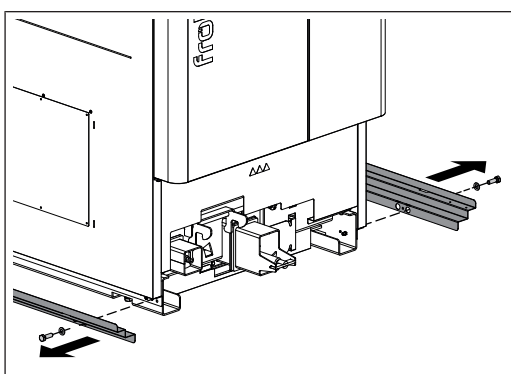

- Remove the sides of the transport frame from the boiler base

5.5.2 Operating and maintenance areas of the equipment

- The system should generally be set up so that it is accessible from all sides to allow quick and easy maintenance!
- Regional regulations regarding necessary maintenance areas for inspecting the chimney should be observed in addition to the specified distances!
- Observe the applicable standards and regulations when setting up the system!
- Comply with additional standards for noise protection!
(ÖNORM H 5190 - Noise protection measures)

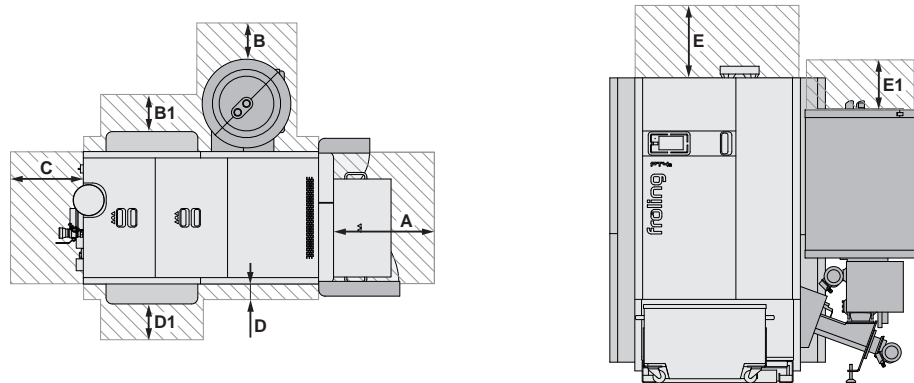

	PT4e 200-250	PT4e 300-350
A	900 mm	
W	300 mm	
B1	300 mm	
C	500 mm	
D	150 mm	
D1	300 mm	
E	500 mm ¹⁾	
E1	300 mm	

1. Maintenance area to expand the WOS springs upwards

6 Assembly

6.1 Assembly overview

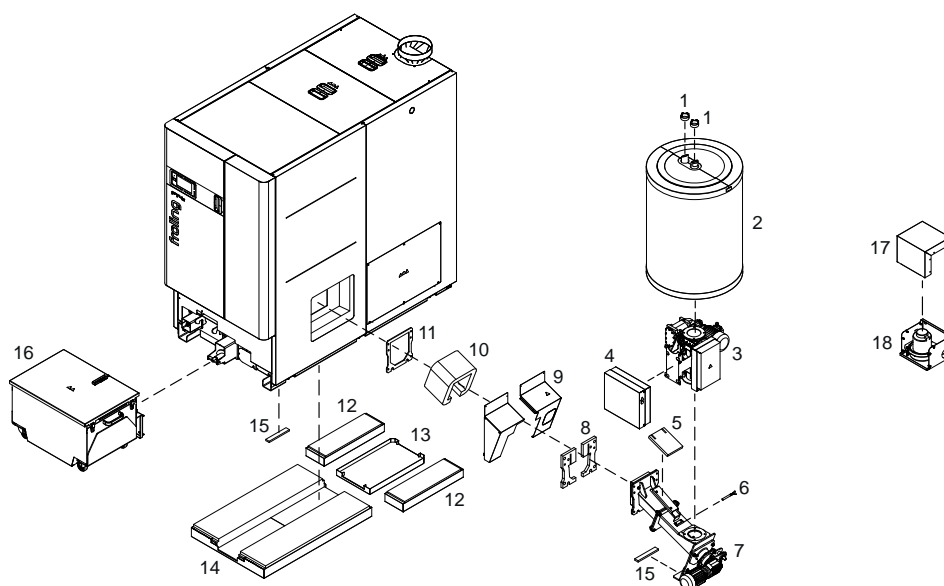

1	Hose clamp	10	Stoker duct thermal insulation
2	Cyclone container	11	Stoker unit seal
3	Rotary valve unit	12	Side back floor insulation
4	Control cabinet	13	Centre back floor insulation
5	Stoker duct insulating panel	14	Front floor insulation
6	temperature sensor	15	Boiler documents (8 items)
7	Stoker unit	16	Ash container
8	Stoker duct flange insulating panels	17	Suction module cover hood
9	Stoker duct cover	18	Suction module

6.2 Accessories supplied

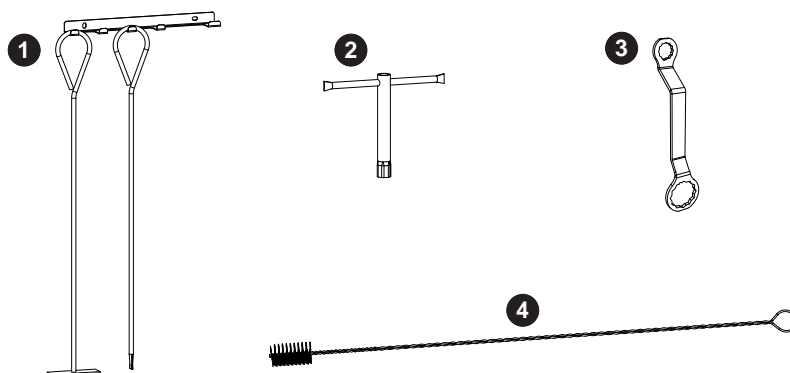

1	Furnace tool with bracket	3	Key for door mountings and WOS cover
2	Socket wrench AF 13	4	Cleaning brush 24 x 50 x 1200

6.3 Installing the boiler

6.3.1 Levelling the boiler

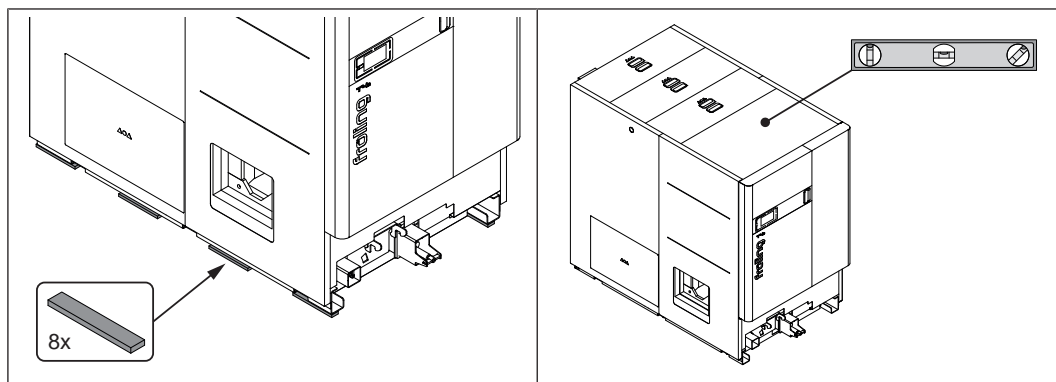

- Lift the boiler using an appropriate lifting device
- Position a Sylomer pad under the boiler base
 - ↳ Sylomer pads prevent the transmission of noise to the ground
- Carefully release the lifting device and check that the boiler is level
- If necessary, level the boiler using load-bearing pads

6.3.2 Installing the pellet suction system

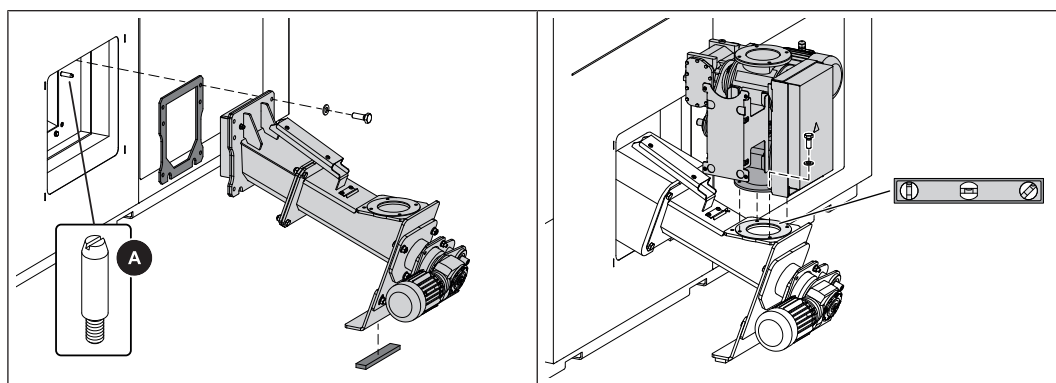

- Remove the stoker cover plates on the right-hand side of the boiler
 - ↳ Stoker cover plates are no longer required
- Position the seal on the connection flange
- Thread the stoker unit onto both lock bolts (A) on the connecting flange and fix in place
 - 4 hexagonal screws M10 x 30
- Position a Sylomer pad under each adjustable foot and align the stoker unit so that it is horizontal
- Mount the rotary valve unit onto the stoker unit as illustrated
 - 4 hexagonal screws M8 x 20

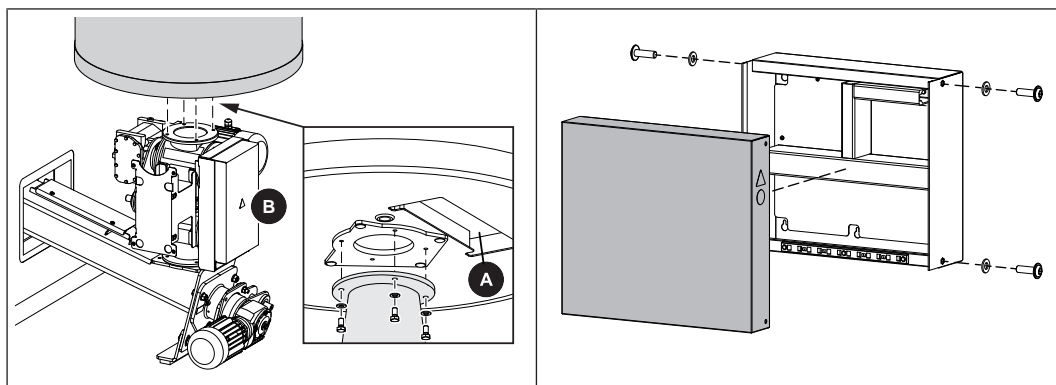

- Secure the cyclone container to the rotary valve unit
 - 4 M8 x 16 hexagon head screws
 - ↳ When doing so, position the cut-out (A) above the housing (B) of the rotary valve
- Remove the cover from the distributor box
 - 4 lens-head screw M6 x 20 incl. contact washer

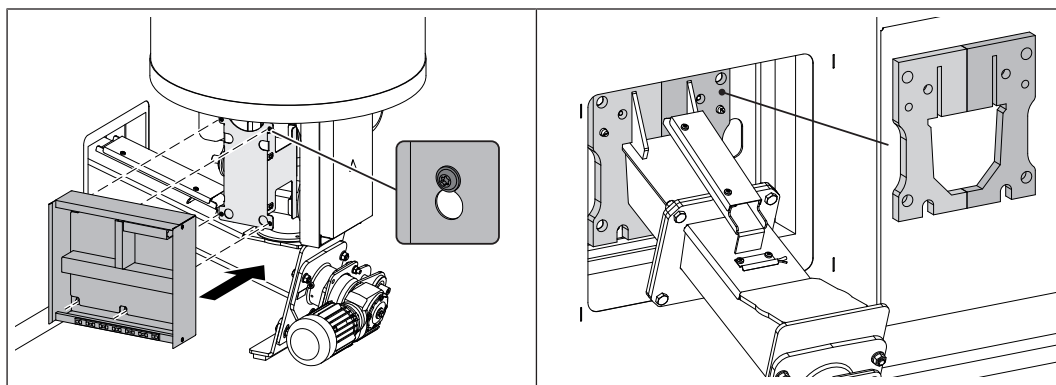

- Loosen the four screws on the distributor box's bracket.
- Hang the distributor box on the screw heads and tighten the screws
- Position the thermal insulation panels on the flange of the stoker as shown

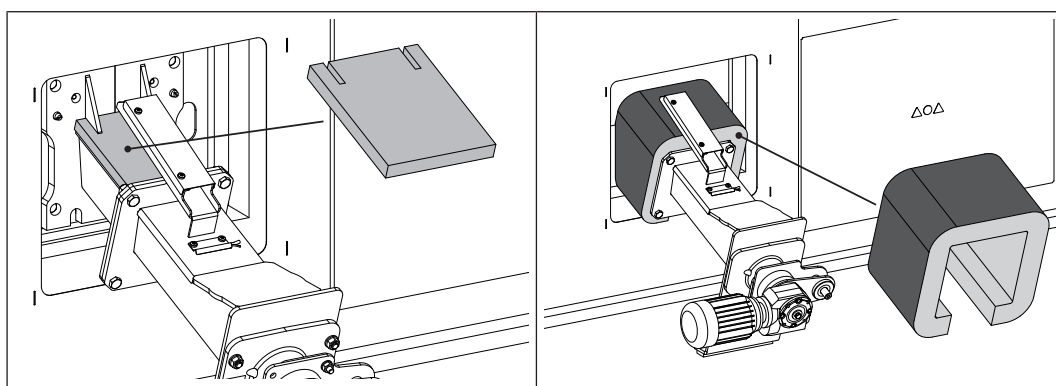

- Position the thermal insulation panels on the stoker as shown
- Wrap thermal insulation around the stoker duct

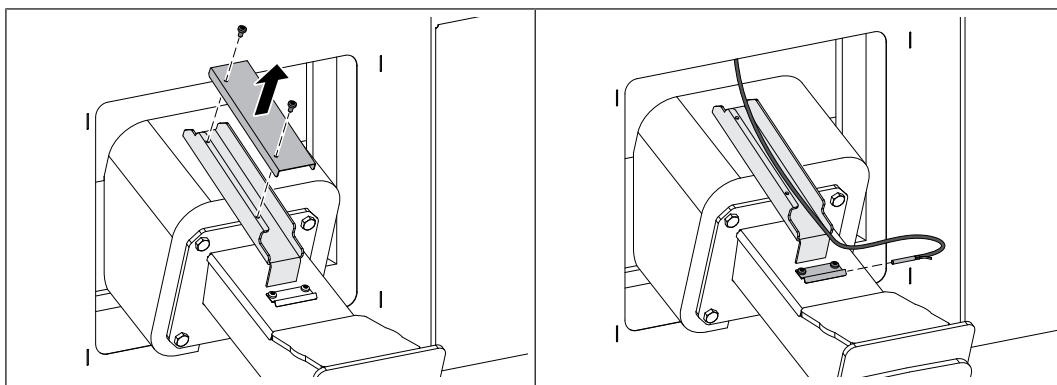

- Remove the cover on the cable duct
- Loosen the screws of the clamping plate on the stoker duct
- Push temperature sensor under clamping plate and fix with screws

6.3.3 Checking the return temperature control (PT4e 200-250)

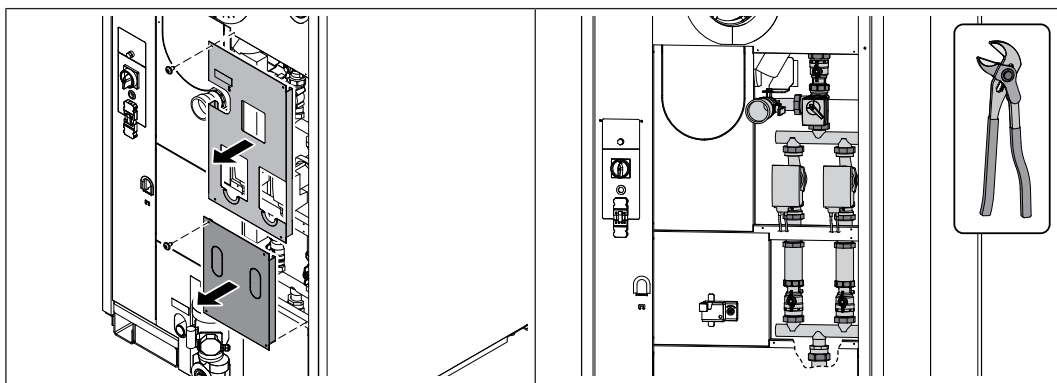

- Remove the rear cover plate on the return as well as the cover plate underneath
- Tighten all of the screw connections on the return temperature control using a pipe wrench
 - ↻ Screw connections may have loosened during transport.
 - ↻ **IMPORTANT:** Before and after filling the system with heated water, check the seal of the screw connections on the return temperature control

6.3.4 Checking the return temperature control (PT4e 300-350)

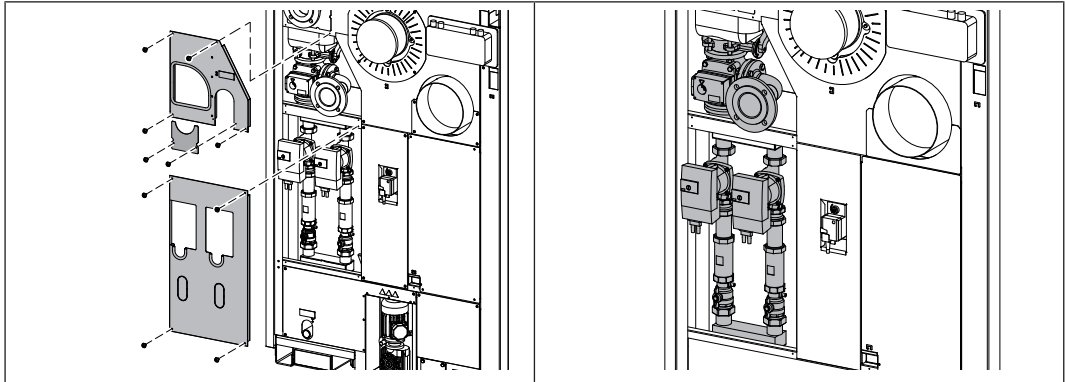

- Remove the back panels
- Check all of the connections on the return temperature control and tighten if necessary
 - ↳ Connections may have loosened during transport.
- IMPORTANT:** Before and after filling the system with heated water, check the seal of the screw connections on the return temperature control

6.3.5 Align the ash container

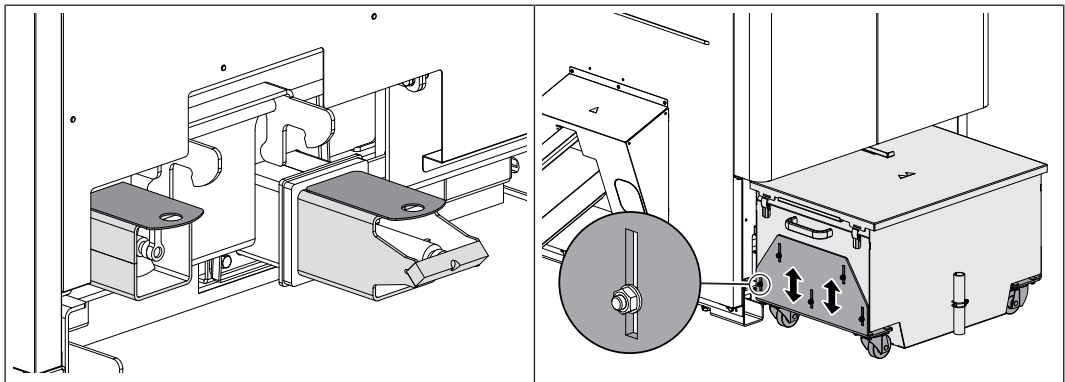

- Place the enclosed spacer plate on both ash channels
- Slide the ash container onto the boiler and attach using clamping lever
- Loosen the screw connection and adjust castors to the ground
- Horizontally align the ash container and attach the screw connection
- Remove the ash container and spacer plate

Check the seals' pressure

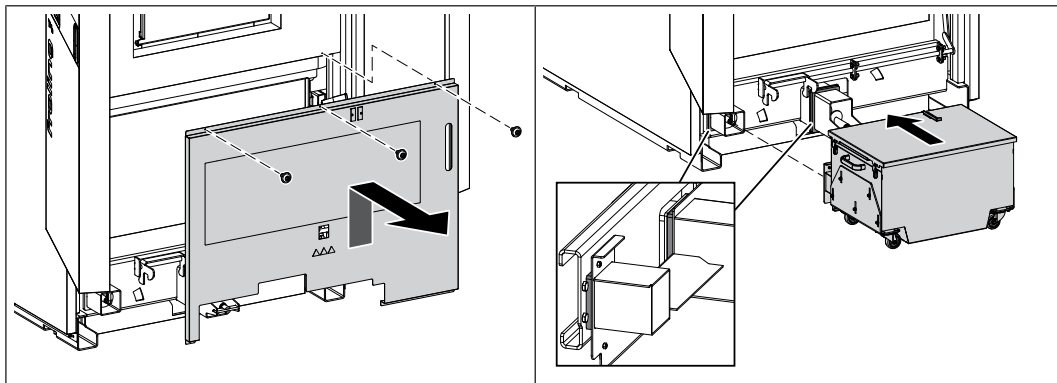

- Open the insulated door and remove the ash box
- Remove the front cover plate
- Slide the ash container onto the boiler and attach using clamping lever
- Check the seals for pressure

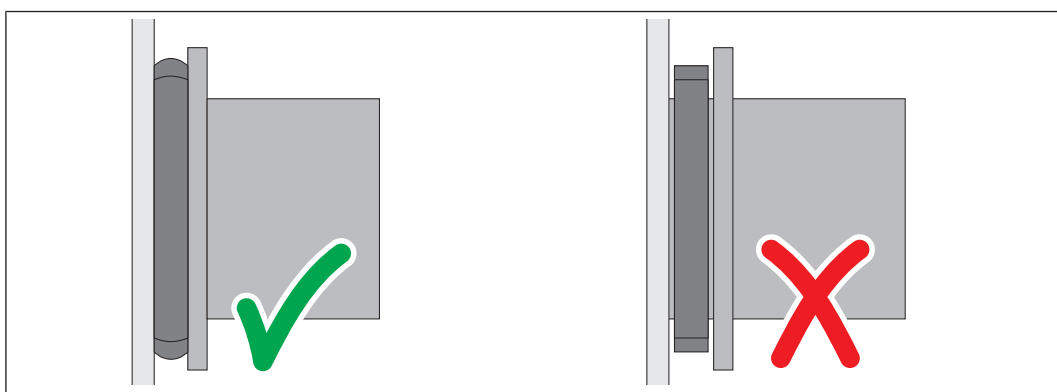

- Seal is visibly pressed on:
 - Adjustment OK
- Seal is found to be loose on the duct
 - Add spacer plate

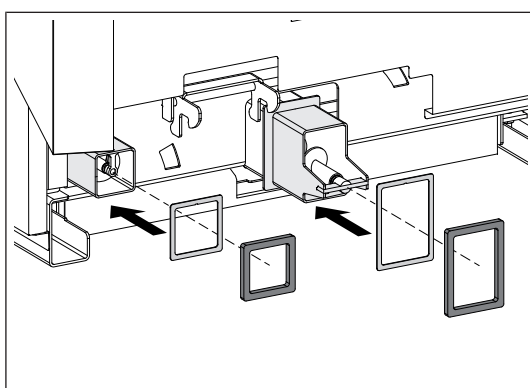

- Pull off the seal on the affected duct
- Slide spacer plate and seal back onto the duct
- Slide the ash container onto the boiler and check the pressure again

6.3.6 Installing the external suction module

The pellets are loaded using an external suction module built into the return air line between the boiler and the suction point.

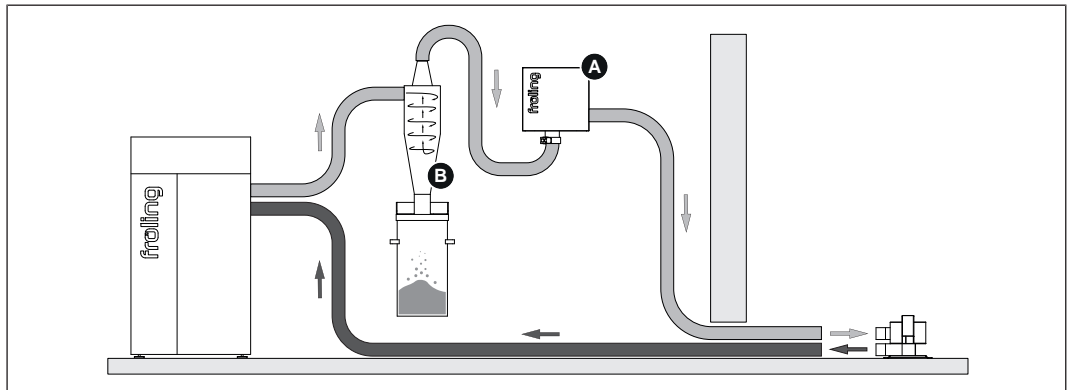

Observe the following points when installing the device:

- The external suction module (A) can be positioned anywhere in the return air line. If using an optional PST pellet deduster (B), install the external suction module between the pellet deduster and fuel store.
- Ensure the assembly materials are suitable before starting installation. Where required, replace by material suitable for the base.
- No specific installation position is required for the suction turbine to operate smoothly. Preferably, the suction module should be installed so that existing openings in the housing are not on the upper side and the suction turbine is protected against external influences.
- Do not switch on the power supply or start up the device until the hose lines have been connected

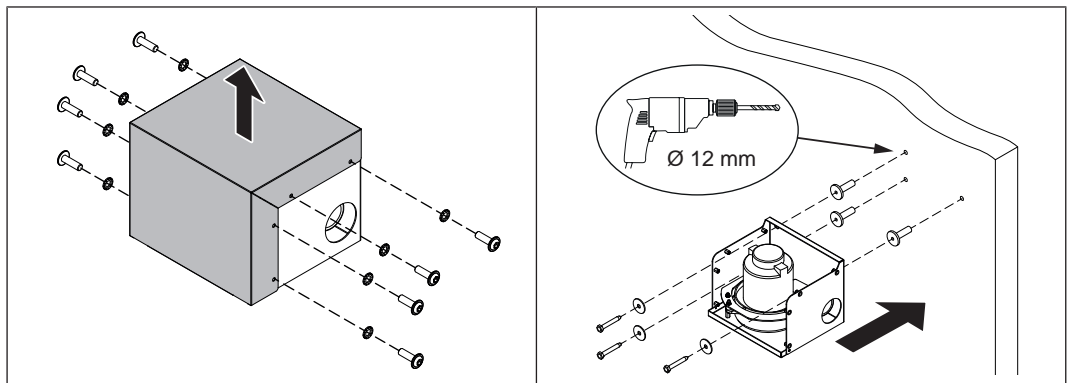

- Undo the screws on the suction module and remove the cover hood
- Install the bottom panel including the supplied dowels and screws at any desired position in the return air line
 - ↳ If the suction module is positioned at a maximum distance of 2 m to the boiler, the power supply line can be plugged in as is. When distances are greater the power supply line must be lengthened accordingly on-site

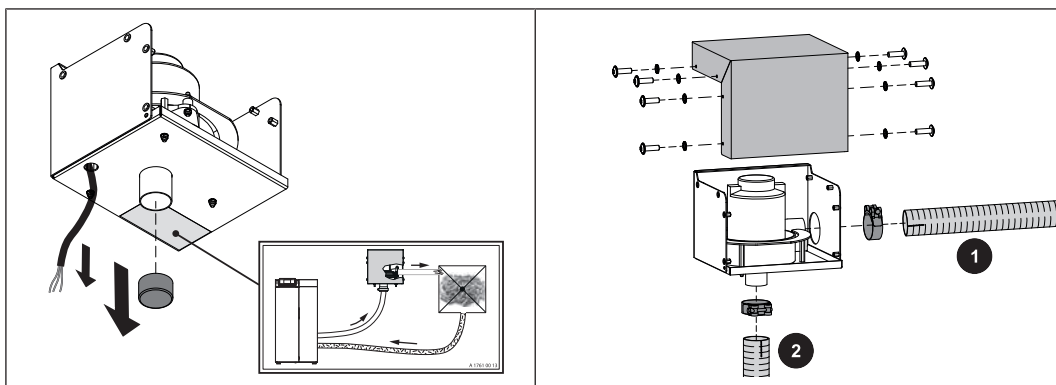

- ❑ Run the cable for the suction turbine through the opening on the bottom and remove the protective cap
- ❑ Fix the hose lines to the connections using hose clamps
 - ↪ Return air line (1) from the suction point to the suction module
 - ↪ Return air line (2) from the suction module to the boiler
 - ↪ **IMPORTANT! In the process, pay attention to the potential equalisation, ⇨**
"Assembly information for hose lines" [▶ 50]
- ❑ Install the cover hood on the suction module

6.3.7 Fit the suction hoses to the boiler

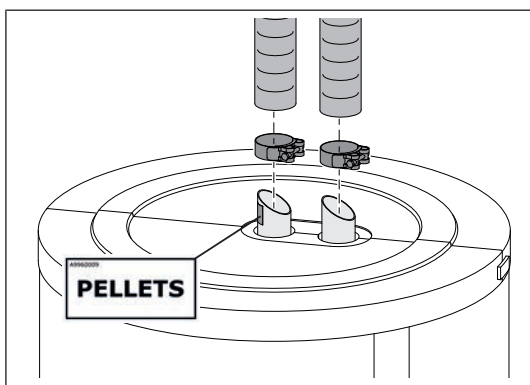

- ❑ Fix the suction hoses to the connections using hose clamps
 - ↪ When doing so, attach the "PELLETS" sticker at the connection point of the pellet suction hose

IMPORTANT! When connecting the suction hoses, pay attention to the equipotential bonding.

6.3.8 Assembly information for hose lines

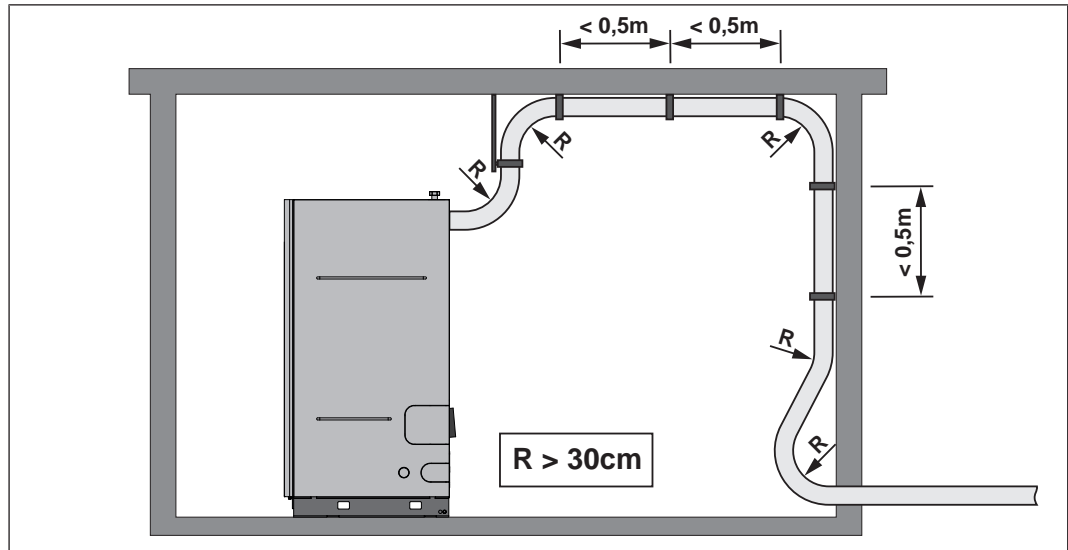

Please note the following:

- Do not kink the hose lines! Minimum bending radius = 30cm
- Lay the hose lines as straight as possible! Sagging lines can lead to so-called “pockets”, which may cause problems with the pellet feed.
- Lay the hose lines in short sections away from walking areas.
- Hose lines are not UV-proof. Therefore: Do not install the hose lines outdoors.
- Hose lines are suitable for temperatures up to 60°C. Therefore: Hose lines must not come into contact with flue gas pipes or uninsulated heating pipes.
- Hose lines must be earthed on both sides to ensure that no static charge builds up as a result of transporting the pellets.
- The suction hose to the boiler must be in a single section.
- The return-air line can be made up of several sections, but consistent potential equalisation must be established throughout the line.
- For systems over 35 kW, only hose lines with PU inlet are recommended due to the increased load

Potential equalisation

IMPORTANT! Ensure consistent potential equalisation when connecting the hose lines!

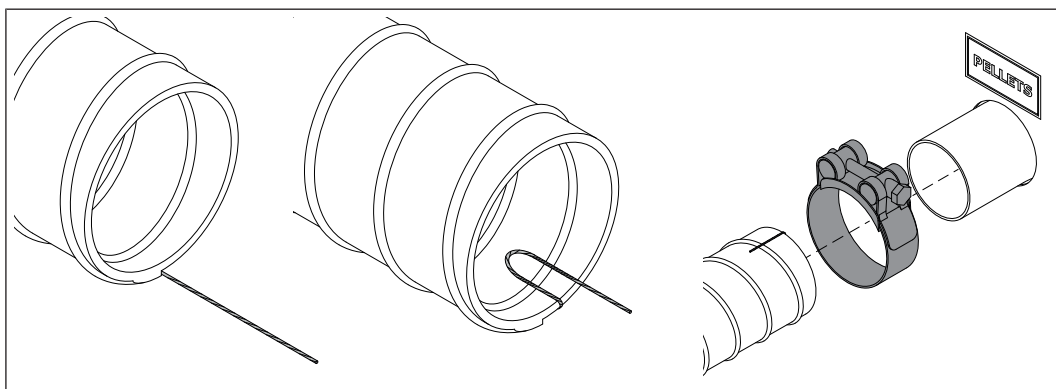

- Expose the earth wire of the hose line to approx. 8 cm
 - ↪ **TIP:** Slit the insulation open along the wire with a knife
- Bend the earth wire inwards in a loop
 - ↪ This prevents the earth wire from being damaged by the pellet movement
- Slide the hose clamp onto the hose line and secure to connector
 - ↪ Ensure that contact is established between the earth wire and the connector. Remove paint from the affected area if necessary
 - ↪ **TIP:** If stiffness occurs when trying to attach the hoses to the connectors, pour a few drops of water onto the pipe (do not use lubrication grease!)

6.4 Hydraulic connection

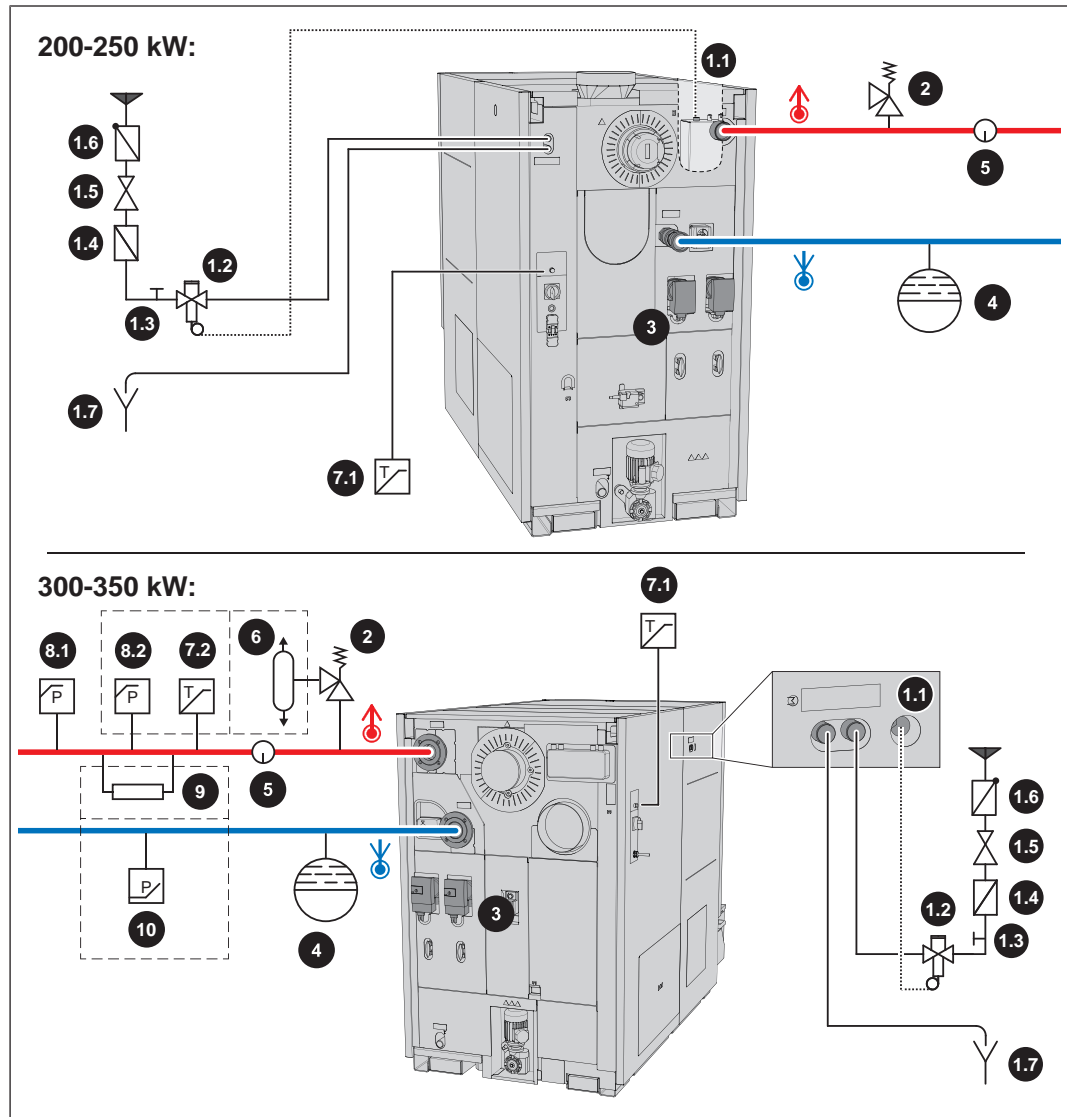

1 Thermal discharge valve

- The thermal discharge safety device must be connected in accordance with ÖNORM/ DIN EN 303-5 and as shown in the diagram above
- The discharge safety sensor must be connected to a pressurised cold water mains supply (temperature $\leq 15^{\circ}\text{C}$) in such a way that it cannot be shut off
- A pressure reducing valve (1.5) is required for a cold water pressure of ≥ 6 bar
Minimum cold water pressure = 2 bar

- 1.1 Sensor of thermal discharge safety device
- 1.2 Thermal discharge valve (opens at approx. 95°C)
- 1.3 Cleaning valve (T-piece)
- 1.4 Dirt trap
- 1.5 Pressure reducing valve
- 1.6 Backflow preventer to prevent stagnation water from entering the drinking water network
- 1.7 Free outlet without counter pressure with observable flow path (e.g. discharge funnel)

2 Safety valve

- Requirements for safety valves as specified by DIN EN ISO 4126-1
- Minimum diameter for the inlet to the safety valve as specified by EN 12828:
DN15 (≤ 50 kW), DN20 (> 50 to ≤ 100 kW), DN25 (> 100 to ≤ 200 kW), DN32 (> 200 to ≤ 300 kW), DN40 (> 300 to ≤ 600 kW), DN50 (> 600 to ≤ 900 kW)

	<ul style="list-style-type: none"> ▪ Maximum pressure setting in terms of the permissible operating pressure of the boiler, see the section “Technical Data” ▪ The safety valve must be installed in an accessible place on the boiler or in direct proximity in the flow pipe in such a way that it cannot be shut off ▪ Unhindered and safe escape of the steam or water that is released must be ensured
3	Return temperature control
4	Diaphragm expansion tank <ul style="list-style-type: none"> ▪ The diaphragm pressurised expansion tank must conform to EN 13831 and hold at least the maximum expansion volume of the heated water in the system, including a water seal ▪ Its size must comply with the design information in EN 12828 - Appendix D ▪ Ideally it should be installed in the return line. Follow the manufacturer’s installation instructions
5	We recommend installing some sort of monitoring device (such as a thermometer)
6	Expansion trap <ul style="list-style-type: none"> ▪ Its dimensions must comply with the design information in EN 12828 - Appendix E ▪ Installation in blow-out line immediately next to the safety valve ▪ At the bottom of the expansion trap, water must be discharged into an unobstructed outlet without counterpressure where the flow path can be observed (e.g., discharge funnel) ▪ At the top of the expansion trap, steam must be discharged safely into the atmosphere <p>IMPORTANT! The expansion trap can be omitted when an additional high-limit thermostat (7.2) and an additional maximum pressure limiter (8.2) are integrated into the installation</p>
7.1	High-limit thermostat <ul style="list-style-type: none"> ▪ Integrated into the boiler at the factory
7.2	Additional high-limit thermostat IMPORTANT! Omitted if an expansion trap (6) is integrated in the installation
8.1	Maximum pressure limiter <ul style="list-style-type: none"> ▪ The system is switched off when the maximum pressure in the boiler flow connection is exceeded. As soon as the system has dropped to the specified working pressure, the system is unlocked by activating the reset button manually.
8.2	Additional maximum pressure limiter <ul style="list-style-type: none"> ▪ The system is switched off when the maximum pressure in the boiler flow connection is exceeded. As soon as the system has dropped to the specified working pressure, the system is unlocked by activating the reset button manually. <p>IMPORTANT! Omitted if an expansion trap (6) is integrated in the installation</p>
9	Water shortage safety device <ul style="list-style-type: none"> ▪ When the water level in the boiler is too low, the system is switched off; thus, overheating of the boiler is prevented <p>IMPORTANT! Omitted if a minimum pressure limiter (10) is used in the installation</p>
10	Minimum pressure limiter <ul style="list-style-type: none"> ▪ The system is switched off when the minimum pressure in the boiler’s return flow connection drops below its preset value. As soon as the system has reached the specified working pressure, the system is unlocked by activating the reset button manually. <p>IMPORTANT! Omitted if a water shortage safety device (9) is integrated in the installation</p>

6.5 Electrical connection

DANGER



When working on electrical components:

Risk of electrocution!

When work is carried out on electrical components:

- Always have work carried out by a qualified electrician
- Observe the applicable standards and regulations
 - ↳ Work must not be carried out on electrical components by unauthorised persons

CAUTION



If cables come into contact with hot surfaces:

Possible fire hazard of the system and electric shock!

The following applies to assembly work:

- Keep cables away from boiler components that become hot during operation (e.g. stoker duct, inspection cover, flue gas pipe, ash removal, etc.)
- Lay cables in the cable ducts provided and use cable ties to secure against slipping

Prepare the plug some components come ready to connect with the cable fixed to the tag connector with cable tie.

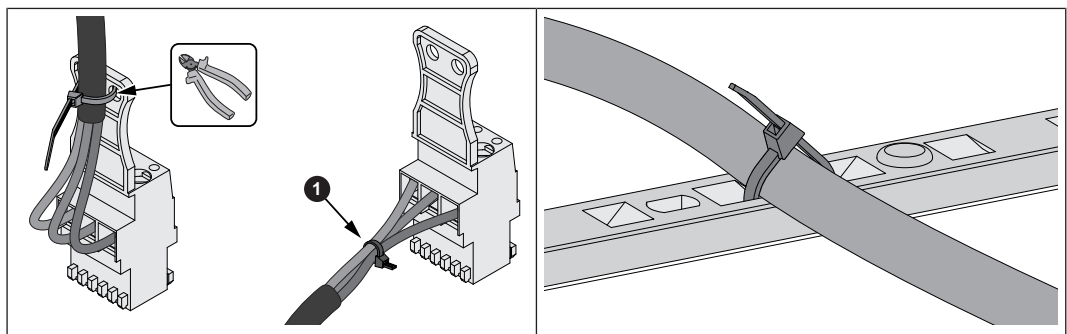

- Remove the cable ties from the tag connector
- Bind the individual cores together with cable ties (A)
- Attach cable and cable ties to the strain reliefs on the boiler

- Flexible sheathed cable must be used for the wiring; this must be of the correct size to comply with applicable regional standards and regulations
 - ↳ YMM to ÖVE-K41-5 or H05VV-F to DIN VDE 0881-5

6.5.1 Board overview

PT4e 200-250

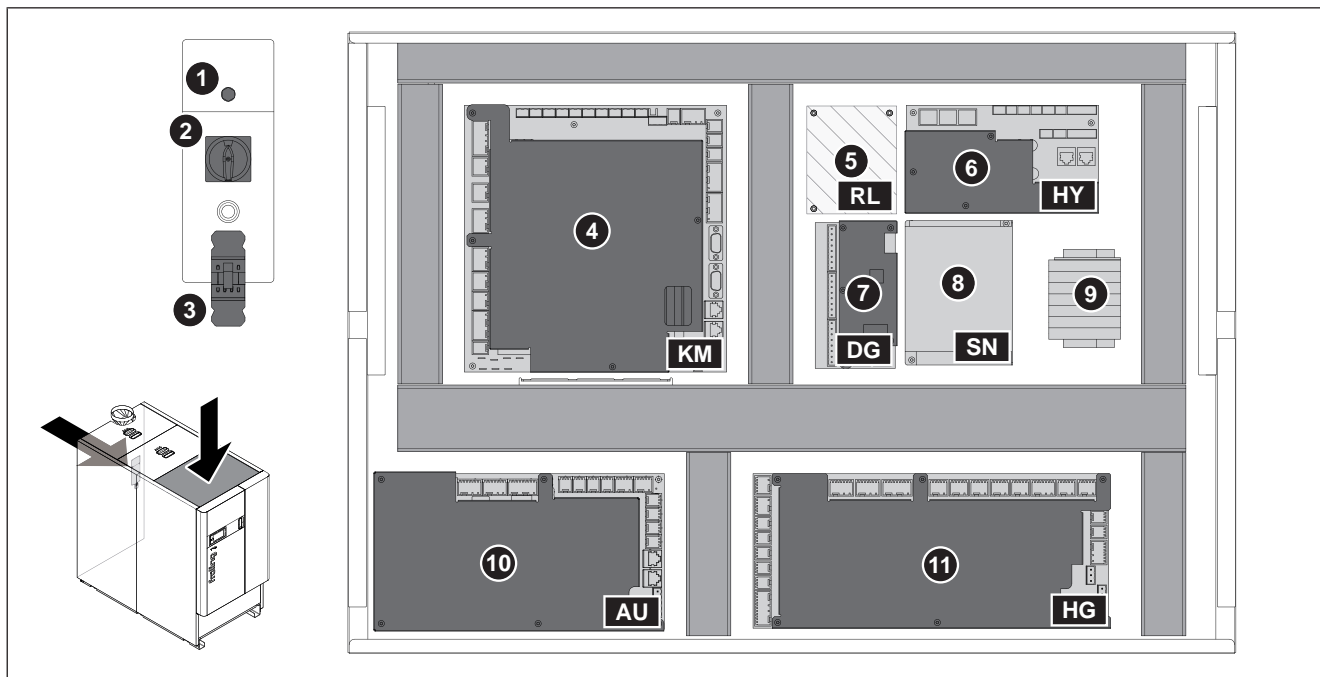

Item	Description	Item	Description
1	High-limit thermostat (STL)	7	Digital module (address 1)
2	Main switch	8	Plug power pack
3	Mains connection plug	9	Terminal blocks
4	Core module	10	Feed system module (address 0)
5	Return mixer module (not used)	11	Wood chip module
6	Hydraulic module		

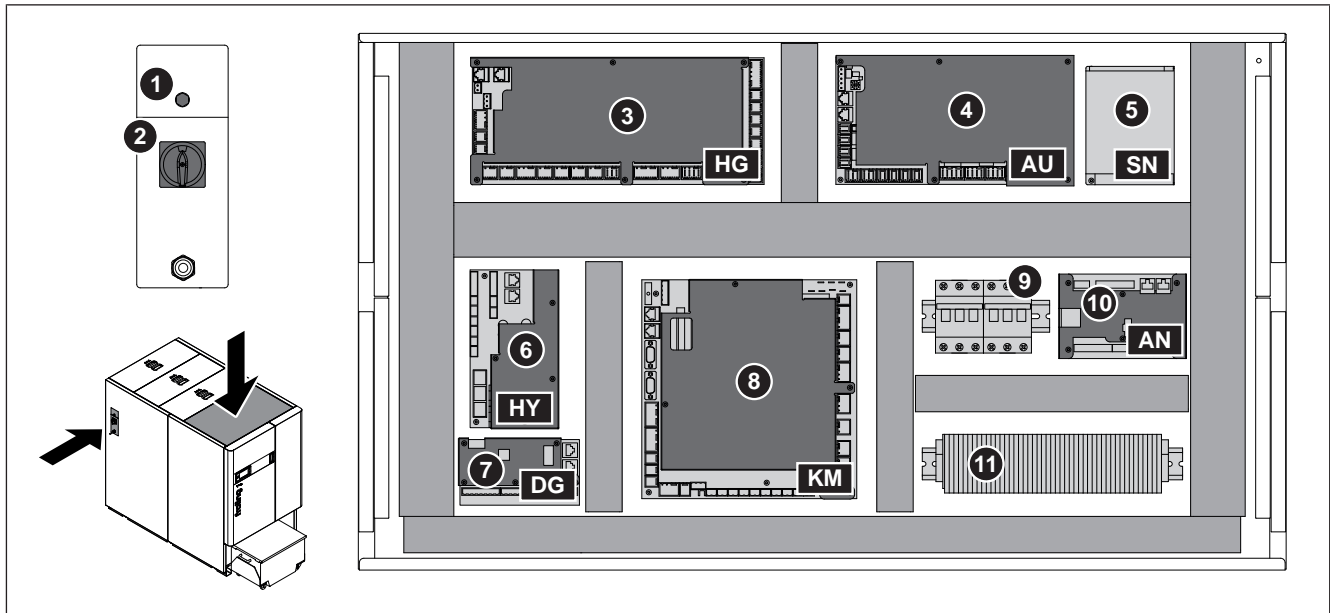
PT4e 300-350

Item	Description	Item	Description
1	High-limit thermostat (STL)	7	Digital module
2	Main switch	8	Core module
3	Wood chip module	9	Line protective circuit breaker, 3-pole
4	Feed system module	10	Analogue module
5	Plug power pack	11	Terminal blocks
6	Hydraulic module		

Distributor box PT4e 200-250

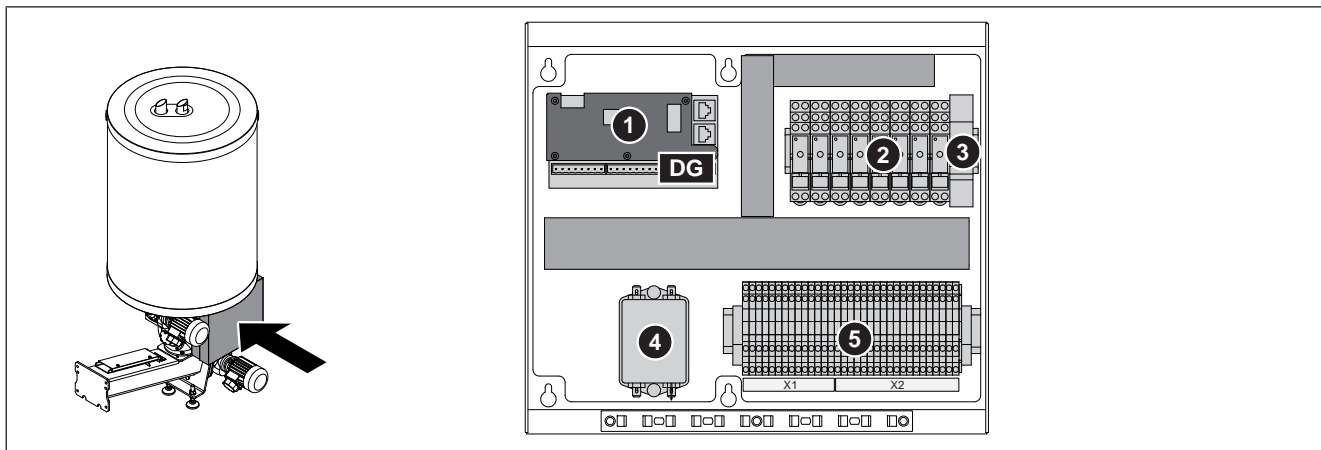

Item	Description	Item	Description
1	Digital module (address 3)	4	Mains filter
2	Relay	5	Terminal blocks
3	Line protective circuit breaker		

External feed system module in the wall-mounted cabinet (if using pellet suction screw with change-over)

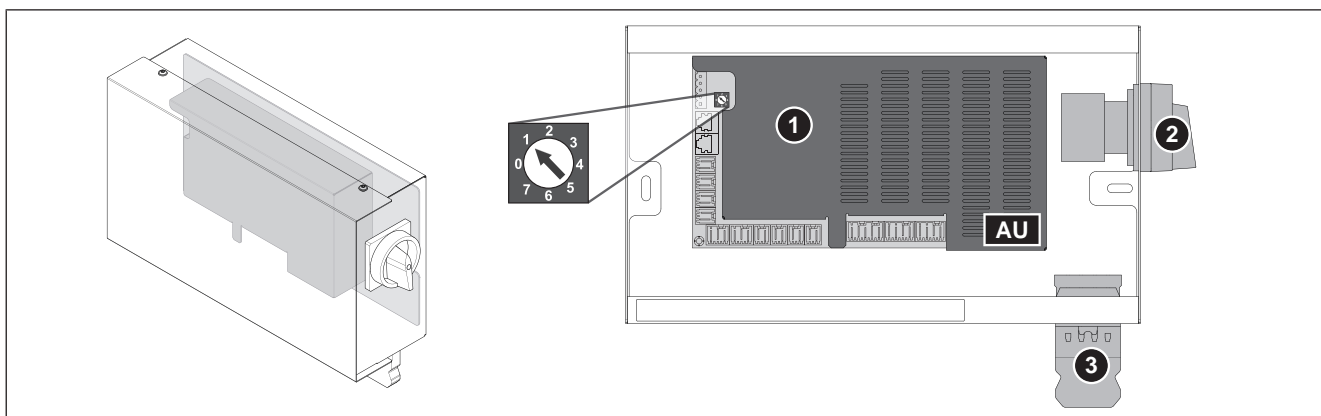

Item	Description	Item	Description
1	Feed system module (address 1)	3	Power supply plug
2	Main switch		

6.5.2 Lay the cable to the boiler controller

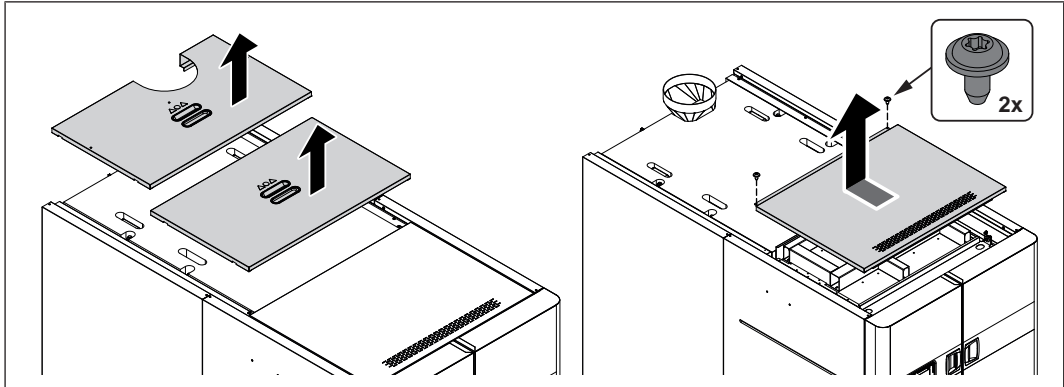

- Remove the insulating cover and thermal insulation
- Undo the retaining screws and contact washers on the controller cover
- Slide the controller cover back and lift off

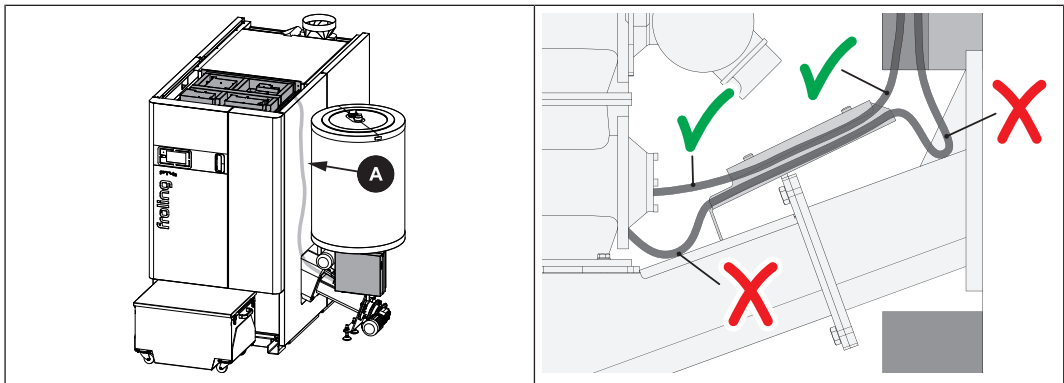

- Install the cables of all components to the boiler controller via a cable duct (A), ➔ "[Lay the cable to the boiler controller](#)" [▶ 58]
- Ensure that the cables do not touch the hot boiler components
 - ↳ Compliance with the warning sign is mandatory, ➔ "[Electrical connection](#)" [▶ 54]
 - ↳ Do not install cable across sharp edges

6.5.3 Connect the suction unit components

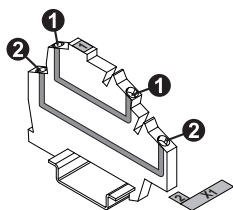

Some components are connected using double deck terminal blocks located inside the suction unit's distributor box. These double deck terminal blocks consist of two separate decks in which the centre connections (1) and the outer connections (2) are connected to each other. The numbered identifications of the centre connections (1) are located centrally to the terminal; the numbered identifications of the outer connections (2) are adhesively mounted in front of the terminal.

- ❑ All connections shall be carried out according to the attached circuit diagram
- ❑ Flexible sheathed cable must be used for the wiring; this must be of the correct size to comply with applicable regional standards and regulations

Connect the 230 V power supply line

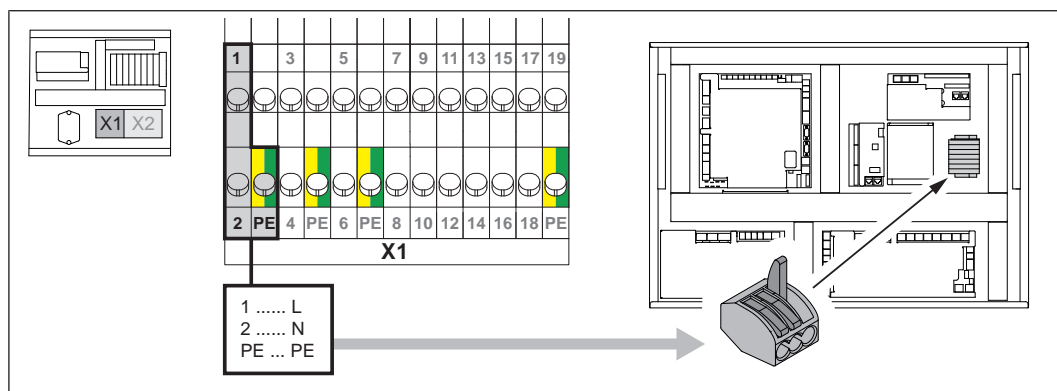

- ❑ Connect the 230 V power supply line from the distributor box to the connection terminals inside the boiler controller
 - ↪ Use the connection terminals to connect to the existing cabling
 - ↪ Connecting cable 3 x 1.5 mm² with earth conductor

Connect the suction turbine

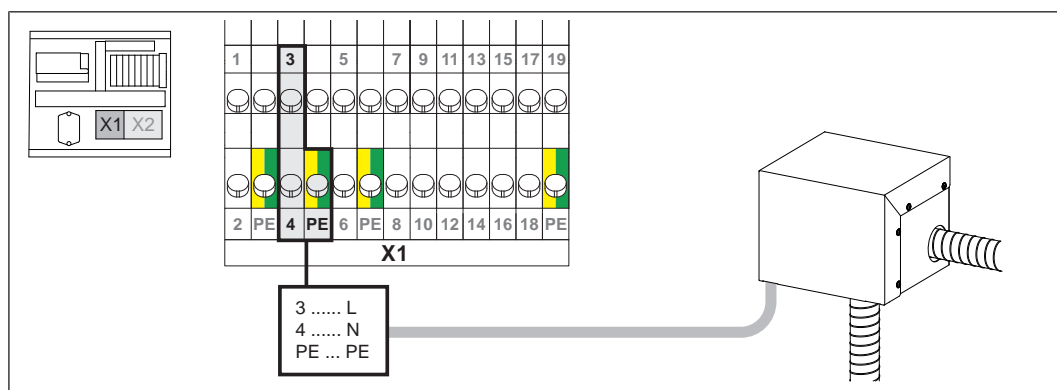

- ❑ Connect the suction turbine's power supply line inside the distributor box
 - ↪ Connecting cable 3 x 1.5 mm² with earth conductor

Connect the fill level sensors

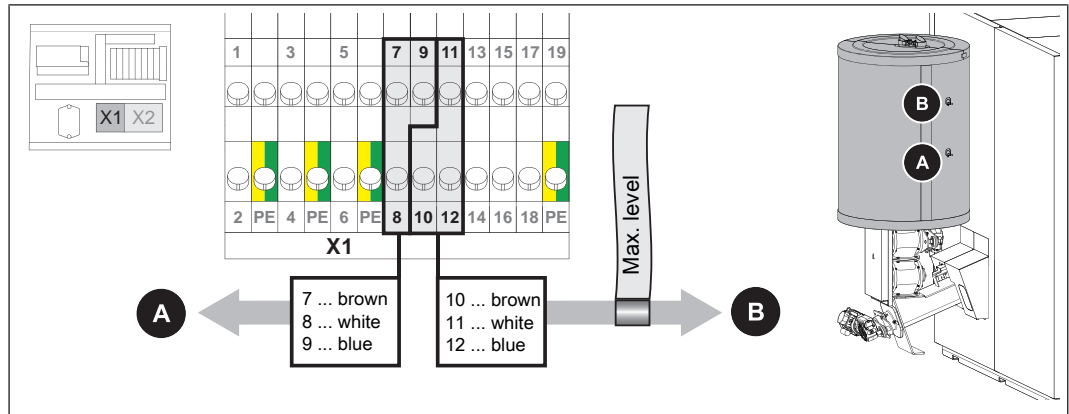

- Connect both fill level sensors of the cyclone container inside the distributor box
 - ↳ Upper fill level sensor (B) with “Max. level” marking
 - ↳ Connecting cable 3 x 1 mm² without earth conductor

Connect the power supply line 24V DC

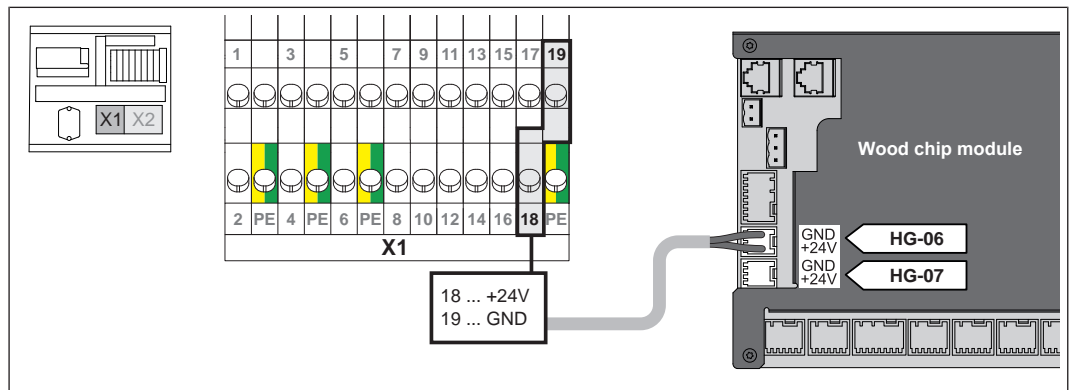

- Connect the 24 V power supply line from the distributor box to the wood chip module inside the boiler controller
 - ↳ Connecting cable 2 x 1 mm² without earth conductor

Connect the temperature sensor of the stoker monitoring unit

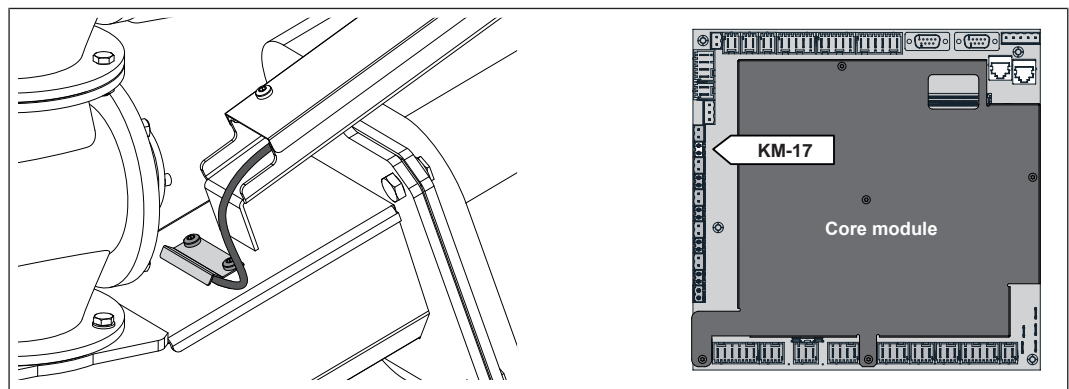

- Connect the temperature sensor of the stoker monitoring unit at the core module in the boiler controller

Connecting the geared motor of the stoker screw

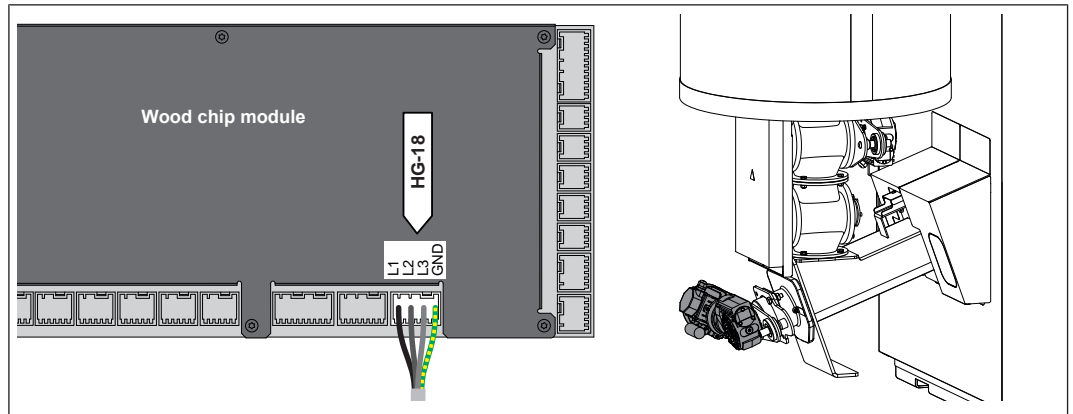

- Connect the supply cable for the geared motor of the stoker screw to the wood chip module in the boiler controller
- ↳ Connecting cable 4 x 1.5 mm² with earth conductor

Connecting the geared motor of the double rotary valve

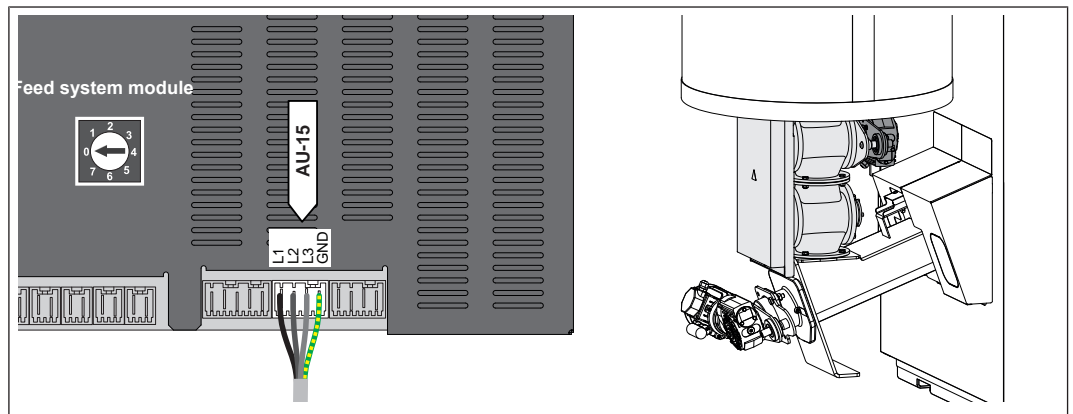

- Connect the supply cable for the geared motor of the double rotary valve to the feed system module
- ↳ Connecting cable 4 x 1.5 mm² with earth conductor

Establish bus connection

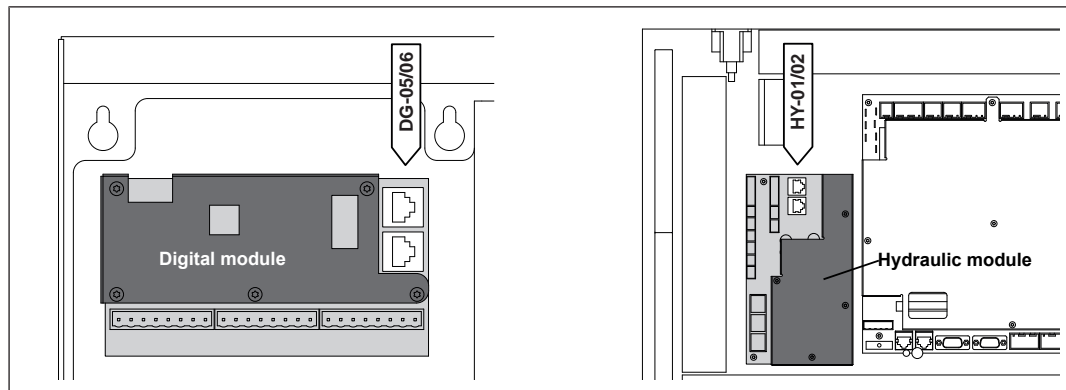

- ❑ Use a vacant port to establish a bus connection from the digital module inside the distributor box to the hydraulic module inside the boiler control
 - ↳ Patch cable CAT 5 RJ45 SFTP 1:1 configuration

Check the digital module

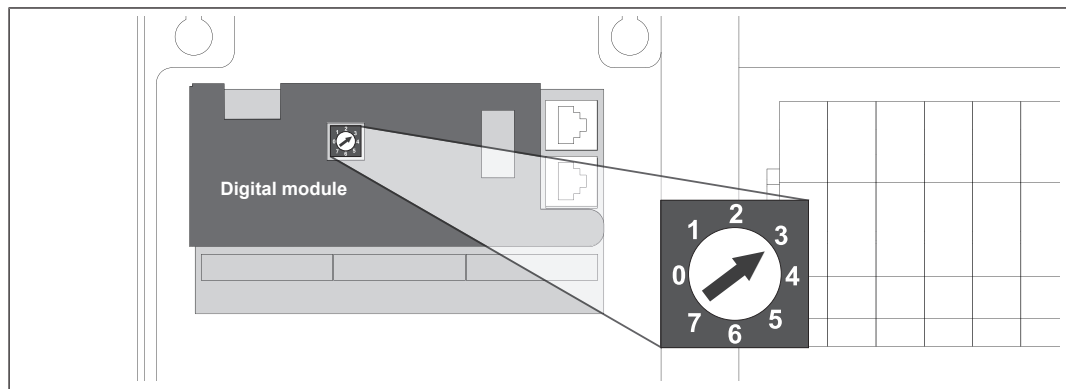

- ❑ Set the module address of the digital module inside the distributor box to “3”

6.5.4 Connect an individual discharge systems

Depending on the conditions of the fuel store, the following pellet discharge systems can be connected:

- Bag silo, Cube RS 4 manual or individual probe
- Pellet mole
- Pellet suction screw
- RS 4 / RS 8 pellet suction system

IMPORTANT! Observe the enclosed installation and operating instructions of the discharge system used. Observe the installation instructions for hose lines, ["Assembly information for hose lines" \[▶ 50\]](#)

Bag silo / Cube / RS 4 manual / individual probe

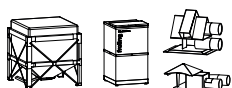

When using a bag silo, cube, RS 4 manual or individual probe, additional electrical wiring is not required.

In addition for bag silo with shaker:

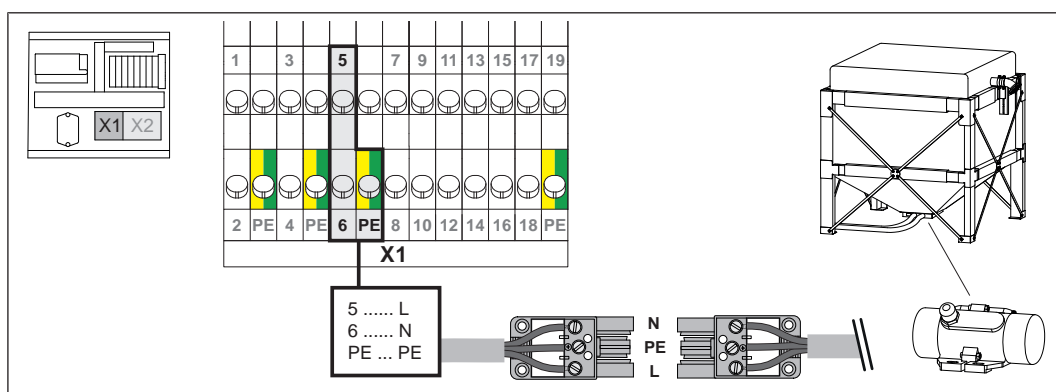

- ☐ Connect the power supply line from the distributor box to the socket of the extension cable and onto the shaker
 - ↳ Connecting cable 3 x 1.5 mm² with earth conductor

Pellet mole

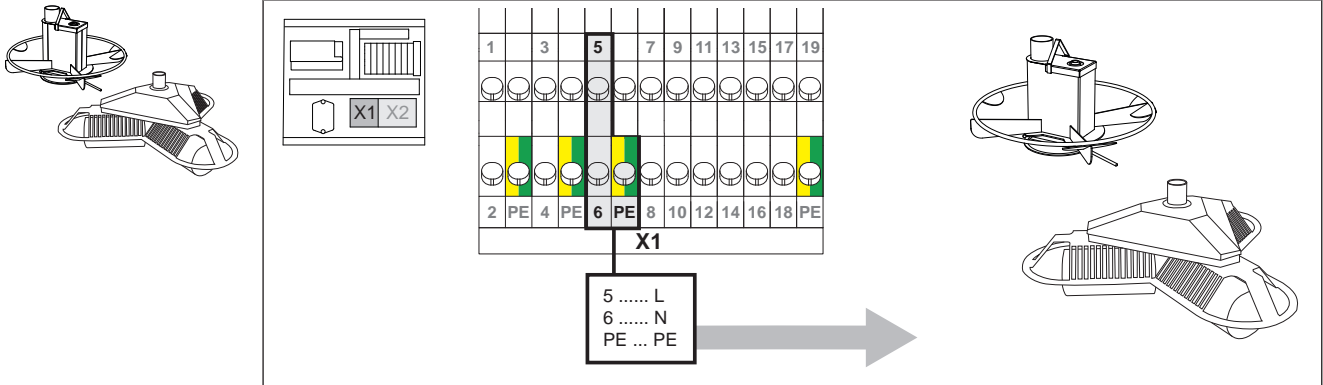

- ❑ Establish the power supply line from the distributor box to the plug connection or the mole junction box
 - ↳ Connecting cable 3 x 1.5 mm² with earth conductor

Pellet suction screw

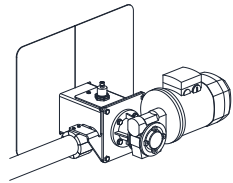

IMPORTANT! A feed system module is integrated in the boiler's controller box.

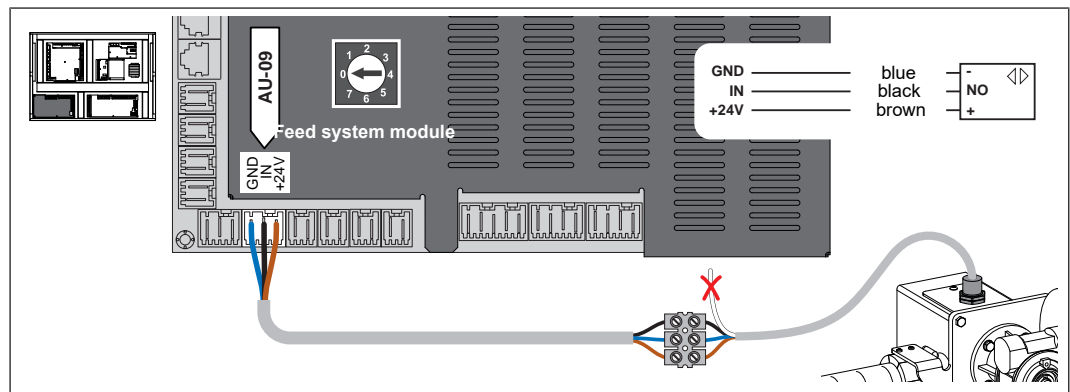

- ❑ Connect the sensor of the pellet suction screw to the boiler controller. The connection can be found on the feed system module
 - ↳ Connecting cable 3 x 0.75 mm² without earth conductor

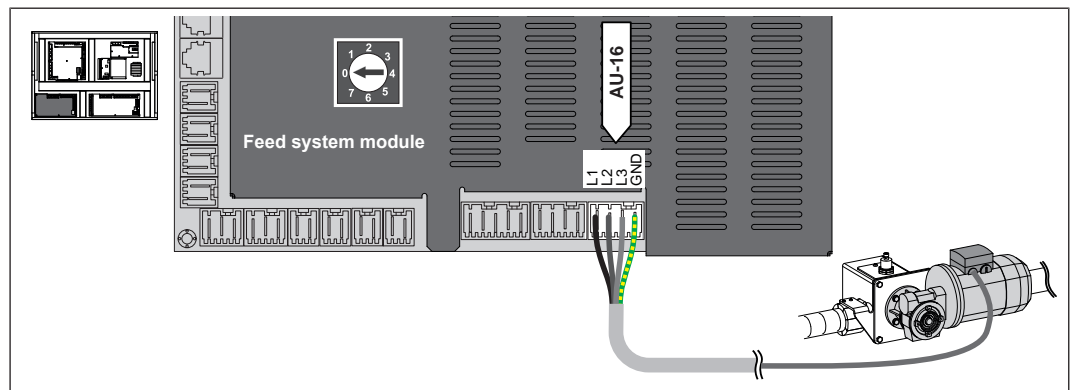

- ❑ Connect the geared motor of the pellet suction screw to the boiler controller. The connection can be found on the feed system module
 - ↳ Connecting cable 4 x 1.5 mm² with earth conductor, max. 0.75kW / 400V

RS 4 / RS 8 pellet suction system

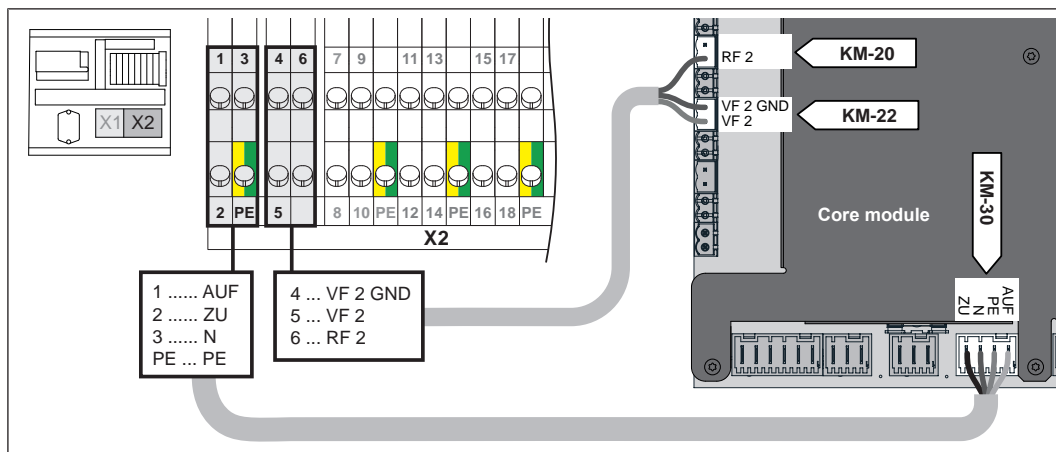
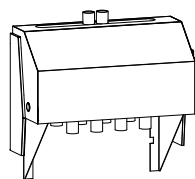

- Install the connection line for the motor control and position control from the distributor box to the core module inside the boiler controller
 - ↳ Connecting cable 4 x 0.75 mm² with earth conductor, max. 0.15kW / 230V
 - ↳ Connecting cable 3 x 0.75 mm² without earth conductor, screened if longer than 25 m

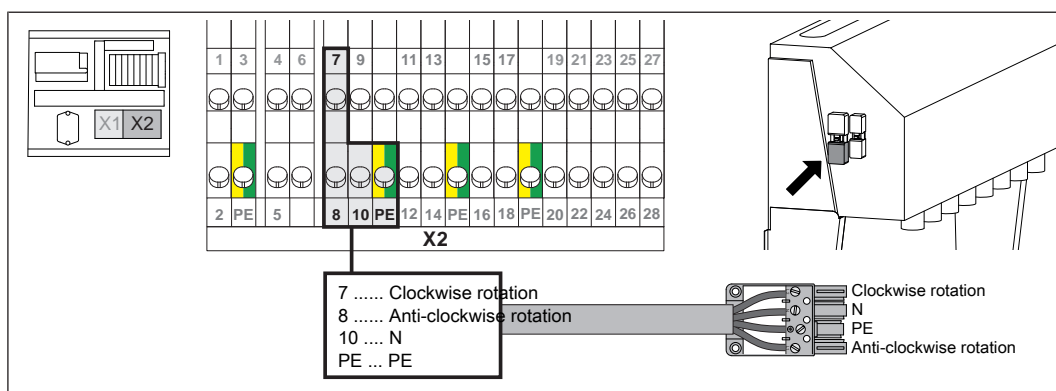

- Attach the connection line for the motor control from the distributor box to the 4-pin plug of the change-over unit
 - ↳ Connecting cable 4 x 0.75 mm² with earth conductor

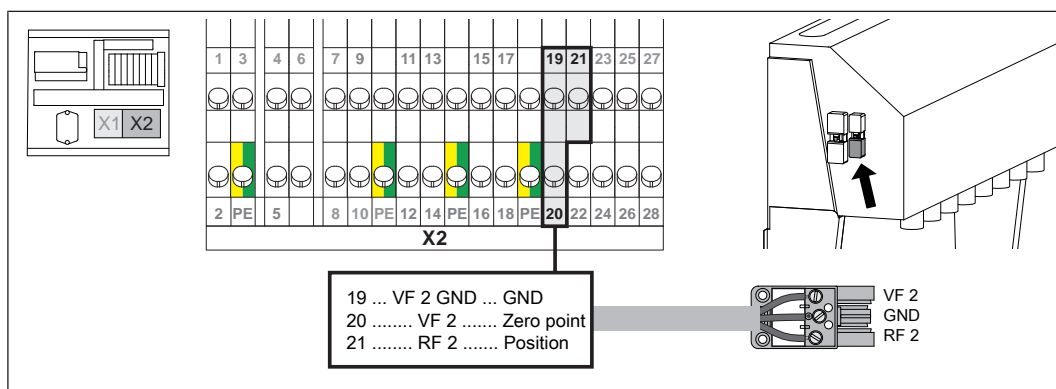

- Establish a connection line for the position control from the distributor box to the 3-pin plug of the change-over unit
 - ↳ Connecting cable 3 x 0.75 mm² without earth conductor

6.5.5 Connect multiple discharge systems with change-over units

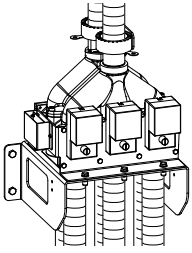

When using the 1-2-3 suction module, up to three discharge systems of the same boiler can be used:

- Bag silo, Cube, RS 4 manual or individual probe
- Pellet mole
- Pellet suction screw
- RS 4 / RS 8 pellet suction system

IMPORTANT! Observe the enclosed installation and operating instructions of the discharge system used. Compliance with the hose line's installation instructions is mandatory, [↻ "Assembly information for hose lines" \[► 50\]](#)

Bag silo / Cube / RS 4 manual / individual probe with change-over

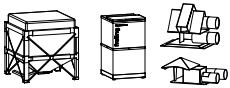

IMPORTANT! All types of these systems can be combined (e.g. 2 bag silos and 1 cube).

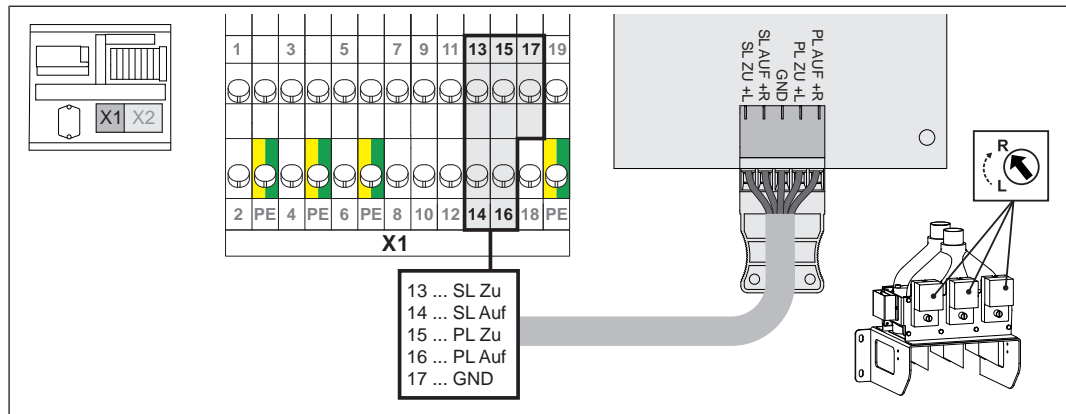

- Establish a connection line from the distributor box to the circuit board on the suction module
 - ↳ Connecting cable 5 x 0.75 mm² without earth conductor
- Set the direction of rotation of the servo-motor to right (R)

Additional information for bag silos with shakers

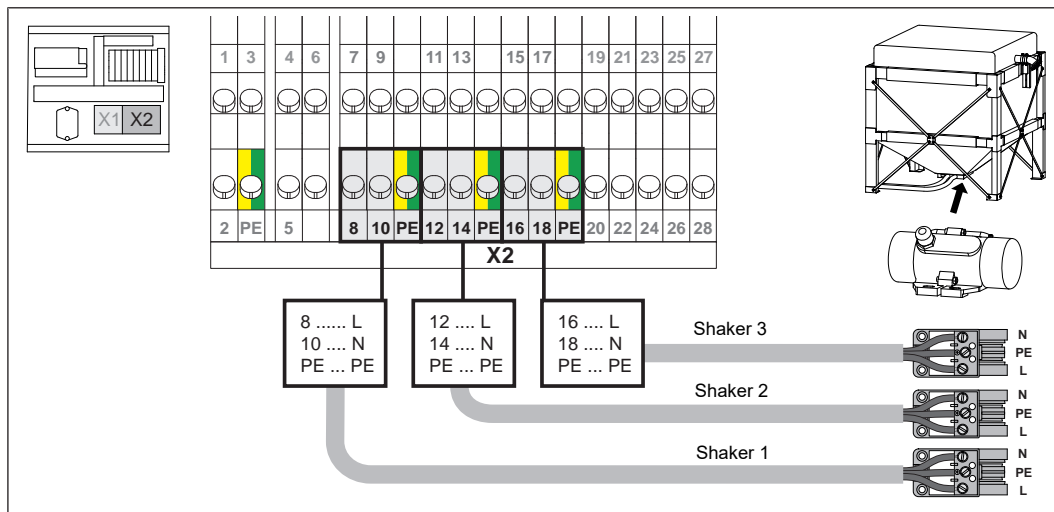

☐ Prepare power supply lines from the distributor box to the sockets of the extension cables on the shakers.

↳ Connecting cable 3 x 1.5 mm² with earth conductor

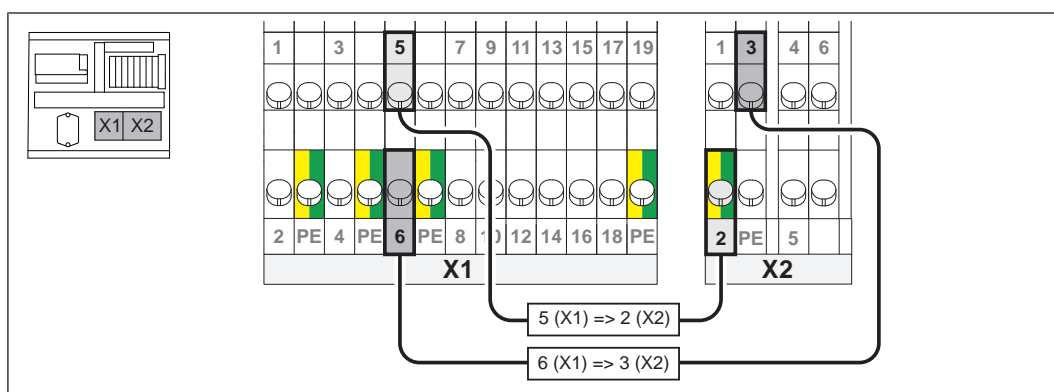

☐ Create a connection line for the enabling signal from terminal block X1 to X2.

↳ Connecting cable 2 x 1.5 mm² without earth conductor

Pellet mole with change-over

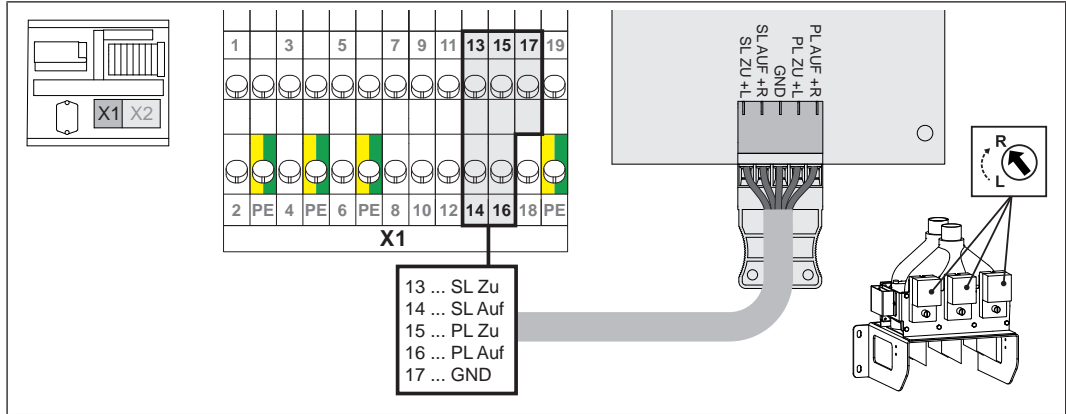
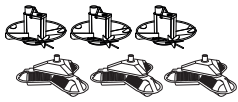

- Establish a connection line from the distributor box to the circuit board on the suction module
 - ↳ Connecting cable 5 x 0.75 mm² without earth conductor
- Set the direction of rotation of the servo-motor to right (R)

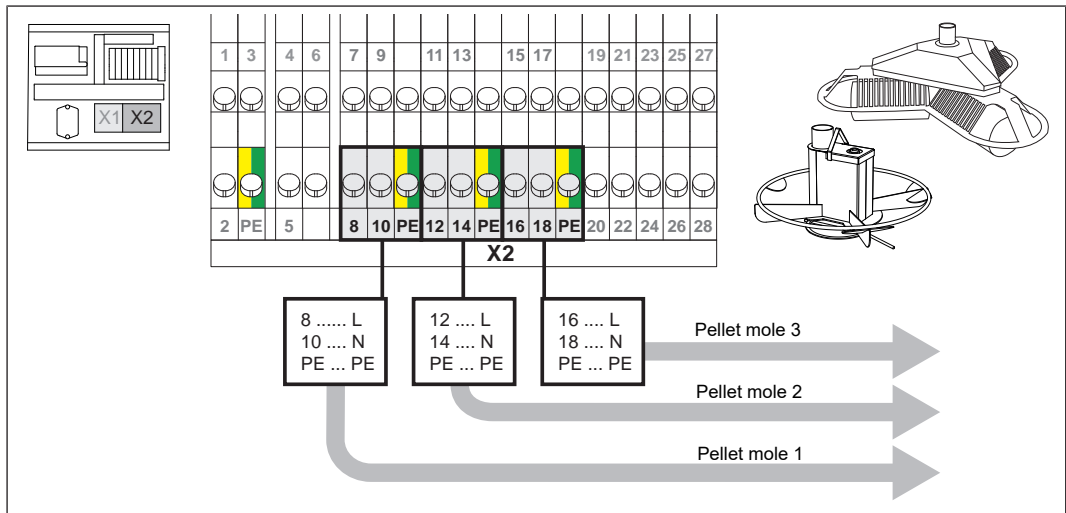

- Establish power supply lines from the distributor box to the plug-in connections (Pellets Mole Classic) or connection boxes (Pellets Mole E3)
 - ↳ Connecting cable 3 x 1.5 mm² with earth conductor

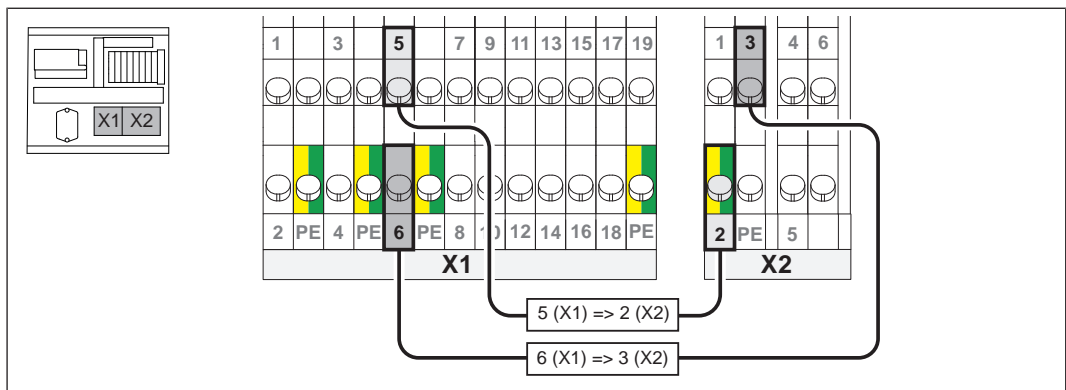

- Create a connection line for the enabling signal from terminal block X1 to X2.
 - ↳ Connecting cable 2 x 1.5 mm² without earth conductor

Pellet suction screw with change-over feature

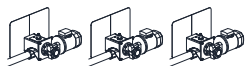

IMPORTANT! For the electrical wiring of the components an additional discharge module is required.

Perform the following steps on the feed system module:

- Establish BUS connection to boiler
- Establish 24V connection to boiler
- Power supply 400 V must be provided by the customer
- Connecting the lock
- Inputs not used for gravity shaft covers must be closed using a wire jumper
- Check end jumper
- Check module address

IMPORTANT! See feed system module installation instructions for more details

Diagram of electrical connection of feed systems:

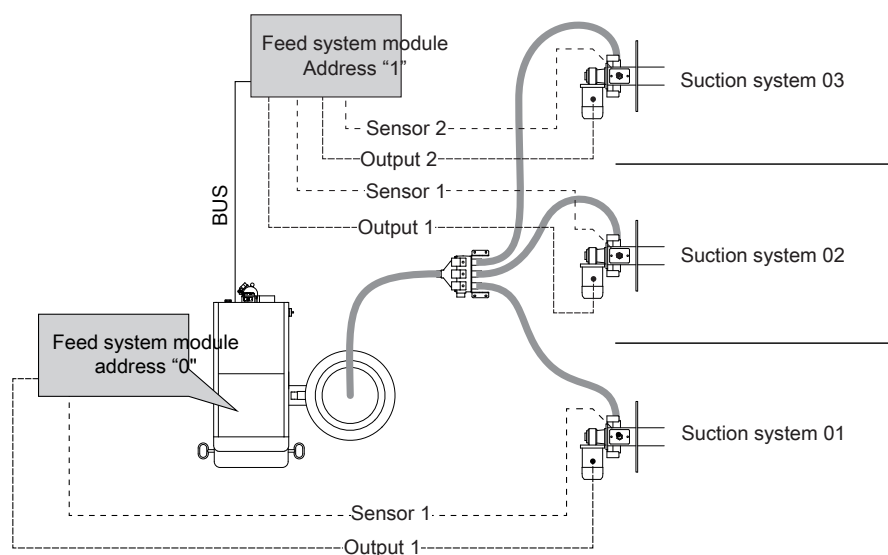

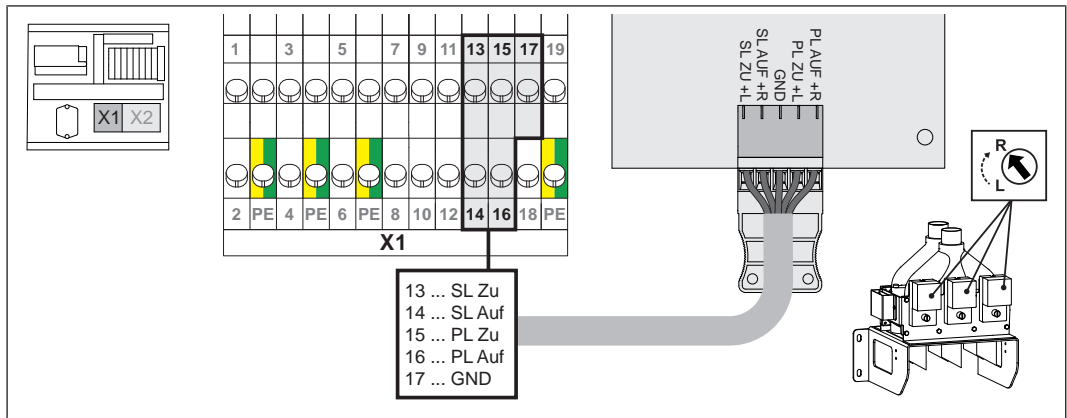

- Establish a connection line from the distributor box to the circuit board on the suction module
 - ↳ Connecting cable 5 x 0.75 mm² without earth conductor
- Set the direction of rotation of the servo-motor to right (R)

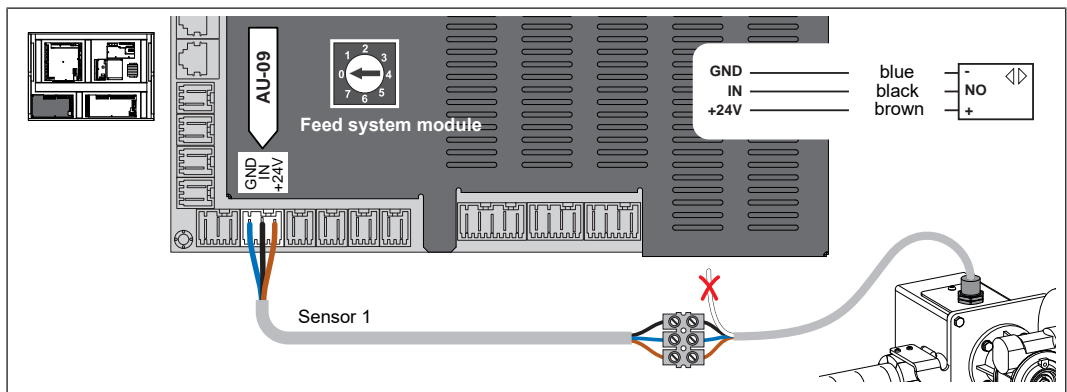

- Connect the sensor of the pellet suction screws 1, which is located on the feed system module (address 0), inside the wall-mounted cabinet
 - ↳ Connecting cable 3 x 0.75 mm² without earth conductor

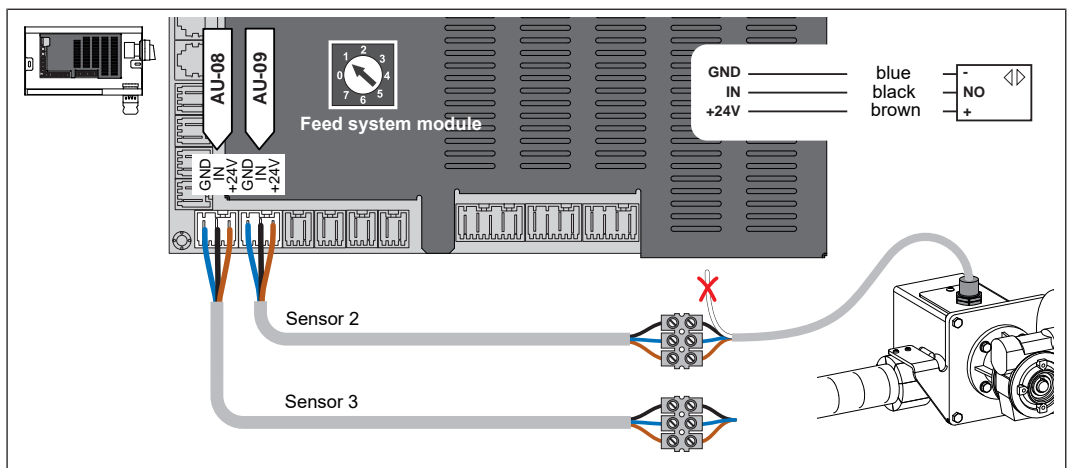

- Connect the sensors of the pellet suction screws 2 and 3, which are located on the feed system module (address 1), inside the wall-mounted cabinet
 - ↳ Connecting cable 3 x 0.75 mm² without earth conductor

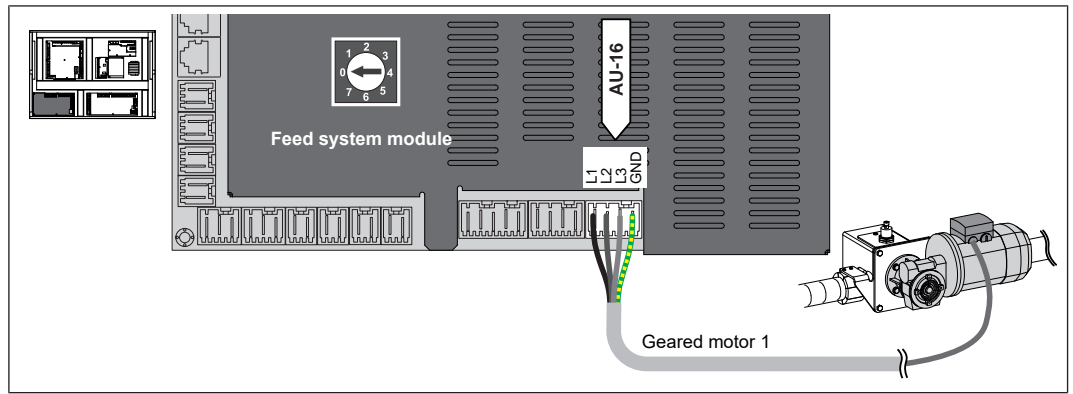

- Connect the geared motor of the pellet suction screws 1, which is located on the feed system module (address 0), inside the boiler controller

↳ Connecting cable 4 x 1.5 mm² with earth conductor, max. 0.75kW / 400V

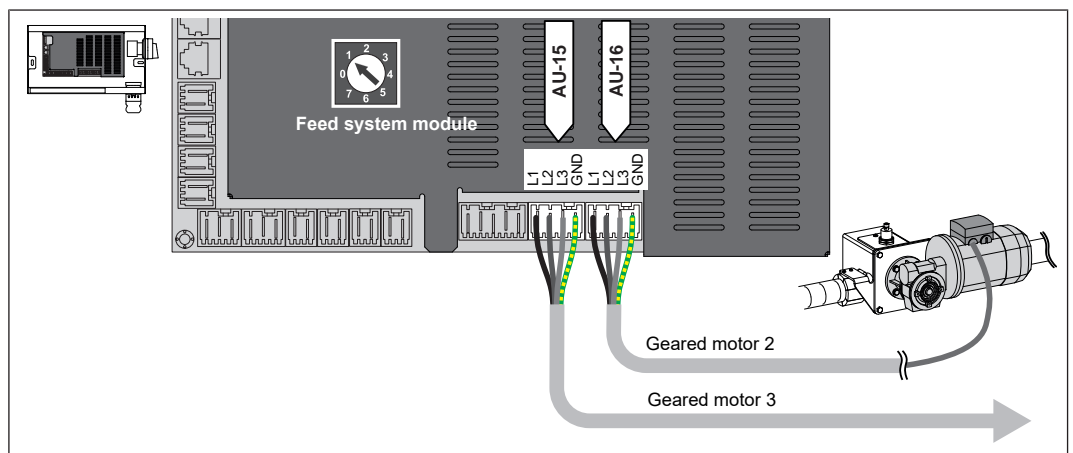

- Connect the geared motor for the pellet suction screws 2 and 3, which are located on the feed system module (address 1), inside the wall-mounted cabinet

↳ Connecting cable 4 x 1.5 mm² with earth conductor, max. 0.75kW / 400V

RS 4 / RS 8 pellet suction system with change-over

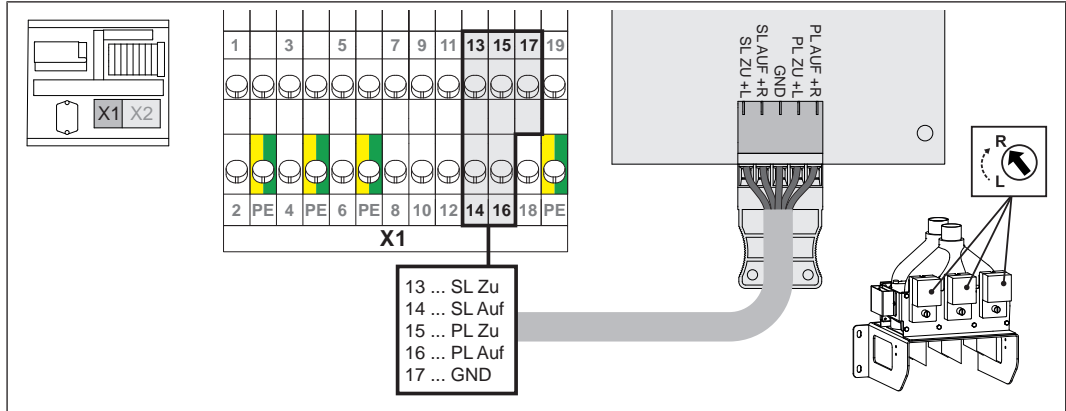
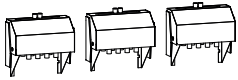

- Establish a connection line from the distributor box to the circuit board on the suction module
 - ↳ Connecting cable 5 x 0.75 mm² without earth conductor
- Set the direction of rotation of the servo-motor to right (R)

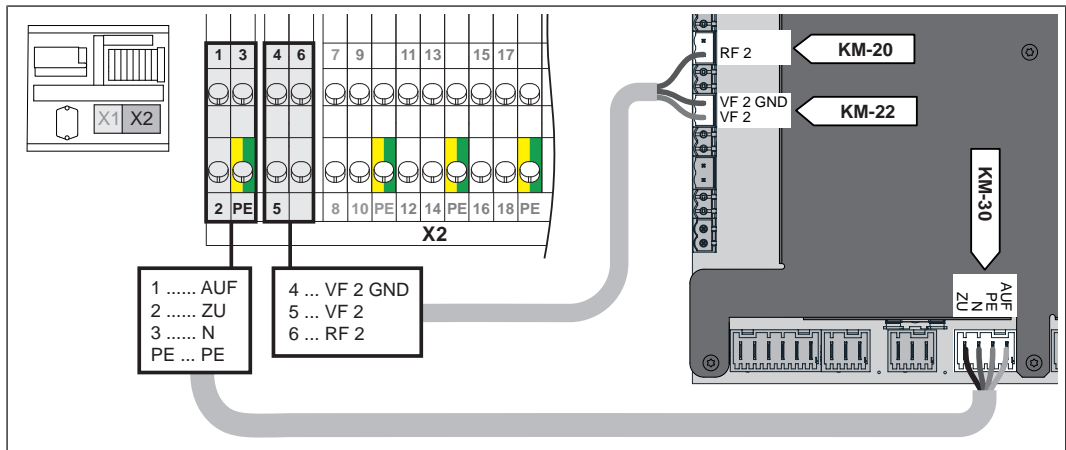

- Install the connection line for the motor control and position control from the distributor box to the core module inside the boiler controller
 - ↳ Connecting cable 4 x 0.75 mm² with earth conductor, max. 0.15kW / 230V
 - ↳ Connecting cable 3 x 0.75 mm² without earth conductor, screened if longer than 25 m

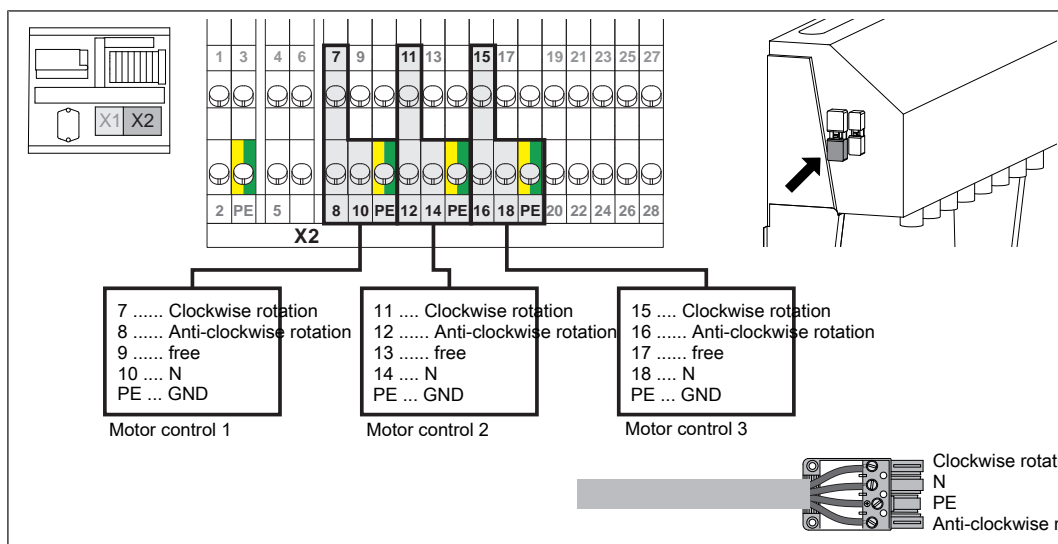

□ Attach the connection line for the motor control from the distributor box to the 4-pin plug of the change-over unit

↳ Connecting cable 4 x 0.75 mm² with earth conductor

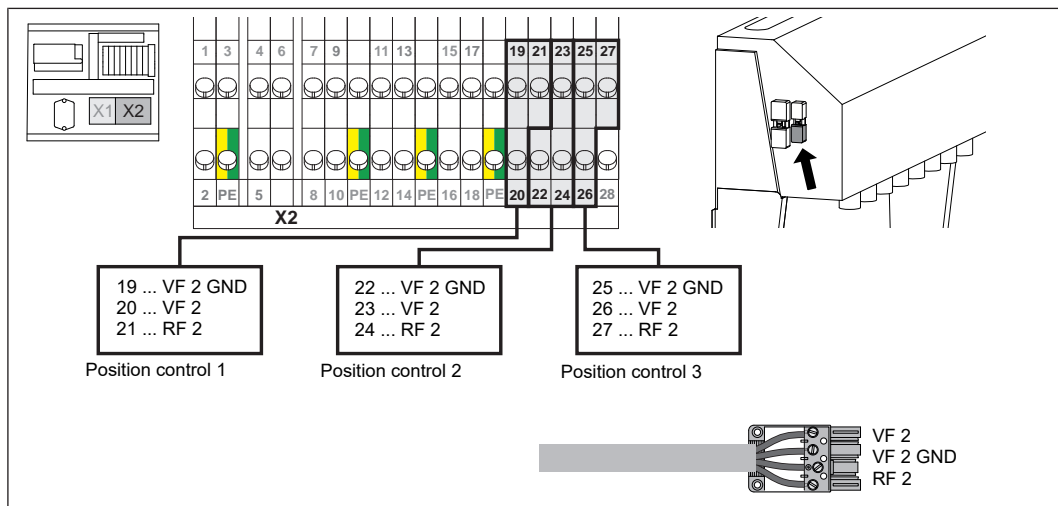

□ Attach the connection line for the position control from the distributor box to the 3-pin plug of the change-over unit

↳ Connecting cable 3 x 0.75 mm² without earth conductor

6.5.6 Mains connection

200-250 kW:

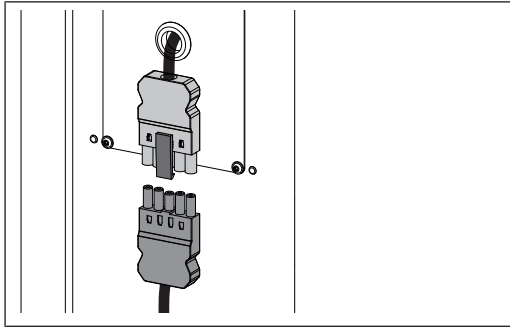

At the back of the boiler:

- Release the locking mechanism and pull the mains plug down and out
- Open the plug and connect the mains connection cable
 - ↳ Flexible sheathed cable must be used for the wiring; this must be of the correct size to comply with applicable regional standards and regulations.
 - ↳ The power supply line (mains connection) must be fitted with a C16 A fuse by the customer.

300-350 kW:

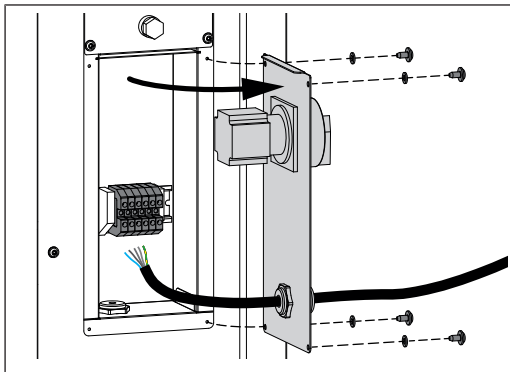

- Remove the cover plate along with the main switch from the back of the boiler
- Run the mains connection cable through the cable gland in the cover plate and connect it to the terminal blocks
 - ↳ Flexible sheathed cable must be used for the wiring; this must be of the correct size to comply with applicable regional standards and regulations.
 - ↳ The power supply line (mains connection) must be fitted with a C25A fuse by the customer.

6.5.7 Potential equalisation

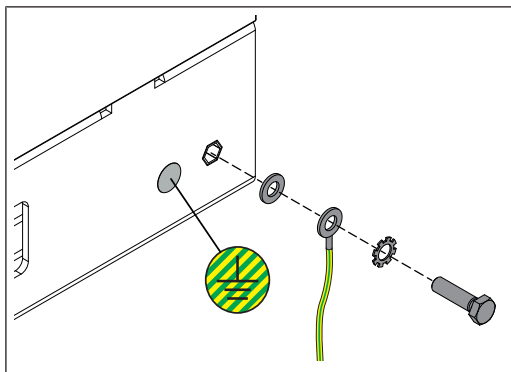

- ❑ The potential equalisation on the boiler base must comply with current directives, regulations and standards.

6.6 Final installation steps

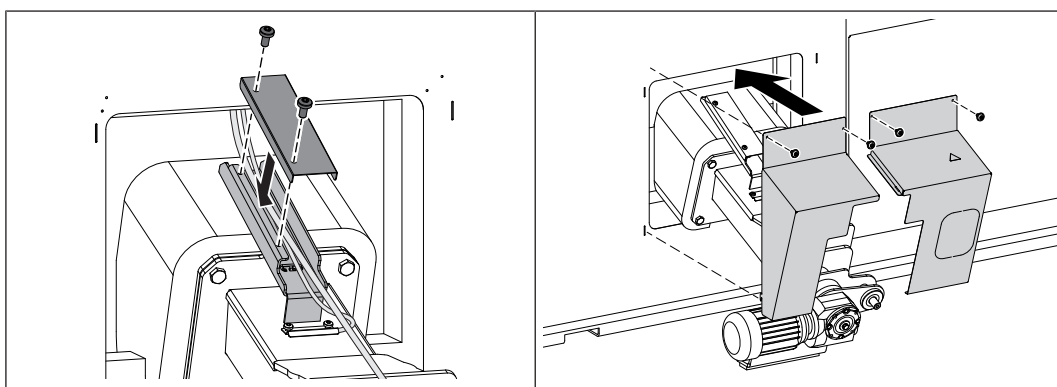

- ❑ Install the cover on the cable duct
 - ↪ Ensure that the cables do not touch the hot boiler components
- ❑ Fit the covers to the side panel of the boiler and secure them
 - 4x M4 x 10 raised-head screws

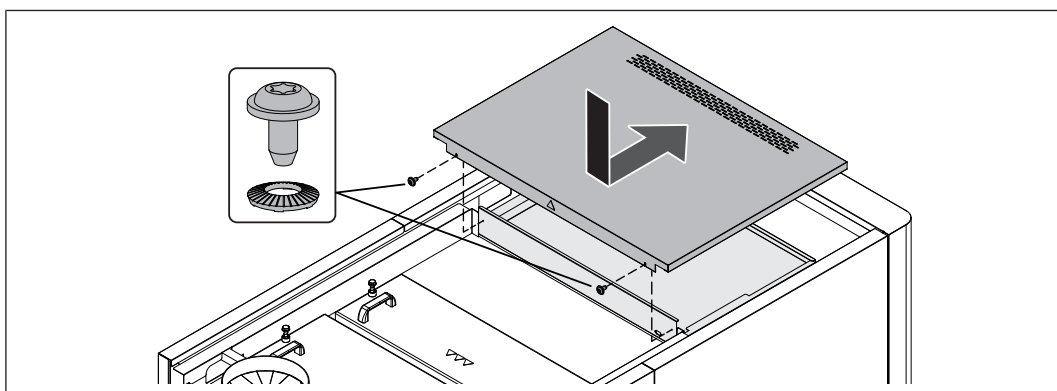

- ❑ Place the controller cover on the controller box and slide forward
- ❑ Attach the controller cover with retaining screw and contact washers

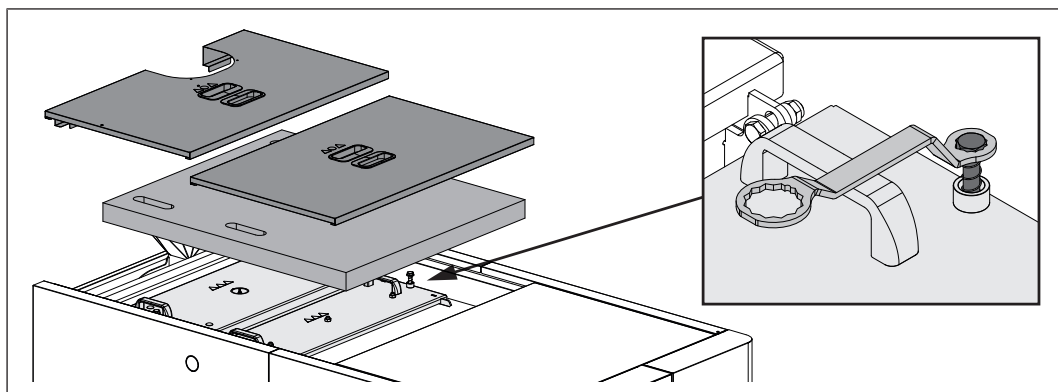

- Replace the heat exchanger and secure it with the screws
- Put on the insulating cover and thermal insulation
 - ↳ 200-250 kW: two insulating covers
 - ↳ 300-350 kW: three insulating covers

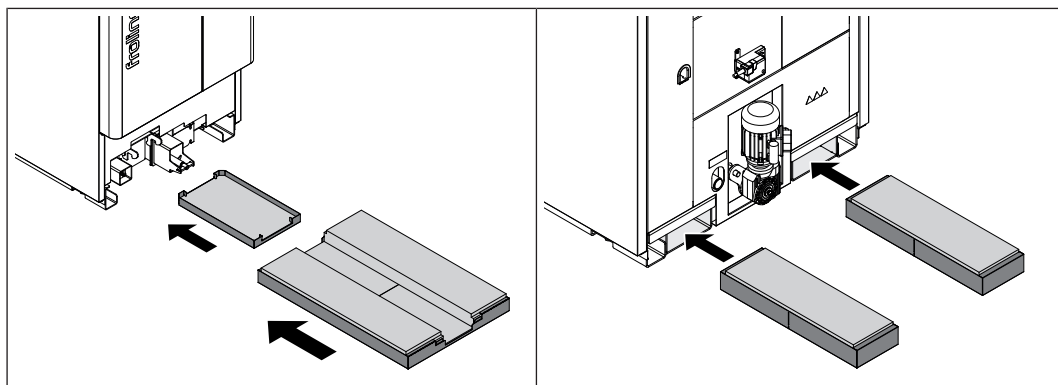

- Slide the floor insulation underneath the boiler from the front and back as shown

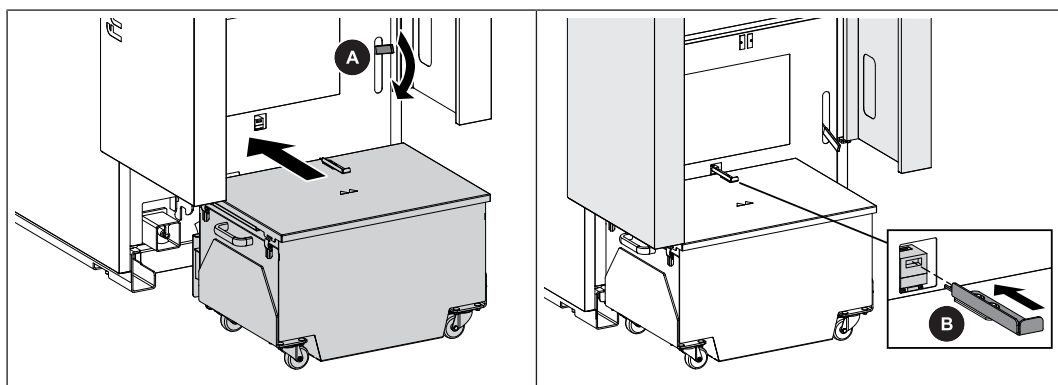

- Slide the ash container onto the ash duct and secure with the locking lever (A)
- Slide the key plate (B) into the safety limit switch and close both insulated doors

The safety limit switch can be adapted to the ash container as necessary:

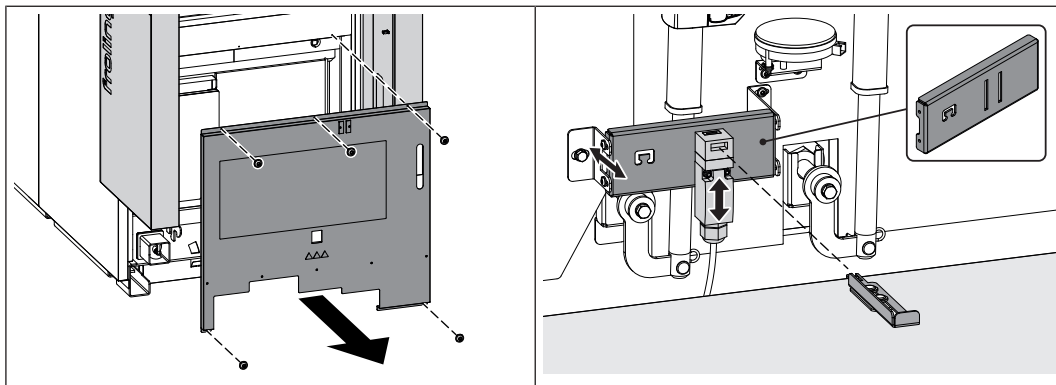

- Open the insulated door and remove the cover plate behind
- Slide the ash container onto the ash duct and secure with the locking lever
- Adapt the height and distance of the safety limit switch to the key plate on the ash container

6.6.1 Insulate the connection line

When using the optionally available thermal insulation supplied by Fröling GesmbH, perform the following steps:

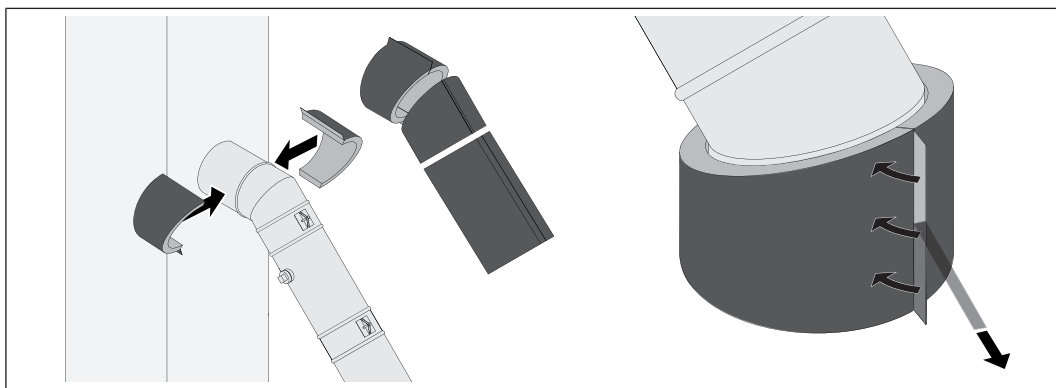

- Cut the half shells of thermal insulation to length and lay them on the connection line
- Create an opening for access to the measuring port
- Apply protective foil at the projecting lugs
- Glue the half shells to each other

6.6.2 Install the brackets for accessories

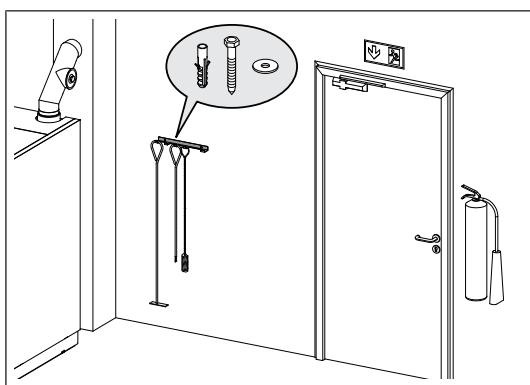

- Using appropriate fasteners, attach the brackets to the wall on the boiler
- Attach the accessories to the brackets

6.6.3 Affixing the identification plate

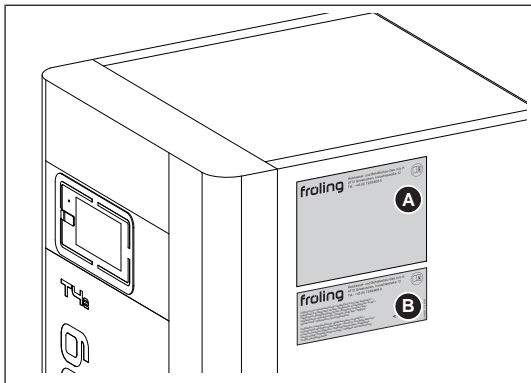

- Glue the supplied identification plate (A) and additional identification plate (B - for electrostatic particle separator) visibly to the right-hand side panel of the boiler

7 Start-up

7.1 Before commissioning / configuring the boiler

The boiler must be configured to the heating system during initial start-up!

IMPORTANT

Optimum efficiency and efficient, low-emission operation can only be guaranteed if the system is set up by trained professionals and the standard factory settings are observed.

Take the following precautions:

- Initial startup should be carried out with an authorised installer or with Froling customer services

IMPORTANT

Foreign bodies in the heating system impair its operational safety and can result in damage to property.

As a result:

- The whole system should be rinsed out before initial start-up in accordance with EN 14336.
- Recommendation: Make sure the hose diameter of the flush nozzles in the flow and return complies with ÖNORM H 5195 and is the same as the hose diameter in the heating system, however not more than DN 50.

- Switch on the main switch and configure the boiler controller to the type of system
- Check the system pressure of the heating system
- Check that the heating system is fully ventilated
- Check all quick vent valves of the entire heating system for leaks
- Check that all screw connections at water-bearing joints are tightly sealed
 - ↳ Pay particular attention to those connections from which plugs were removed during assembly
- Check the entire hydraulic pipework for leaks
- Check the entire return temperature control for leaks and correct function
- Check that all necessary safety devices are in place
- Check that there is sufficient ventilation in the boiler room
- Check the leaktightness of the boiler
 - ↳ All doors and inspection openings must be tightly sealed!
- Check that the drives and servo-motors are working and turning in the right direction
- Check safety switch of ash box is working correctly

IMPORTANT! Check the digital and analogue inputs and outputs - See the operating instructions for the boiler controller!

7.2 Initial startup

7.2.1 Permitted fuels

Wood pellets

Wood pellets made from natural wood with a diameter of 6 mm

Note on standards

EU:	Fuel acc. to EN ISO 17225 - Part 2: Wood pellets class A1 / D06
and/or:	ENplus / DINplus certification scheme

General note:

Before refilling the store, check for pellet dust and clean if necessary.

7.2.2 Non-permitted fuels

The use of fuels other than those defined in the "Permitted fuels" section, and particularly the burning of refuse, is not permitted

IMPORTANT

In the event that non-permitted fuels are used:

Burning non-permitted fuels increases the amount of cleaning required and leads to a build-up of aggressive deposits and condensation which can damage the boiler. Consequently this invalidates the warranty! Using non-standard fuels can also lead to serious faults in combustion!

For this reason, when operating the boiler:

- Use only the permitted fuels

8 Decommissioning

8.1 Mothballing

The following measures should be taken if the boiler is to remain out of service for several weeks (e.g. during the summer):

- Clean the boiler thoroughly and close the doors fully

If the boiler is to remain out of service during the winter:

- Have the system completely drained by a qualified technician
 - ↳ Protection against frost

8.2 Disassembly

To disassemble the system, follow the steps for assembly in reverse order.

8.3 Disposal

- Ensure that they are disposed of in an environmentally friendly way in accordance with waste management regulations in the country (e.g. AWG in Austria)
- You can separate and clean recyclable materials and send them to a recycling centre.
- The combustion chamber must be disposed of as builders' waste.

Manufacturer's address

Fröling Heizkessel- und Behälterbau GesmbH

Industriestraße 12
A-4710 Grieskirchen
+43 (0) 7248 606 0
info@froeling.com

Zweigniederlassung Aschheim

Max-Planck-Straße 6
85609 Aschheim
+49 (0) 89 927 926 0
info@froeling.com

Froling srl

Via J. Ressel 2H
I-39100 Bolzano (BZ)
+39 (0) 471 060460
info@froeling.it

Froling SARL

1, rue Kellermann
F-67450 Mundolsheim
+33 (0) 388 193 269
froling@froeling.com

Installer's address

Stamp

Froling customer services

Austria
Germany
Worldwide

0043 (0) 7248 606 7000
0049 (0) 89 927 926 400
0043 (0) 7248 606 0



www.froeling.com

froling 