



ENG

Technical instructions

for installation and using the additional equipment

CM2K module for
mixing circuits / DHW / Recirculation

for connection to: PelTec II Lambda, PelTec-Compact,
BIO-SC, ZVB II, PelTec, Cm Pelet-set Touch, BioTec-L, BioTec Plus,
EKO-CKS P Unit, EKO-CKS Multi Plus

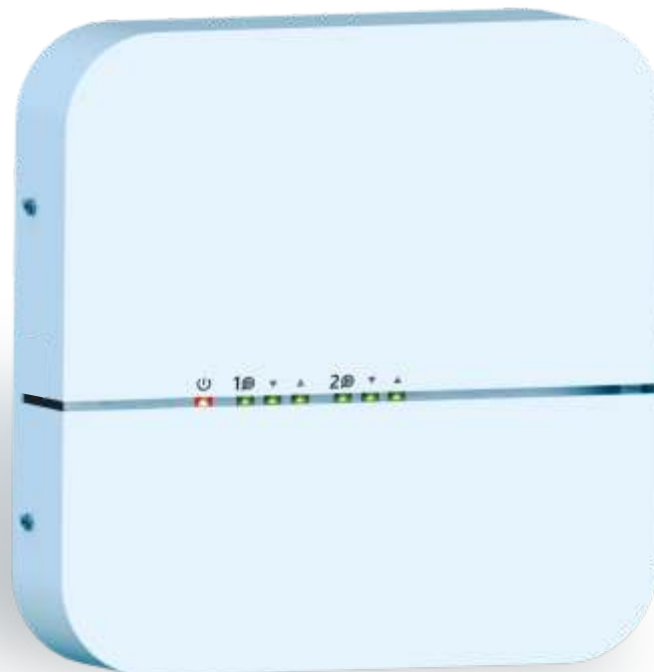

CM2K

Thank you for purchasing our product

Please read these technical instructions carefully so that you can use and adjust the CM2K module as easily as possible. After reading the instructions, place them in an appropriate place where you can easily find them if you need further information about the operation and use of the CM2K module.

Please make sure that the CM2K module has been disposed of in order to reduce environmental pollution.

CONTENT

CM2K TECHNICAL CHARACTERISTICS	3
BASIC PARTS	3
1.0. CM2K DELIVERY CONTENT	4
1.1. ADDITIONAL EQUIPMENT FOR CM2K	4
1.2. CM2K MODULE INSTALLATION	4
1.3. CONNECTION TO THE BOILER	5
1.4. CONNECTING MORE CM2K MODULES	9
1.5. CONNECTION TO THE OTHER DEVICES	10
1.6. INPUTS AND OUTPUTS CONNECTION	11
2.0. LED INDICATORS	12
3.0. CONFIGURATIONS	13
4.0. SELECTING THE NUMBER OF CM2K MODULES	15
5.0. CM2K CIRCUITS CONFIGURING	18
6.0. MANUAL TEST	19
6.1. PelTec II Lambda / PelTec-Compact / BIO-SC / ZVB II	19
6.2. PelTec / Cm Pelet-set Touch / BioTec-L / BioTec Plus / EKO-CKS P Unit / EKO-CKS Multi Plus	20
7.0. CM2K VIEW	21
7.1. PelTec II Lambda / PelTec-Compact / BIO-SC / ZVB II	21
7.1.1. CM2K VIEW SELECTION	21
7.1.2. CIRCUIT TYPES	21
7.1.3. SYMBOLS ON THE "HEATING SCREEN"	23
7.2. PelTec / Cm Pelet-set Touch / BioTec-L / BioTec Plus / EKO-CKS P Unit / EKO-CKS Multi Plus	24
7.2.1. CM2K VIEW SELECTION	24
7.2.2. CIRCUIT TYPES	25
7.2.3. CM2K VIEW EXAMPLES	26
8.0. SETTING CM2K MODULE	27
8.1. PelTec II Lambda / PelTec-Compact / BIO-SC / ZVB II	27
8.2. PelTec / Cm Pelet-set Touch / BioTec-L / BioTec Plus / EKO-CKS P Unit / EKO-CKS Multi Plus	28
9.0. DESCRIPTION AND VALUES OF THE PARAMETERS BY HEATING CIRCUIT TYPE	29
9.1. PelTec II Lambda / PelTec-Compact / BIO-SC / ZVB II	29
9.1.1. RADIATORS / FLOOR	33
9.1.2. CONSTANT TEMPERATURE	33
9.1.3. DHC	34
9.1.4. DHW	34
9.1.5. DHW+REC	34
9.2. PelTec / Cm Pelet-set Touch / BioTec-L / BioTec Plus / EKO-CKS P Unit / EKO-CKS Multi Plus	36
9.2.1. RADIATOR / FLOOR	37
9.2.2. CONSTANT TEMPERATURE	40
9.2.3. DHW	40
9.2.4. RECIRCULATION	40
9.2.5. DHW+RECIRCULATION	42

CM2K TECHNICAL CHARACTERISTICS

Inputs	4x sensor inputs (NTC5K, 2x main flow/DHW, 1x outdoor, 1x reserve)
	2x room corrector inputs CSK
	2x digital inputs (CSK-Touch: wire)
	1x power supply 12VDC
Outputs	4x semi-conductor (triac / 2x pump, 2x mixing valve actuator)
Output power	Triacs (2x) max. 200W (1A)
Power supply	195-265V/50Hz
Max. power	
Electricity consumption	
Conductor cross section	1-1,5 mm ²
IP protection	IP20 according EN
Environment temperature	-10 do 40°C
CM2K mass	715 g
Housing material	Flame resistant ABS (UL94V-0)
CM2K dimensions	(WxHxD) 200x40x200

Sensor technical characteristics

Sensor type	NTC5K
Min. conductor cross section	0,5-0,75 mm ²
Max. conductor length	50 m

EC Declaration

The product complies with the requirements of the current rules and is marked CE.
The EC Declaration of Conformity is available on request, contact the manufacturer.



BASIC PARTS

INPUTS:

- 4x sensor input (NTC5K sensor - 2x main flow/DHW, 1x outdoor sensor, 1x reserve)
- 2x room corrector CSK input (possibility of connection with 3 or 2 wires - connection depends of boiler type and boiler firmware)
- 2x digital input (CSK-Touch: wire)
- 1x 12VDC

OUTPUTS:

- 2x standard (230V) - pump
- 2x standard (230V) - actuator
- 2x UTP connector for connecting to the boiler and connection more CM2K modules or other additional equipment (WiFi box...)

DELIVERY in cardboard box:

- 1x CM2K module
- 2x NTC5K (main flow sensor / DHW sensor)
- 1x UTP cable 5m
- 3x dowel+screw
- 10x cable ties
- 1x technical instructions

1.0. CM2K DELIVERY CONTENT

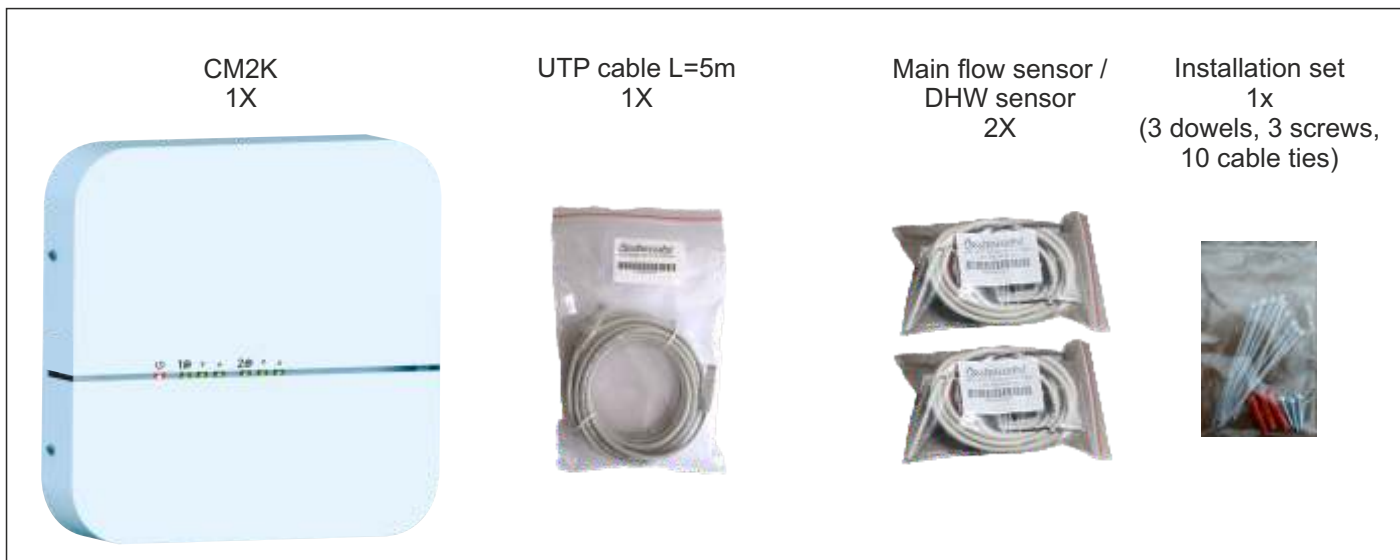

1.1. ADDITIONAL EQUIPMENT FOR CM2K

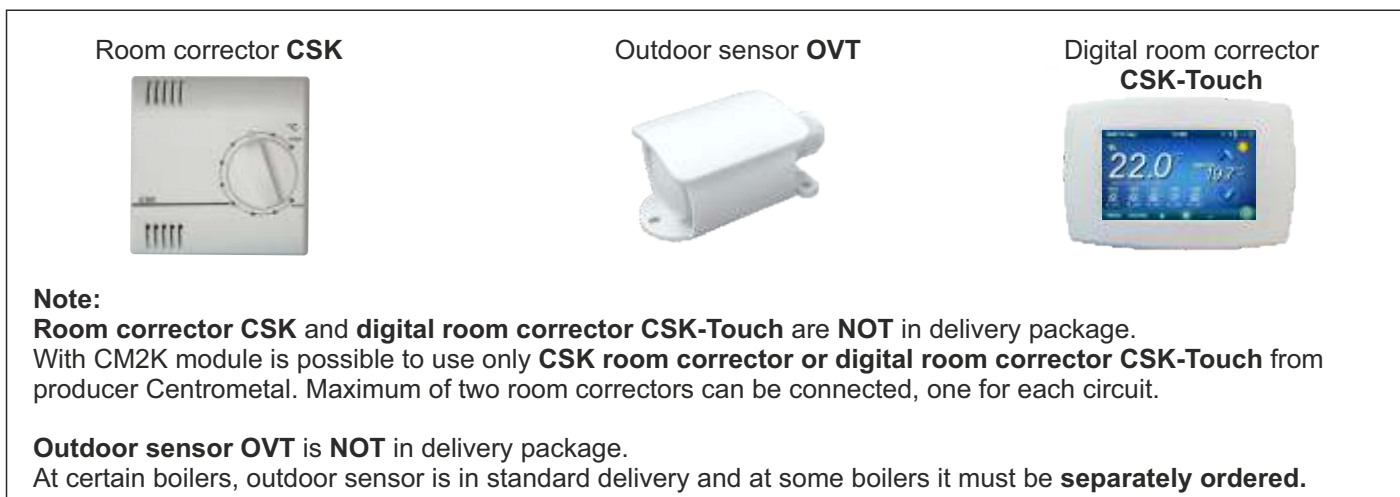

1.2. CM2K MODULE INSTALLATION

CM2K module is installed on the wall or on hard surface in closed dry room.
 According the picture below, drill 3 holes 6 mm x 35-40 mm.
 Insert 3 dowels into drilled holes and install screw into upper dowel with ca. 4 mm distance from the wall.

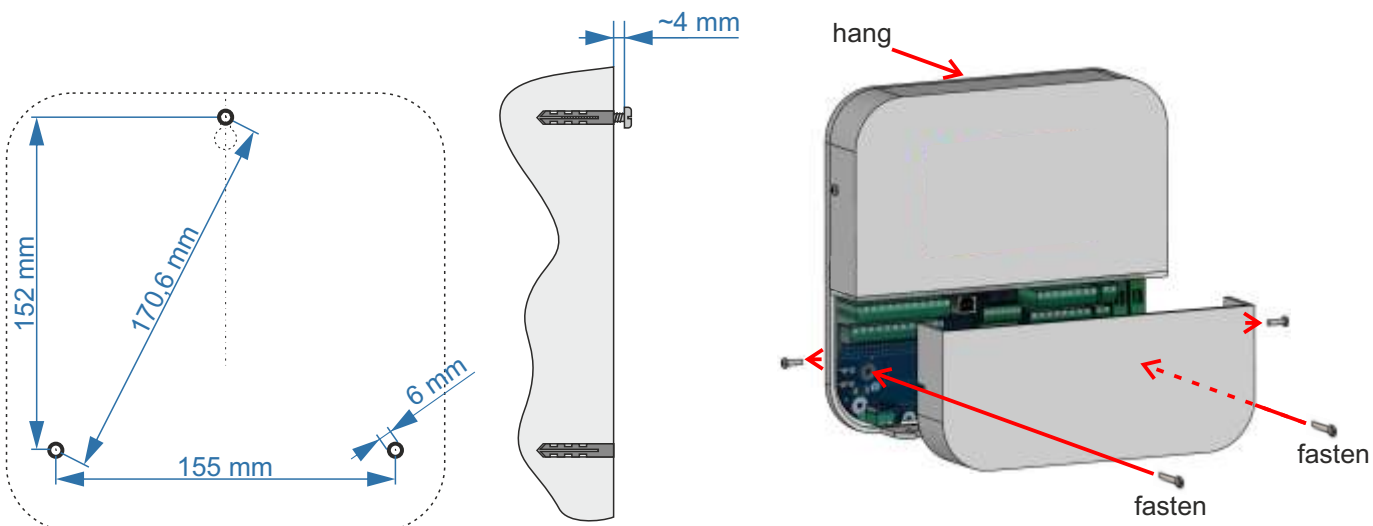

Remove lower cover, hang the module on the upper screw, install lower screws to the mounting holes in the module and in the wall. Fasten the screws to secure the module to the wall.

1.3. CONNECTION TO THE BOILER

Boiler type: PeITec II Lambda / BIO-SC / PeITec II HERMETIC

Lambda board: LC-21-GS V1 (22995XXXXXX "G")

CM2K

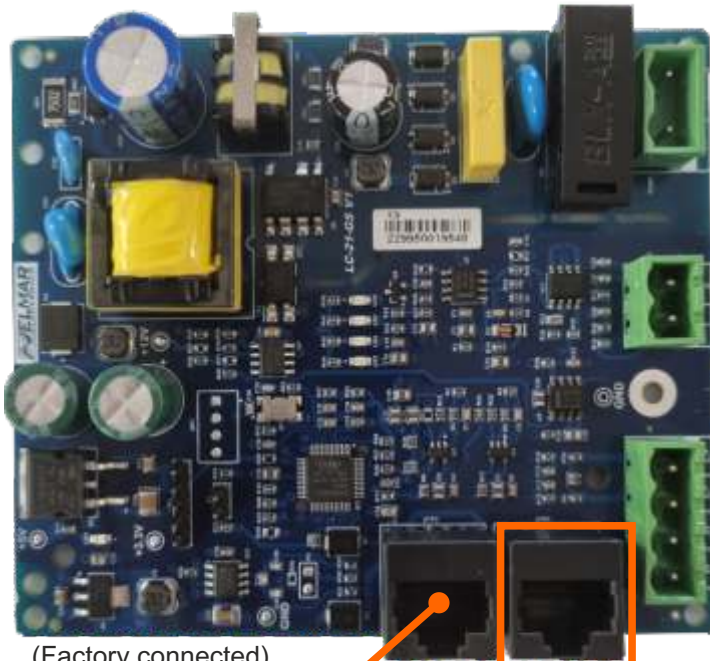

(Factory connected)
place to connect
UniDrive PCB



UTP

NOTE FOR LAMBDA - BOARD:

Two UTP connectors on the Lambda - board have the same function and are used to connect to the UniDrive PCB or to the additional equipment.

NOTE FOR CM2K:

Two UTP connectors on the CM2K module have the same function and are used to connect to the boiler (Lambda - board) or to the additional equipment.

Boiler type: PeITec-Compact

CM2K

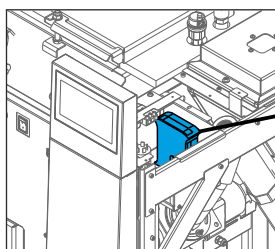

module - CVT

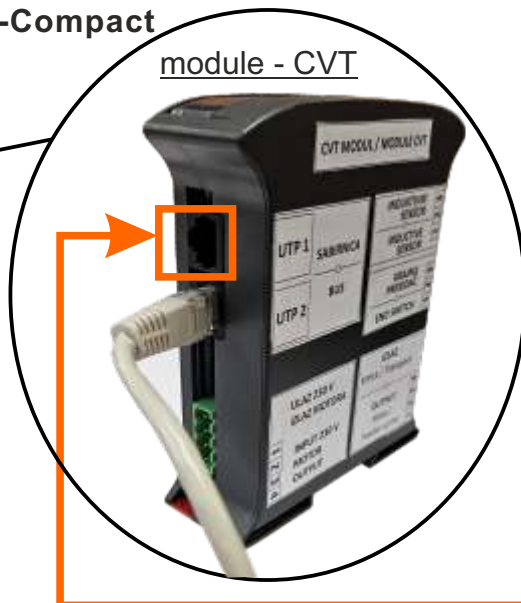

UTP



NOTE FOR MODULE - CVT FOR CONTROL OF THE VACUUM SUCTION SYSTEM:

Two UTP connectors on the MODULE-CVT for control of the Vacuum suction system have the same function and are used to connect to the AddOnDrive PCB or to the additional equipment.

NOTE FOR CM2K:

Two UTP connectors on the CM2K module have the same function and are used to connect to the suction system module or to the additional equipment.

Boiler type: ZVB II

CM2K



Boiler type: PelTec

CM2K

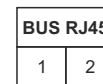
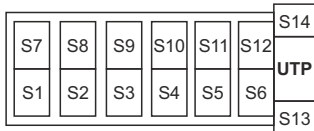

UTP

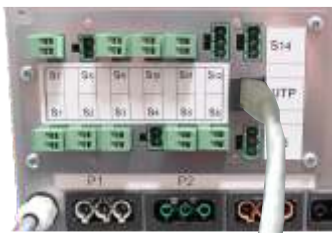

NOTE:

both UTP connectors in CM2K have same function and are used for connection to the boiler or connection of other additional equipment

UTP

Boiler type: BioTec-L

CM2K

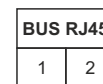
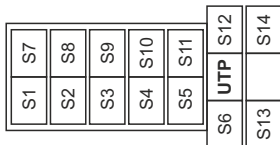

UTP



UTP

Boiler type: Cm Pelet-set Touch

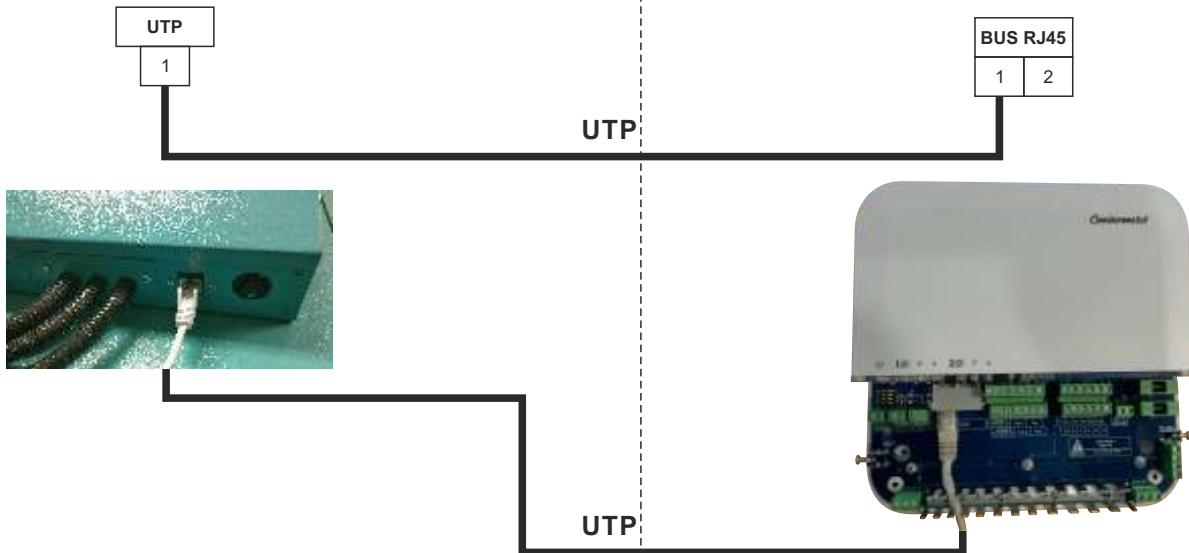

Boiler type: BioTec Plus

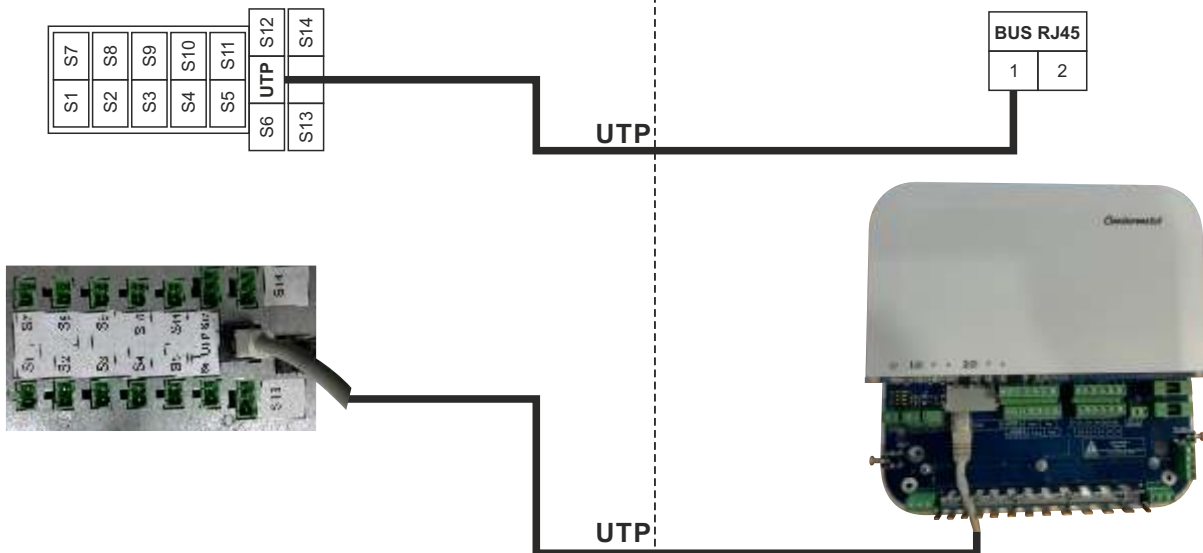

Boiler type: EKO-CKS P Unit

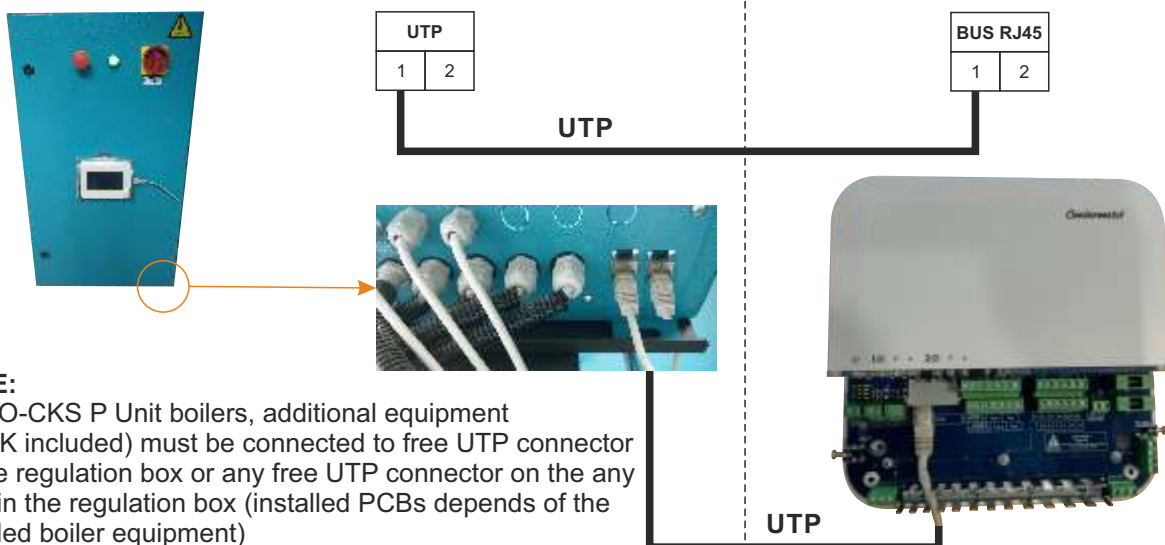

NOTE:
in EKO-CKS P Unit boilers, additional equipment (CM2K included) must be connected to free UTP connector on the regulation box or any free UTP connector on the any PCB in the regulation box (installed PCBs depends of the installed boiler equipment)

Boiler type: EKO-CKS Multi Plus

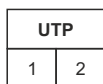

UTP



NOTE:
in EKO-CKS Multi Plus boilers, additional equipment (CM2K included) must be connected to free UTP connector on the regulation box or any free UTP connector on the any PCB in the regulation box (installed PCBs depends of the installed boiler equipment)

CM2K

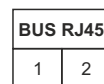







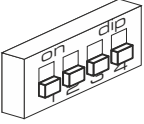

UTP

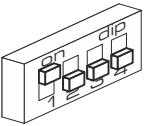
1.4. CONNECTING MORE CM2K MODULES

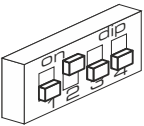
Maximum up to 4 modules can be connected. Connection is done by UTP cables. UTP input/output 1 or UTP input/output 2 can be used (they both have same function, free connector is used for connection of next module or for connection of other additional equipment).

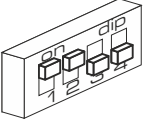
If there are more than 1 CM2K installed, in every module is necessary to set device address (0-4). Address is set by SW switches on the PCB of the module (below casing cover of the connection clamps). Order of connection is not important, circuit number is defined by module address with SW switches (every module must have different address, i.e. two devices can't have same address).

 <p>Position of the SW switches</p>	<p>Device 1</p> <p>1 - off 2 - off 3 - off 4 - off</p>  
	<p>Device 2</p> <p>1 - on 2 - off 3 - off 4 - off</p>  
	<p>Device 3</p> <p>1 - off 2 - on 3 - off 4 - off</p>  
	<p>Device 4</p> <p>1 - on 2 - on 3 - off 4 - off</p>  

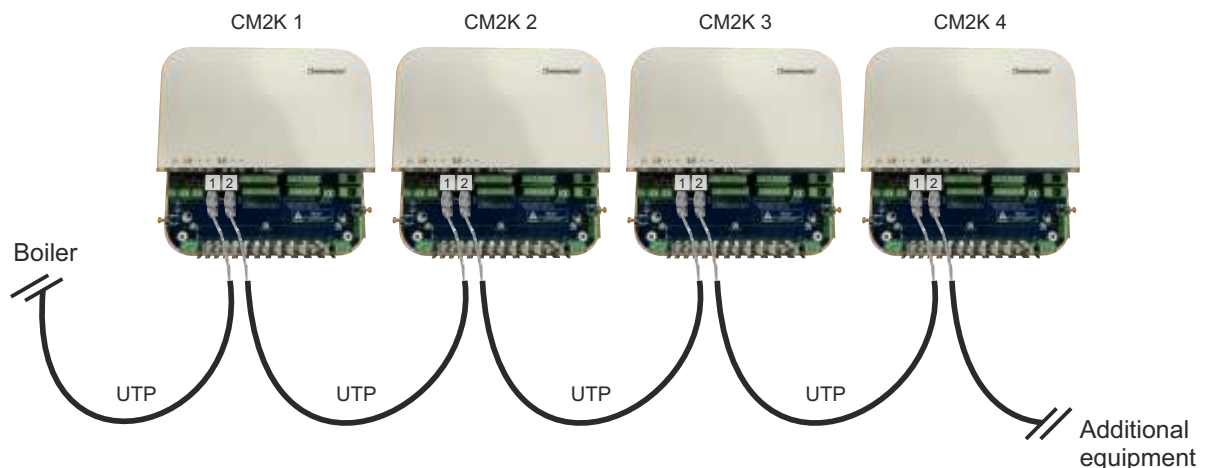

1.5. CONNECTION TO THE OTHER DEVICES (CM WIFI-BOX, CM-GSM, CMNET, CVT)

Connection is done with UTP cables. Every additional equipment device has 2 UTP connectors. Both UTP connector have same function. Devices can be connected in any order.

Example of connection:

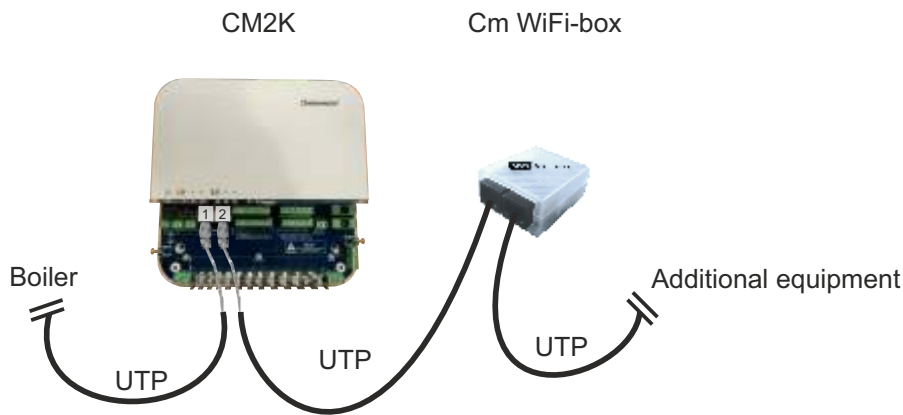
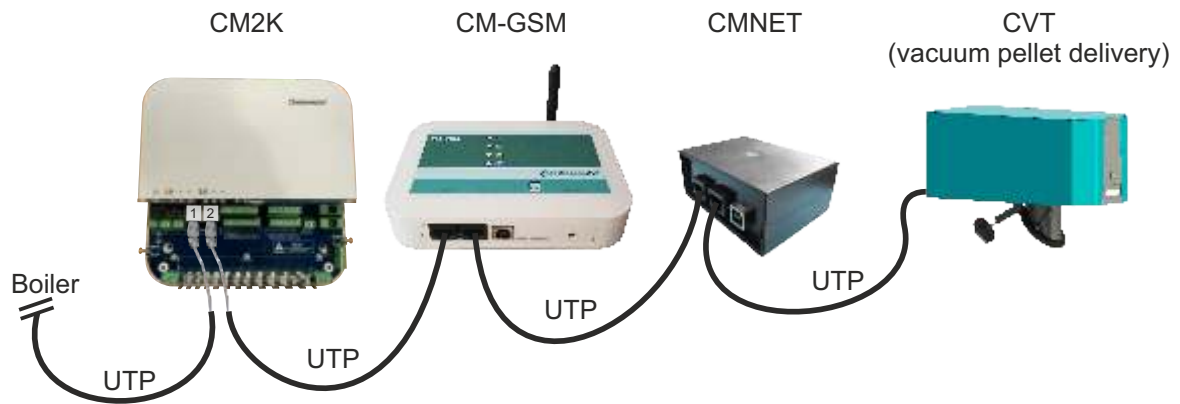

1.6. INPUTS AND OUTPUTS CONNECTION



Digital input

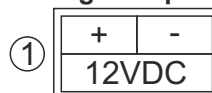

Digital inputs/outputs



1 - Input (12V DC):

CSK-Touch digital room corrector uses power supply via input / output D.COR when the boiler main switch is ON.

OPTION - input (12V DC): can be used to power CSK-Touch digital room corrector when the boiler main switch is OFF (additional equipment: 12V DC rectifier)

1a - Digital inputs/outputs:

Wired connection of CSK-Touch digital room corrector. It is not important which output each individual corrector is connected to, but pay attention to have the corrector terminal "+" connected to the CM2K terminal "+" and vice versa, to have the corrector terminal "-" connected to the CM2K terminal "-".

UTP inputs/outputs

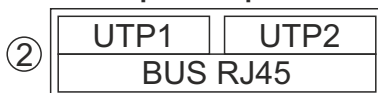

Inputs/outputs for UTP cables

- one input/output is for connection to the boiler
- free input/output is used for connecting more CM2K modules or other additional equipment

Circuit 1 inputs



Circuit 1 inputs

- A.COR 1 - room corrector CSK (3 wires: 1, 2, 3) / (2 wires: 2, 3)
- room thermostat/reg. control (1, 2)
- Tsp 1 - main flow sensor
- Tos - outdoor sensor

Circuit 2 inputs



Circuit 2 inputs

- A.COR 2 - room corrector CSK (3 wires: 1, 2, 3) / (2 wires: 2, 3)
- room thermostat/reg. control (1, 2)
- Tsp 2 - main flow sensor
- Tspr - reserve (not used)

Triac outputs (230 V)

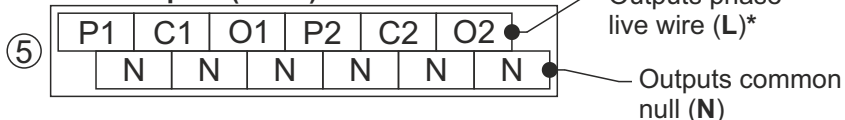

- *P1 - Circuit 1 pump / DHW pump 1
- C1 - Circuit 1 actuator - close
- O1 - Circuit 1 actuator - open / Recirculation pump 1
- P2 - Circuit 2 pump / DHW pump 2
- C2 - Circuit 2 actuator - close
- O2 - Circuit 2 actuator - open / Recirculation pump 2

NOTE:

The maximum current for each pump output is $I_{max} = 1 A$

In case of installation of a stronger or three-phase pump, it is necessary to install an additional contactor.

Power supply

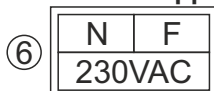

CM2K power supply

power supply 230V must be connected to control connected pumps and actuators

Earthing

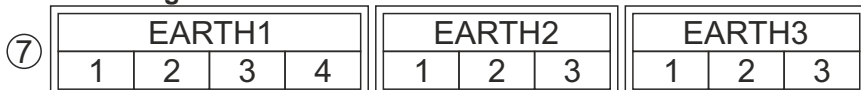

Common earthing

connect earthing of the power supply and connected pumps





⑧ **Cable connection rail**
fasten the cables to the rail with cable ties

⑨ F2 - fuse 1,6A - outputs 2. circuit
(pump, actuator)

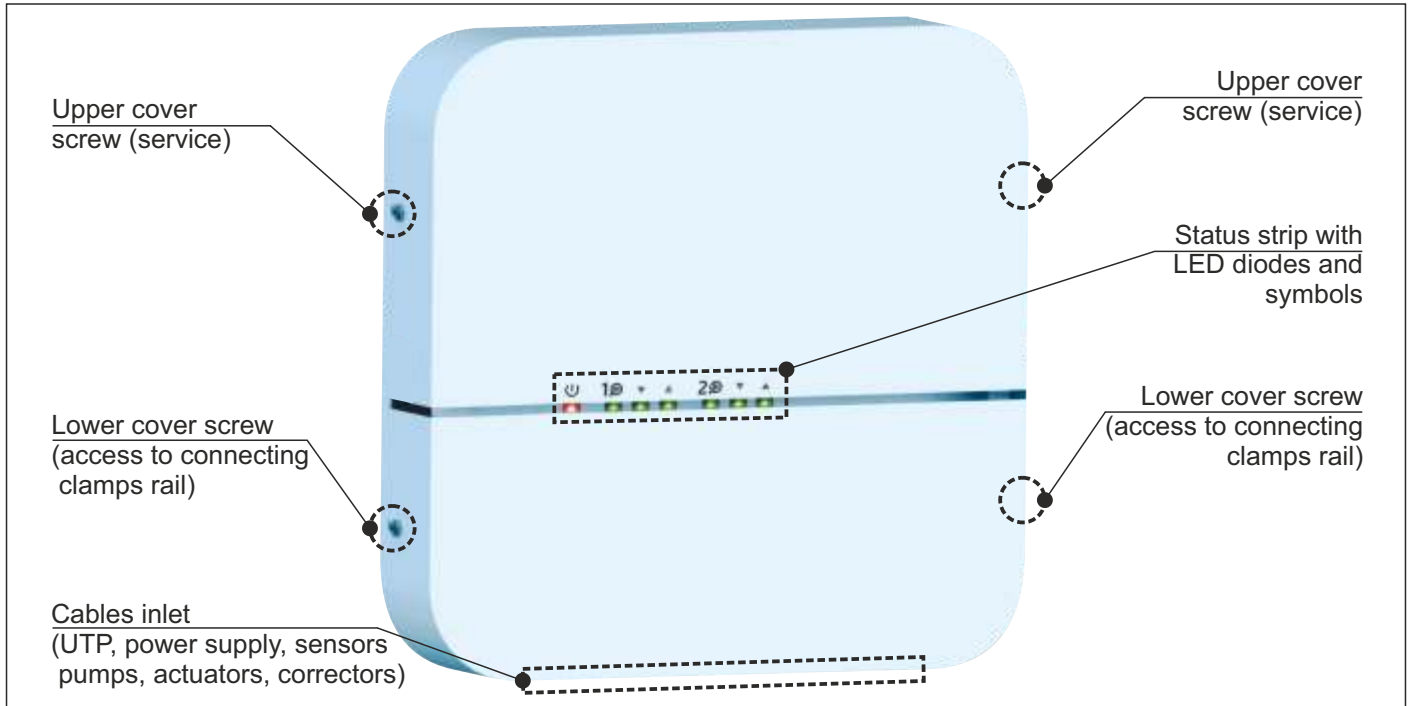
⑩ F1 - fuse 1,6A - outputs 1. circuit
(pump, actuator)

2.0. LED INDICATORS



-  - **status** - indicates CM2K status; connection with the boiler is ok, boiler is connected to the power supply and main switch is on - doesn't mean that CM2K is connected to the power supply (230V)
-  - **pump** - indicates working of the pump (LED ON = pump works / LED OFF = pump doesn't work)
-  - **actuator - close** (LED ON = actuator closes / LED OFF = actuator doesn't work)
-  - **actuator - open** (LED ON = actuator opens / LED OFF = actuator doesn't work)

NOTE: actuator open and actuator close can't work at the same time

EXAMPLES OF LED INDICATORS



1. Circuit
All devices are off



2. Circuit
All devices are off



1. Circuit
Pump works; Mixing valve closes



2. Circuit
Pump works; Mixing valve closes



1. Circuit
Pump works; Mixing valve opens



2. Circuit
Pump works; Mixing valve opens

3.0. CONFIGURATIONS



PelTec II Lambda, PelTec-Compact, ZVB II: Configuration schemes you can find in the boiler's technical instructions, and the screen views in the technical instructions for the controller.



Peltec, BioTec-L, Cm Pelet-set Touch, BioTec Plus, EKO-CKS P Unit, EKO-CKS Multi Plus: Configuration schemes and the screen views you can find in the technical instructions for the controller.

Boiler configuration must be set in the **Installation** menu (under PIN) (only authorised technician can use it).

PelTec II Lambda / ZVB II / BIO-SC / PelTec - CM2K can be enabled only in configurations (schemes) that have accumulation (buffer) tank or hydraulic crossover.

BioTec-L - CM2K can be enabled in all configurations (schemes) because all have accumulation (buffer) tank.

Cm Pelet-set Touch - CM2K can be enabled in all configurations (schemes) because all have accumulation (buffer) tank, hydraulic crossover or 4-way mixing valve.

BioTec Plus - CM2K can be enabled in all configurations (schemes) because all have accumulation (buffer) tank.

EKO-CKS P Unit - CM2K can be enabled in all configurations (schemes) because all have accumulation (buffer) tank or hydraulic crossover.

EKO-CKS Multi Plus - CM2K can be enabled in all configurations (schemes) because all have accumulation (buffer) tank.

Example of configuration (scheme) selecting: PelTec II Lambda/PelTec-Compact/ BIO-SC/ZVB II

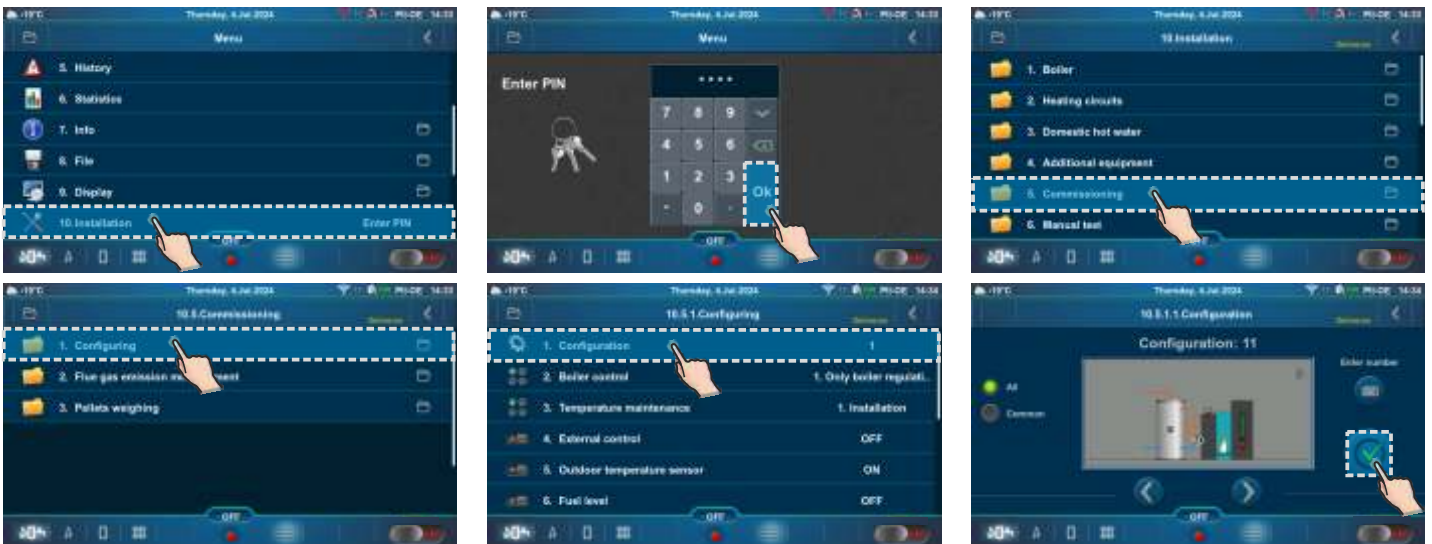

Example of configuration (scheme) selecting: **PeITec**

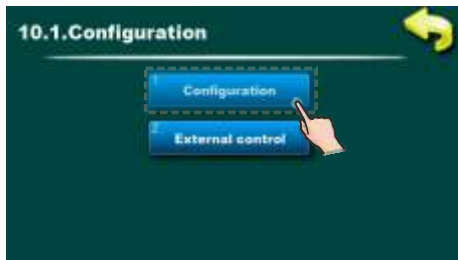

4.0. SELECTING THE NUMBER OF CM2K MODULES



Display order and ordinal numbers in regulation don't have to match exactly to this instructions. They depend of the configuration, firmware version and setting of the regulation.

CM2K can only be enabled on by an authorized service technician in the Installation menu (PIN). CM2K regulator is activated when the number of CM2K modules is selected (every module can control 2 circuits).

NOTE: after enabling any of CM2K modules (2 circuits), it is necessary to select heating type for each circuit. After that, circuit is activated and settings for it will be displayed.

Example of CM2K module selection: **PelTec II Lambda / PelTec-Compact / BIO-SC / ZVB II (1xCM2K - 2 circuits)**

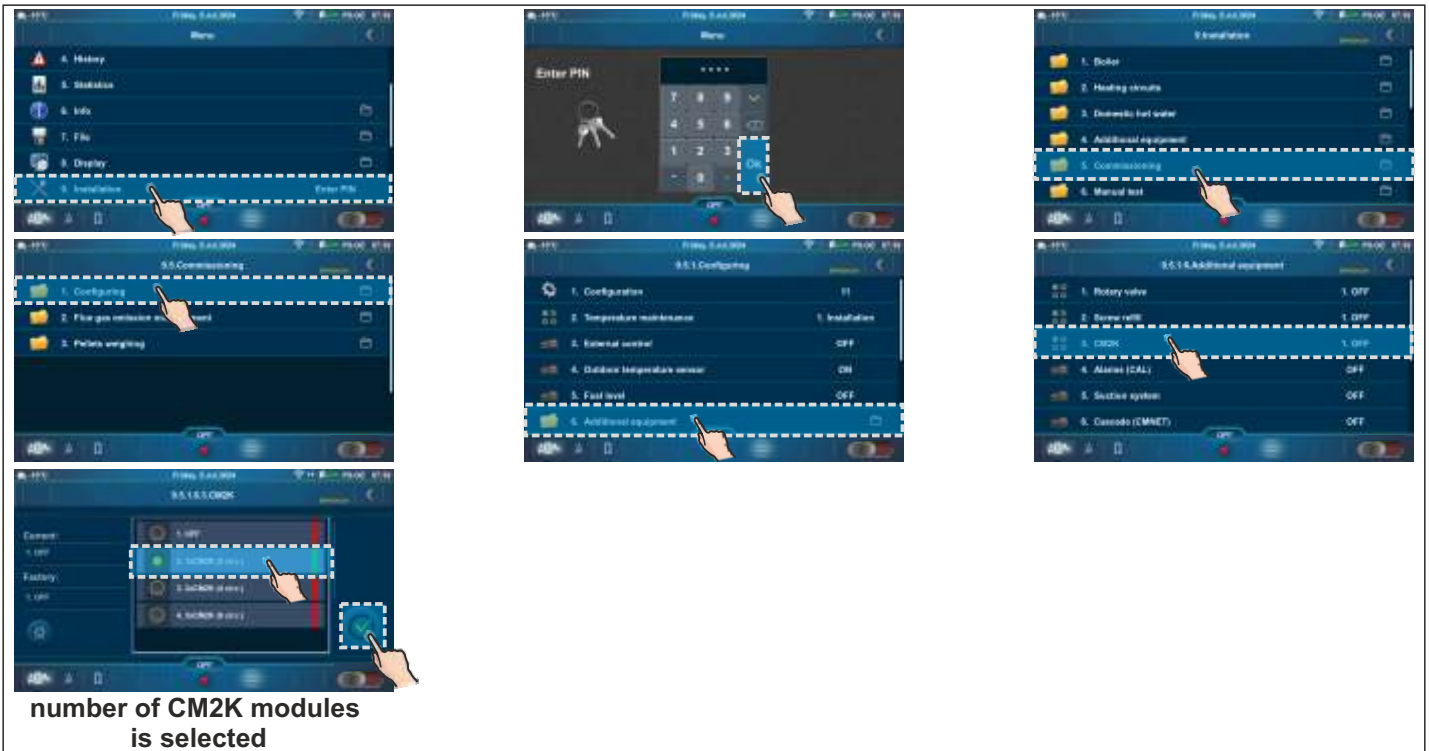

By selecting number of CM2K modules, option REGULATOR / CM2K is enabled (activated) and in the main menu Regulator/CM2K menu icon will be displayed. User can use this menu to monitor and adjust some of the parameters.

Example of CM2K module selection: **PelTec (1xCM2K - 2 circuits)**



Example of CM2K module selection: **BioTec-L (2xCM2K - 4 circuits)**



Example of CM2K module selection: **Cm Pelet-set Touch (1xCM2K - 2 circuits)**

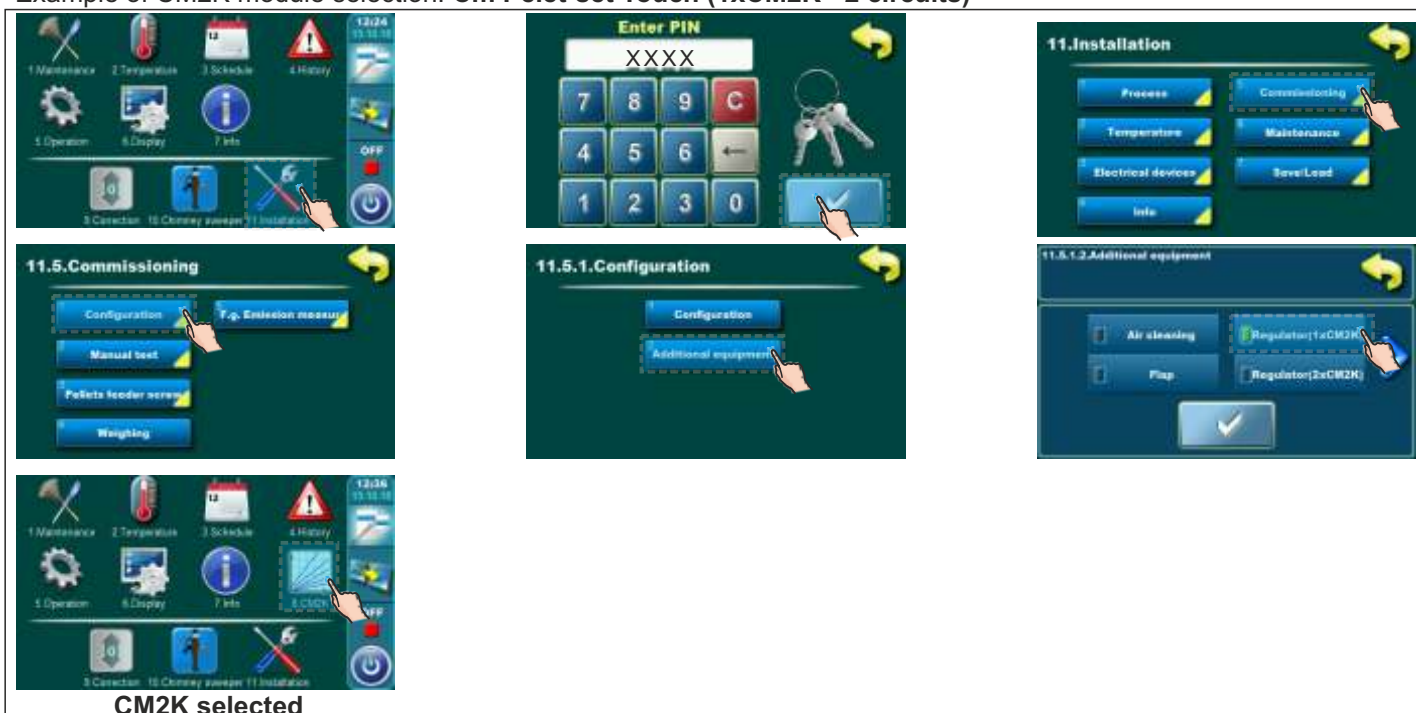

Example of CM2K module selection: **BioTec Plus (1xCM2K - 2 circuits)**



Example of CM2K module selection: EKO-CKS P Unit (1xCM2K - 2 circuits)

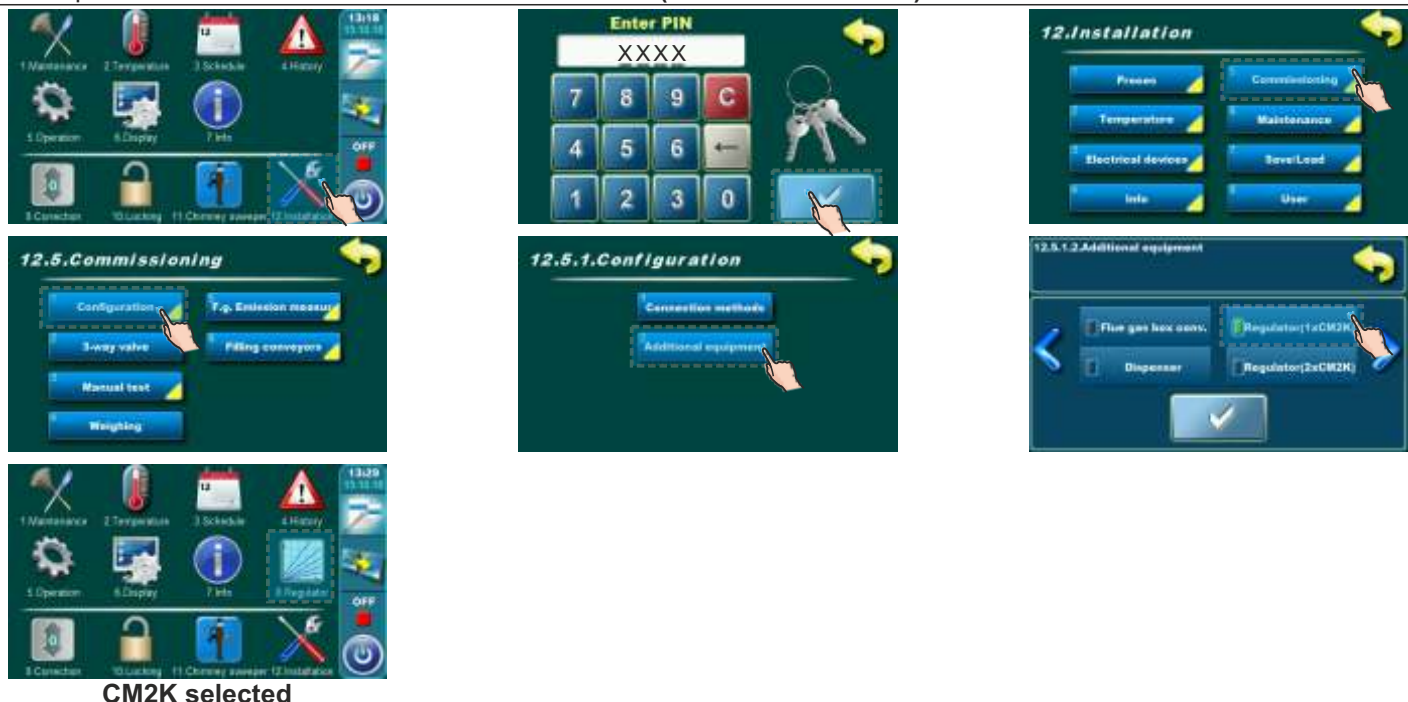

Example of CM2K module selection: EKO-CKS Multi Plus (1xCM2K - 2 circuits)



5.0. CM2K CIRCUITS CONFIGURING

After selecting the number of CM2K module, it is necessary to configure the CM2K circuits, i.e. select the heating type for each circuit (configured by an authorized service technician in the **Installation menu (PIN)**). After that, submenus of Heating circuits (CX) Circ Y will appear in the main menu under "Heating circuits" and/or "Domestic hot water" (in the submenus, the user can activate or deactivate heating circuits and adjust certain parameters).

Example of CM2K configuring: **PeITec II Lambda, PeITec-Compact, ZVB II, BIO-SC (1xCM2K - 2 circuits)**
(the same principle applies to other boilers)

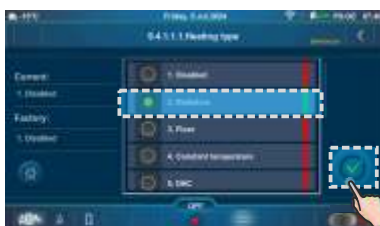
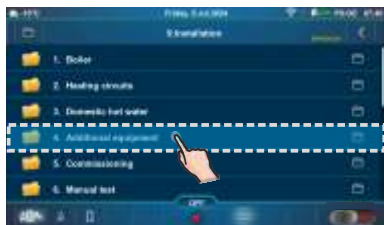

heating type is selected

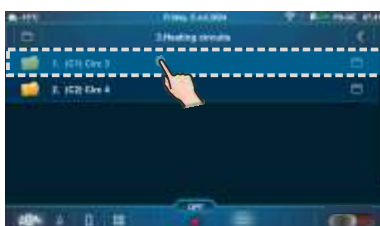
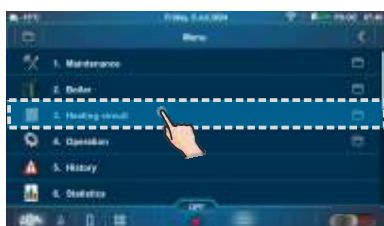

CM2K enabled

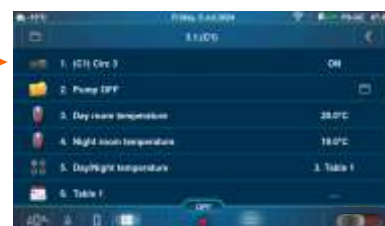

6.0. MANUAL TEST

In this menu all outputs to the connected devices (pumps/actuators) can be manually tested. Every circuit can be separately tested.

6.1. PeITec II Lambda / PeITec-Compact / BIO-SC / ZVB II

Example of manual test menu:

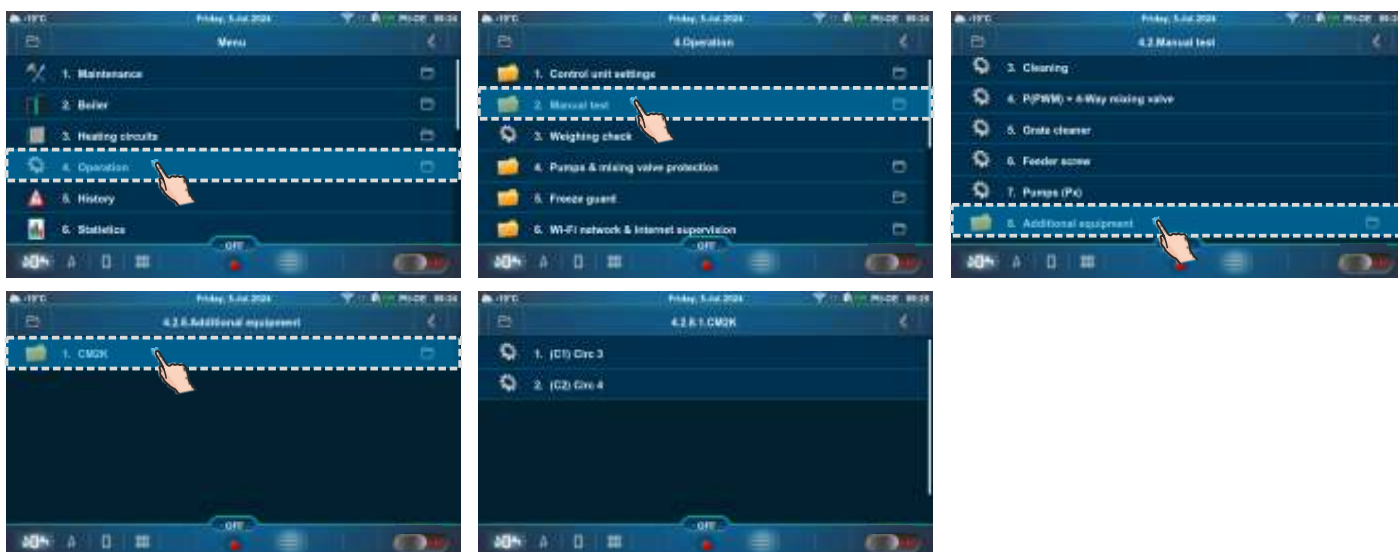

Examples:

Radiators/Constant temperature



Floor



DHC



DHW



DHW+REC



It is necessary to press the "ON" button next to the symbol of the pump/valve for which you want to check whether it is running. The pump symbol will start to rotate and button will light up green. After pressing the "OFF" button, the pump will stop operating.

If you want to check the valve, first it is necessary to turn on the opening of the valve (Open! "ON"), turn off the opening of the valve (Open! "OFF") and then turn on the closing of the valve (Close! "ON") and turn off the closing of the valve (Close! "OFF"). When the option is turned on, the pump symbol will rotate on the screen or an arrow will be displayed.

6.2. PelTec / Cm Pelet-set Touch / BioTec-L / BioTec Plus / EKO-CKS P Unit/ EKO-CKS Multi Plus

Depending of the number of enabled circuits, manual test for each circuit is shown.

Example of manual test menu:

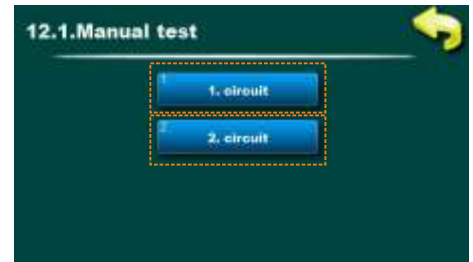

Example:

Radiator/Floor/Const. temp.



DHW



Recirculation

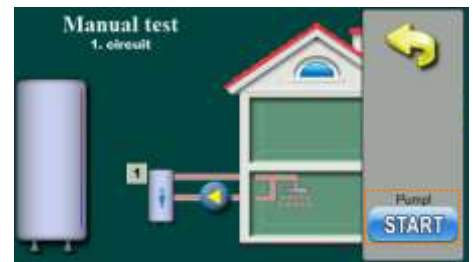

DHW + Recirculation

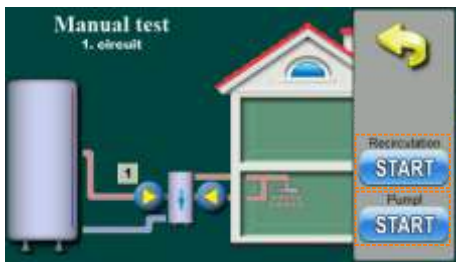

NOTE:



- By pressing the button START, pump or valve actuator opening/closing is started and this button becomes STOP
- by pressing the button STOP, pump or valve actuator opening/closing is stopped and this button becomes START
- with this options, demand for work of output/connected device is manually started, but is necessary to check if outputs is actually activated and device is actually working.

7.0. CM2K VIEW

On the boiler screen, it is possible to monitor the operation of the activated and adjusted (set) options of the CM2K module (type of circuit: Radiators / Floor heating / Constant temperature / DHW / Recirculation / DHW+Recirculation; set temperature, measured temperature, pump operation, actuator operation, switching time (schedule), operating regime...).

7.1. PeITec II Lambda / PeITec-Compact / BIO-SC / ZVB II

7.1.1. CM2K VIEW SELECTION

To access CM2K options overview, it is necessary to press the icon  which is located on the bar "Shortcuts to different screens" (a new screen with CM2K view will appear). If several CM2K are enabled, it is possible to change the view of CM2K modules (circuits) on the "Heating screen (PII-GE) (PC-GE)..." if you press the button  (one screen corresponds to one CM2K, i.e. to two circuits). To return to the "Main screen (PII-OE), (PC-OE)..." it is necessary to press the icon  or swipe right to the "Main screen (PII-OE), (PC-OE)..."



7.1.2. CIRCUIT TYPES



Changing the view of circuit

Boiler heating circuit K1

CM2K heating circuit C1

- Radiators (heating type)
- Room corrector
- Day temperature (operating regime)



CM2K heating circuit C2

- Floor (heating type)
- Room corrector
- Night temperature (operating regime)

CM2K heating circuit C3

- Constant temperature (heating type)
- Room corrector
- Day temperature (operating regime)



- CM2K heating circuit C4
 - DHC
 - Room corrector
 - Activated schedule of the Day/Night temperature



- Boiler heating circuit K2
- CM2K heating circuit C5 - DHW

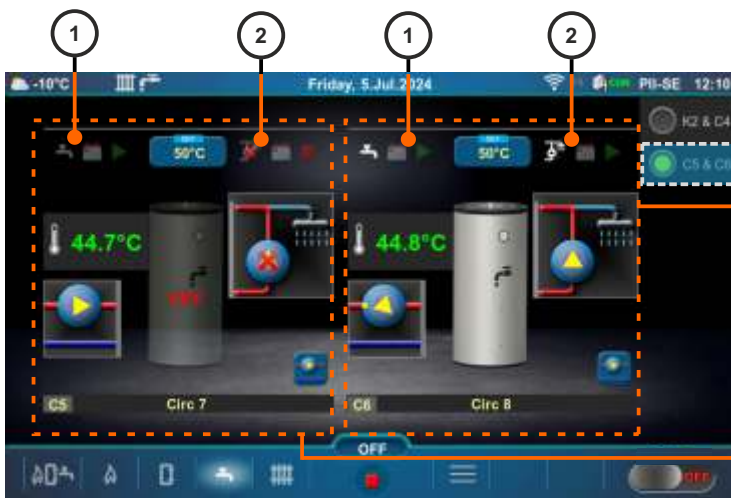

- CM2K heating circuit C6 - DHW+REC
 - DHW ON
 - Recirculation ON
 - Domestic hot water schedule (DHW) ON
 - Recirculation schedule OFF
- CM2K heating circuit C5 - DHW+REC
 - DHW OFF
 - Recirculation OFF

1 - DHW:

- DHW circuit switched OFF
- DHW circuit switched ON, domestic hot water schedule (DHW) OFF
- domestic hot water schedule (DHW) ON within the time
- domestic hot water schedule (DHW) ON out of the time

2 - Recirculation:

- switched OFF
- switched ON
- recirculation schedule ON within the time
- recirculation schedule ON out of the time

7.1.3. SYMBOLS ON THE "HEATING SCREEN"

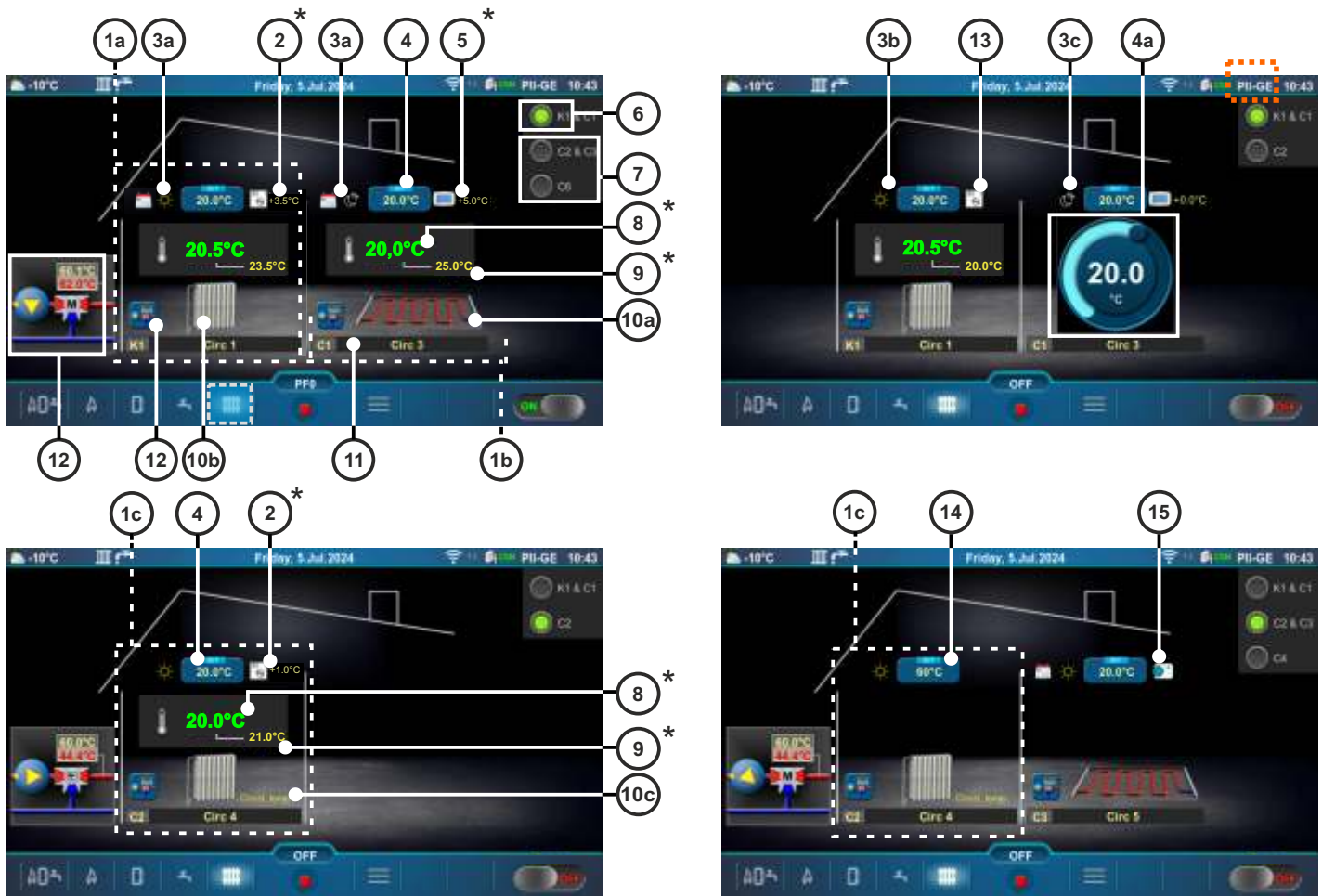







Heating screen (PII-GE), (PC-GE)...

- 1a - Boiler heating circuit K1 (Radiators - Heating type is selected)
- 1b - CM2K Heating circuit C1 (Floor - Heating type is selected)
- 1c - CM2K Heating circuit C2 (Constant temperature - Heating type is selected)
- 2 - Room temperature corrected with room corrector (3 wires) (CSK) (additional equipment)
(instead of label 2 can be label 5)
- 3a - Activated schedule of the Day/Night temperature
- 3b - Day temperature is selected
- 3c - Night temperature is selected
- 4 - Button for setting the room temperature
- 4a - Button for quick adjustment of the set room temperature
(it is activated by pressing the Button for setting the room temperature)
- 5 - Room temperature corrected with digital room corrector (CSK-Touch) (additional equipment)
(instead of label 5 can be label 2)
- 6 - Boiler heating circuit
- 7 - CM2K heating circuits (CM2K-additional equipment)
- 8 - Measured room temperature
- 9 - Set room temperature + correction
- 10a - Symbol of floor heating
- 10b - Symbol of radiator heating
- 10c - Symbol of constant temperature
- 11 - Heating circuit symbol ((K1, (K2) - boiler heating circuits), (C1...C8 - CM2K heating circuits)) and custom selected heating circuit name
- 12 - Shortcut button - 3-way mixing valve with pump, main flow set temperature and measured temperature
- 13 - Room corrector (CSK) with 2 wires
- 14 - Button for setting the main flow temperature (setting/changing the temperature is possible if the Button for setting the main flow temperature is pressed)
- 15 - Room thermostat / Reg. control (thermostat that switches the heating circuit pump on/off)

*The symbols will be shown only if corrector is selected in the heating circuit.

7.2. PelTec / Cm Pelet-set Touch / BioTec-L / BioTec Plus / EKO-CKS P Unit/ EKO-CKS Multi Plus

7.2.1. CM2K VIEW SELECTION

To access CM2K options view press button  or  on main screen (there will be new window with CM2K view or tools menu with additional button for CM2K view and other additional equipment buttons). To go back to main menu press button  or to cycle between views press . If there is more than one CM2K installed, in CM2K view, views between CM2K modules (circles) can be changed by pressing buttons   (in one view is one CM2K, i.e. two circuits).

Example: PelTec

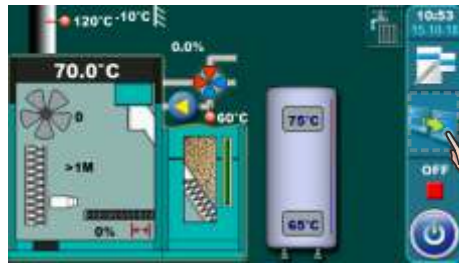

Example: BioTec-L

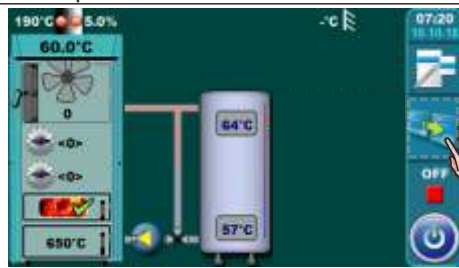

Example: Cm Pelet-set Touch



Example: BioTec Plus

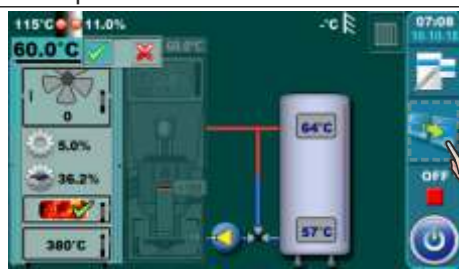

Example: EKO-CKS P Unit



Example: EKO-CKS Multi Plus

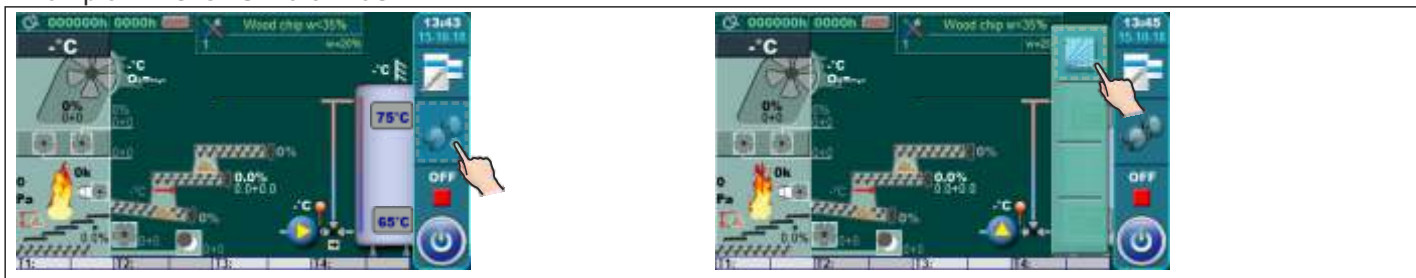

7.2.2. CIRCUIT TYPES

The diagrams show a house with a boiler and various heating circuits. The boiler has two temperature points: 75°C and 65°C. The outdoor temperature is -10°C. The house has two rooms with different heating needs.

- Circuit 2 - Floor heating room corrector night mode:** Shows a room with a floor heating system. The room temperature is 19.0°C. The boiler temperature is 40.0°C. The room setpoint is 20.0-0.0°C.
- Circuit 1 - Radiator heating room corrector day mode:** Shows a room with a radiator heating system. The room temperature is 19.0°C. The boiler temperature is 60.1°C. The room setpoint is 20.0+1.0°C.
- Circuit 4 - DHW:** Shows a room with a hot water tank. The tank temperature is 55°C. The boiler temperature is 60.0°C. The room setpoint is 20.0+5.0°C.
- Circuit 3 - Constant temp. room corrector day mode:** Shows a room with a radiator heating system. The room temperature is 25.0°C. The boiler temperature is 62.0°C. The room setpoint is 20.0+5.0°C.
- Circuit 6 - DHW + Recirculation recirculation schedule (work enabled):** Shows a room with a hot water tank and a recirculation pump. The tank temperature is 44°C. The boiler temperature is 44°C. The room setpoint is 20.0+5.0°C.
- Circuit 5 - Recirculation recirculation schedule (work disabled):** Shows a room with a hot water tank and a recirculation pump. The tank temperature is 44°C. The boiler temperature is 44°C. The room setpoint is 20.0+5.0°C.

The diagrams also show a 'Circuits view change' button on the right side of the interface.

7.2.3. CM2K VIEW EXAMPLES

1. circuit - radiator heating / room corrector / day mode (with schedule)
2. circuit - floor heating / room corrector / night mode

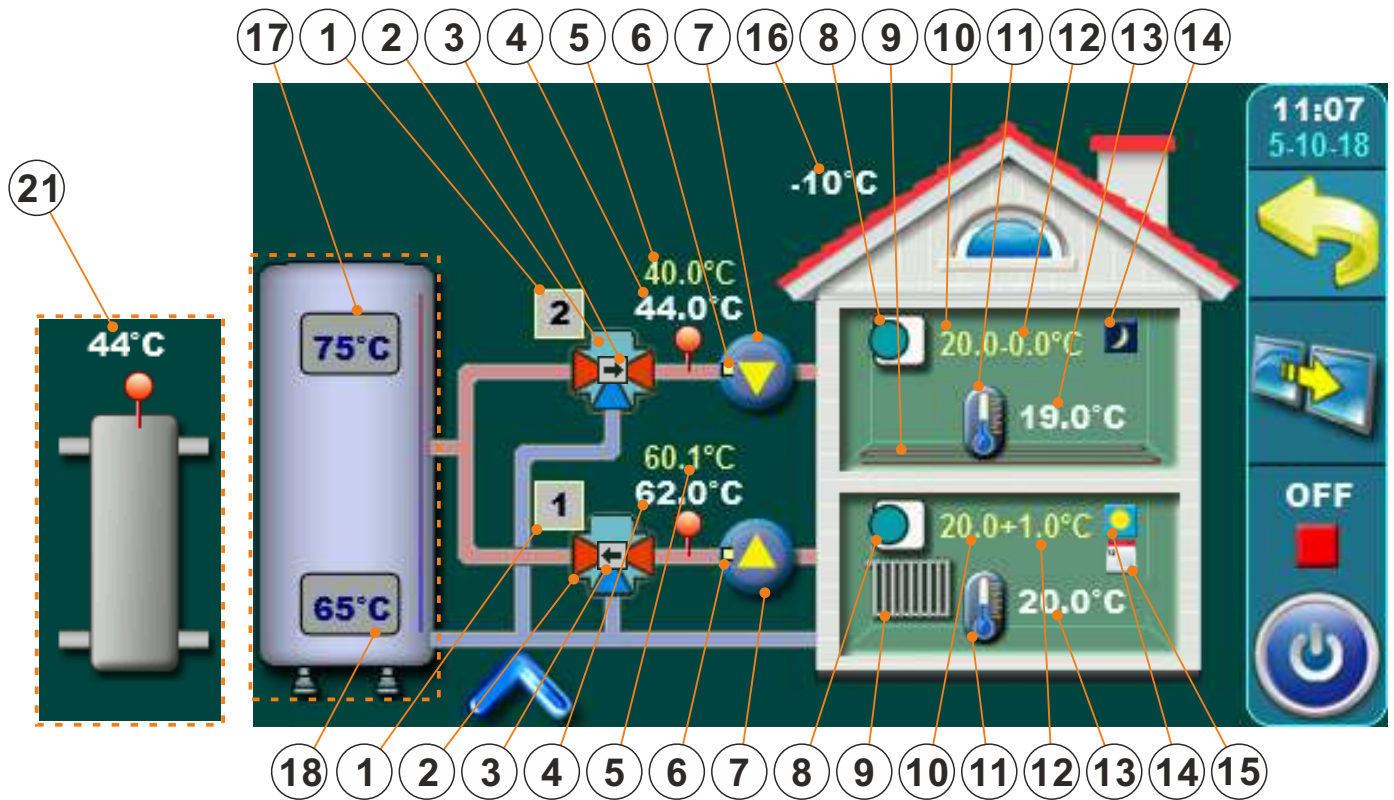

- | | |
|---|--|
| <ol style="list-style-type: none"> 1 - circuit number 2 - mixing valve with actuator 3 - actuator working indication 4 - measured main flow temp. 5 - calculated main flow temp. 6 - pump working demand indication 7 - pump 8 - room corrector 9 - circle heating type 10 - set room temp. 11 - room temp. indication | <ol style="list-style-type: none"> 12 - corrector correction setting 13 - measured room temp. 14 - work mode indication 15 - schedule/work enabled/disabled indication 16 - measured outdoor temp. 17 - measured accumulation tank upper temp. 18 - measured accumulation tank lower temp. 19 - indication of DWH tank with enabled recirculation 20 - measured DWH (domestic hot water) tank temp. 21 - measured CRO (hydraulic cross over) temp. |
|---|--|

3. circuit - constant temp. / room corrector / day mode
4. circuit - DHW

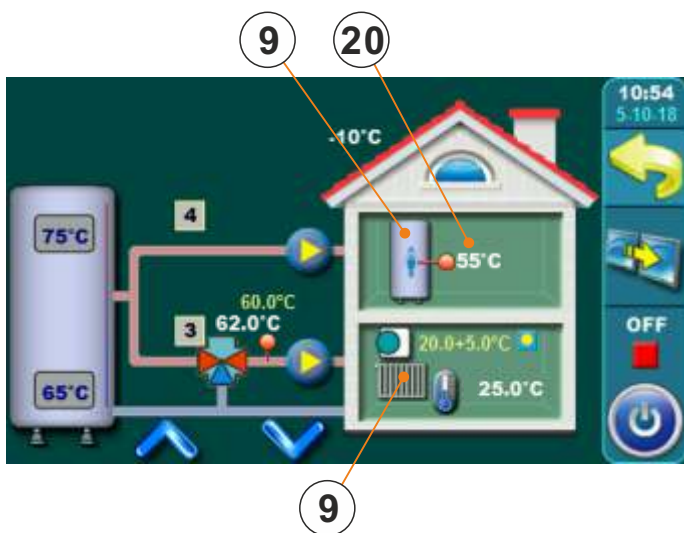

5. circuit - Recirculation / Recirculation enabled (by schedule)
6. circuit - DHW + Recirculation / Recirculation disabled (by schedule)

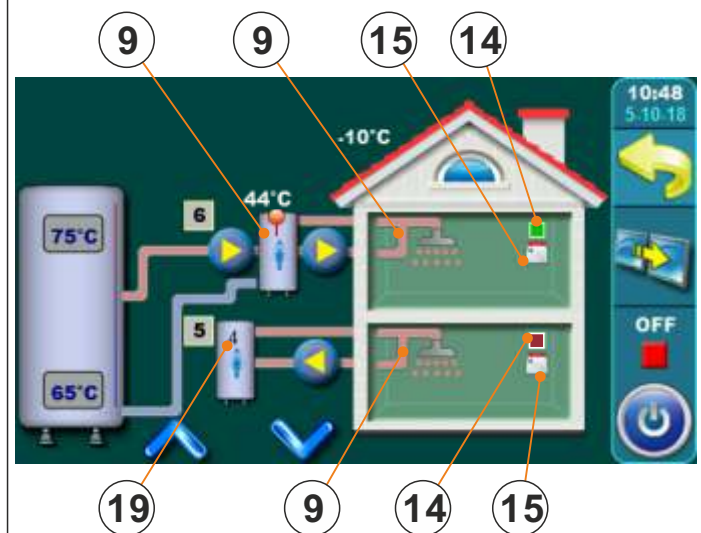

8.0. SETTING CM2K MODULE

Initial settings of operating parameters for CM2K module must be performed by an authorized service technician because module activation (enabling) and certain setting parameters are under **Installation** menu (PIN).

NOTE: next to each parameter it will be marked whether it can be changed by the service technician and the user (S/K) or only by the service technician (S).

8.1. PelTec II Lambda / PelTec-Compact / BIO-SC / ZVB II

EXAMPLE: view of the **CM2K** menu under **Installation** menu (PIN) - parameters marked (S/K) will also be displayed in the main menu under "Heating circuits" or/and "Domestic hot water" and available for setting by the user.

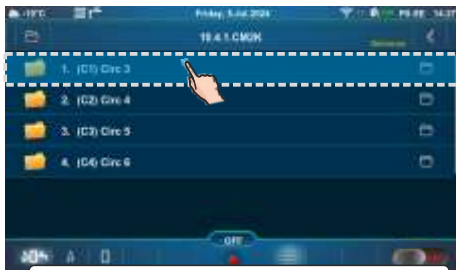

Example: No. of circuit - 2 CM2K (4 circuits)



Heating type - Disabled



Heating type - Radiators

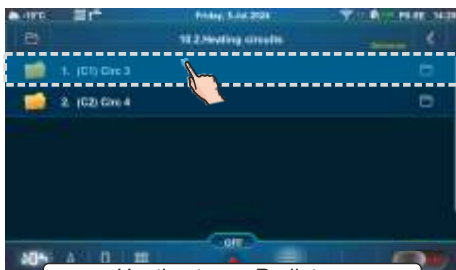

Heating type - Radiators



Heating type - Radiators



Heating type - Radiators



Heating type - Radiators

8.2. PelTec / Cm Pelet-set Touch / BioTec-L / BioTec Plus / EKO-CKS P Unit/ EKO-CKS Multi Plus

After enabling the CM2K module in main menu new icon (menu) **Regulation/CM2K** will appear. Under this menu user can adjust certain parameters of heating circuits.

EXAMPLE: view of the **CM2K** menu under **Installation** menu (PIN) - parameters with **S/K** mark will be displayed also under **CM2K** menu in the main menu so user can adjust them.

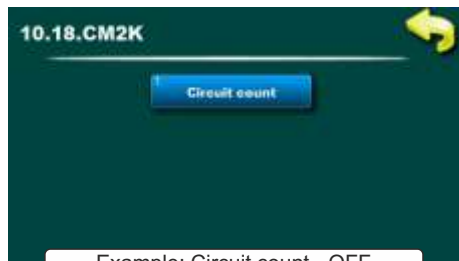

Example: Circuit count - OFF



Example: Circuit count - 2 CM2K (4 circuits)



Example: heating type - Disabled



Example: Heating type - radiator



Example: Heating type - radiator



Example: Heating type - radiator

9.0. DESCRIPTION AND VALUES OF THE PARAMETERS BY HEATING CIRCUIT TYPE

9.1. PeITec II Lambda / PeITec-Compact / BIO-SC / ZVB II

NOTE:

- the display of certain parameters in the heating circuit depends on: the corrector (if exist in the heating circuit) and selected type of corrector

(CX) Circ Y (S/K) (in this example - (C1) Circ 3)

Enable and disable heating circuit (in this example (C1) Circ 3).

This parameter is used to enable or disable heating circuit (set parameters of the circuit remain saved).

	Factory	Possible selection
(C1) Circ 3	ON	ON / OFF

Valve time (S)

This parameter defines the time (seconds), which is necessary for the mixing valve to fully open or close.

THIS VALUE MUST BE IN ACCORDANCE TO THE TIME NEEDED FOR THE ACTUATOR TO FULLY OPEN THE VALVE (DEPENDS ON THE ACTUATOR TYPE).



	Factory	Possible selection
Valve time	120 s	10-300 s

Corrector (S)

With this parameter, we adjust whether there is room corrector (thermostat), the type of corrector and external control (control).



	Factory	Possible selection
Corrector	OFF	OFF / CSK (3 wires) / CSK (2 wires) / CSK-Touch / Room thermostat/Reg. control

OFF: The corrector is not used to measure the room temperature and control the operation of the pump.

CSK (3 wires): standard connection of the corrector CSK (Centrometal) with 3 wires, the corrector measures the room temperature and the set room temperature can be corrected from -5 °C to +4.6 °C and the heating circuit can be turned OFF/ON via the corrector. The corrector is connected to pins 1, 2 and 3.

CSK (2 wires): aif there are only 2 wires for connection the corrector CSK (Centrometal), the corrector only gives information about the room temperature, the set room temperature cannot be corrected via the corrector, the heating circuit cannot be be switched ON/OFF via the corrector. The corrector is connected to pins 2 and 3.

CSK-Touch: the CSK-Touch (Centrometal) corrector can be connected wired (2 wires, to Digital inputs) or wirelessly, via the CM WiFi-box. The corrector measures the room temperature, it is possible to correct the set temperature of the room, turn OFF/ON the heating circuit, set the schedule of the heating circuit, switch ON/OFF the boiler, set the temperatures of the boiler, the accumulation (buffer) tank and the DHW tank, set the schedule of the boiler and the DHW circuit, there are messages about errors and warnings on the boiler and heating, if there is a connection to the Internet, the display of the weather forecast...

Room thermostat/Reg. control: control of the heating circuit pump by external regulation such as a voltage-free room thermostat or a floor heating control terminal block. The room temperature cannot be read on the boiler screen. External regulation (control terminal block, room thermostat...) is connected to pins 1 and 2.

Note:

The CSK and CSK-Touch room correctors impact to the set circuit heating curve (i.e. to the calculated main flow temperature) by room temperature correction.

CSK-Touch

The number of the "Installation" menu depends and changes depending on the selected configuration.

1. Enable CSK-Touch in the menu "Additional equipment"
(Installation -> Commissioning -> Configuring -> Additional equipment -> CSK-Touch)
2. Select the CSK-Touch corrector in the menu "Heating circuits"
(Heating circuits -> (CX) Circ Y -> Corrector -> CSK-Touch)
3. Select the address of the digital corrector
(Digital corrector address)
4. To adjust CSK-Touch, use "Info". For a detailed description see "Technical instruction CSK-Touch."
(Additional equipment -> CSK-Touch -> Info)

Heating curve (S/K)

Setting of the heating curve.

Heating curve is one of the parameters for main flow temperature calculation.

	Factory	Possible selection
Heating curve	1.0	0.1 - 4.0

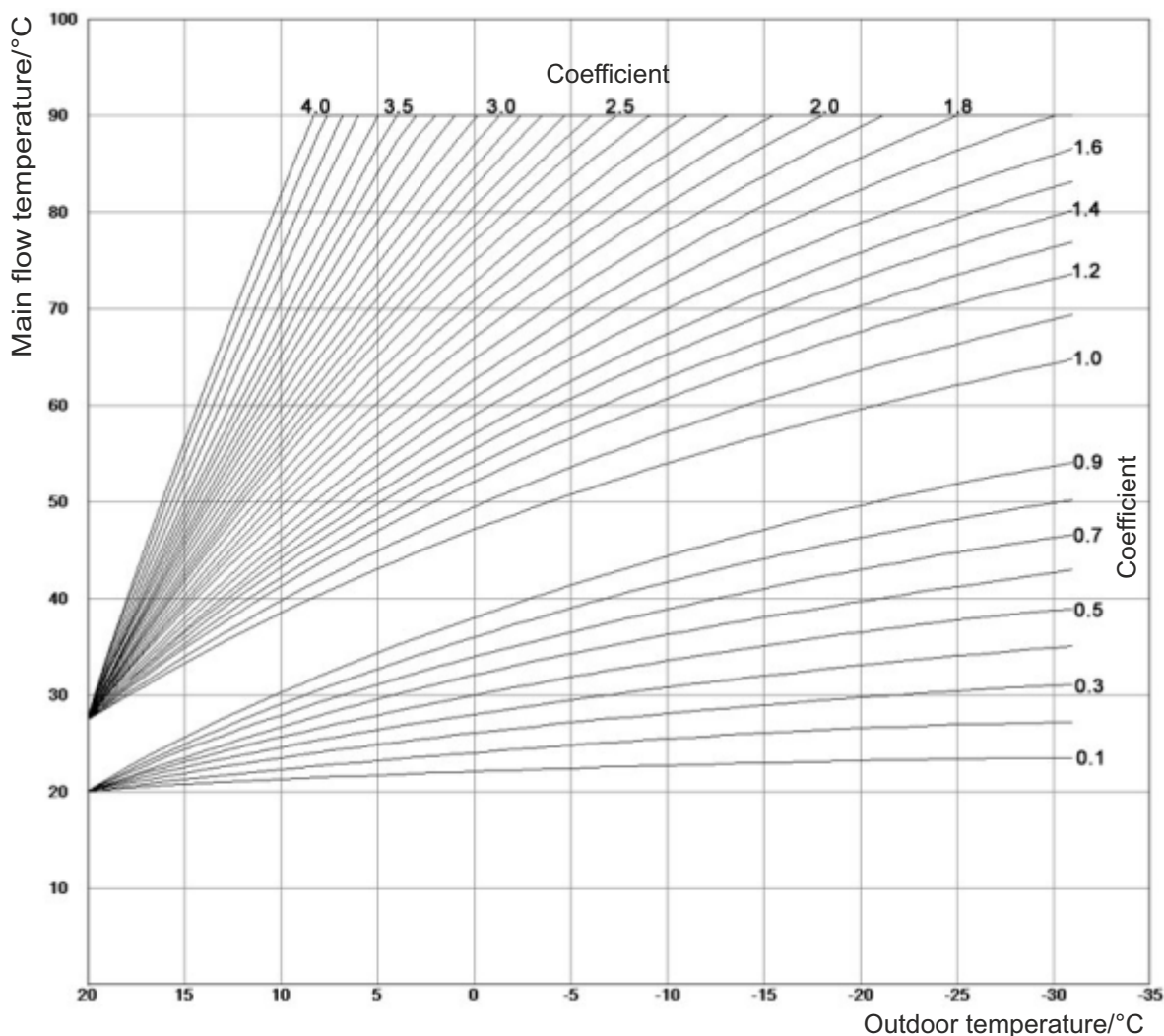

Figure 1: Heating curve

Correction coefficient (S)

Setting the correction coefficient for room corrector.

This parameter is used for setting the correction coefficient of the room corrector which will be used for main flow temperature calculation. Higher value of this parameter, higher effect it will have on main flow temp. calculation. This parameter is used only if room corrector is installed.



	Factory	Possible selection
Correction coefficient	1.0	0.1 - 5.0

Pump OFF (S/K)

This menu is used for setting the parameters for switching off circuit pump according outdoor temperature and settings in this menu (does not affect DHW and Recirculation).

It consists of 3 options: Outdoor temperature / Outdoor temperature difference / Time

Pump OFF - Outdoor temperature (S/K)

Setting the outdoor temperature.

This parameter determines the outdoor temperature at which the heating pump will be switched off.

	Factory	Possible selection
Outdoor temperature	22 °C	0 - 40 °C

Pump OFF - Outdoor temperature difference (S/K)

Setting the outdoor temperature difference.

This parameter is used to set difference on which heating pump will start again and delay time will be reset.

	Factory	Possible selection
Outdoor temperature difference	2 °C	0 - 5 °C

Pump OFF - Time (S/K)

Setting the time.

This parameter is used to set time delay for switching off the pump when temperature for pump switching off is reached.

	Factory	Possible selection
Time	30 min	0 - 10080 min

Day room temperature (S/K)

Setting the day room temperature. This parameter determines the desired daily room temperature of the heating circuit.

	Factory	Possible selection
Day room temp.	20 °C	5.0 - 30.0 °C

Night room temperature (S/K)

Setting the night room temperature. This parameter determines the desired night room temperature of the heating circuit.

	Factory	Possible selection
Night room temp.	20 °C	5.0 - 30.0 °C

Day/Night temperature (S/K)

Setting the operating mode of heating circuit.

This parameter is used to set the operating mode of heating circuit. Selecting the Day temperature heating circuit always works according to the set day temperature, selecting the Night temperature heating circuit always works according to the set night temperature and by selecting the Table 1/2 heating circuit automatically switches operation mode between set day and set night temperature according to the time set in the Table 1/2.

	Factory	Possible selection
Day/Night temp.	Day temperature	Day temperature/Night temperature/Table 1/Table 2

Table 1 / Table 2 (S/K)

Setting the schedule tables with switching the heating circuit operation mode between day and night temperature. For each day, 5 operating mode changes can be set. In the table Day room temperatures are marked in yellow and night room temperatures in black. It is possible to set a schedule for one day and copy the same schedule for all other days. Under "COPY TO:", mark the day or days for which you want to have the same schedule and confirm by pressing the "CONFIRM" button. Two tables can be set, but only one can be active.



"CONFIRM" button

(yellow) Day room temperature set

(black) Night room temperature set

Transition time (S)

This parameter is used only when there is no room corrector in the heating circuit, because the controller has no information about the room temperature. This is presumed time in which system will achieve set room temperature between switching from day to night mode and vice versa, i.e. in which time main flow temperature will be optimized for quick transition.



	Factory	Possible selection
<i>Transition time</i>	3600 sec	0 - 18000 sec

Note:

If the "CSK" room corrector (additional equipment) is connected to the CM2K module, the "Transition time" parameter is not used (it is not functional).

dT pump Off (S)

Setting the room corrector difference.

This parameter is used to set how many °C measured room temperature must be higher than set room temperature to switch off the heating circuit pump (it is used only if a room corrector is installed).



	Factory	Possible selection
<i>dT pump Off</i>	0.5 °C	0.0 - 3.0 °C

dT pump On (S)

Setting the room corrector difference.

This parameter is used to set how many °C measured room temperature must be lower than set room temperature to switch on the heating circuit pump (it is used only if a room corrector is installed).



	Factory	Possible selection
<i>dT pump On</i>	0.5 °C	0.0 - 3.0 °C

Measurement correction - Corrector (S/K)

This parameter is used to adjust the correction of the measured temperature (in the room) with the CSK corrector (possible reason for the correction - the room corrector CSK is placed in a part of the room that is for some reason warmer or colder than the rest of the room).

	Factory	Possible selection
<i>Measurement correction - Corrector</i>	0.0 °C	-5.0 / 5.0 °C

Digital corrector address (S)

This parameter is used to select the unique address of the digital corrector for connecting to the controller.



	Factory	Possible selection
<i>Digital corrector address</i>	Not defined	Not defined, ADDR 1, ADDR 2, ADDR 3, ADDR 4, ADDR 5, ADDR 6, ADDR 7, ADDR 8

Minimal buffer tank temperature (S/K)

The possibility of setting the desired minimum temperature of the buffer tank for each heating circuit (disable the water temperature cooling in the buffer tank below the set temperature for each heating circuit). When the temperature of the upper sensor of the buffer tank is lower than the set minimum temperature of the buffer tank for an individual heating circuit, the heating pump of the corresponding heating circuit is switching off.

	Factory	Possible selection
<i>Minimal buffer tank temperature</i>	20 °C	5 - 75 °C

DHW temperature (S/K)

Setting the DHW tank temperature. This parameter is used to set desired temperature of the DHW (domestic hot water) tank.

	Factory	Possible selection
<i>DHW temperature</i>	50 °C	40 - 80 °C

DHW difference (S/K)

Setting the DHW difference. This parameter is used to set desired difference of the DHW (domestic hot water) tank.

	Factory	Possible selection
<i>DHW difference</i>	5 °C	4 - 40 °C

9.1.1. RADIATORS / FLOOR

(CX) Circ Y **(S/K)** - see page 28
 Valve time **(S)** - see page 28
 Corrector **(S)** - see page 28
 Heating curve **(S/K)** - see page 29
 Correction coefficient **(S)** - see page 29
 Pump OFF **(S/K)** - see page 29
 Pump OFF - Outdoor temperature **(S/K)** - see page 29
 Pump OFF - Outdoor temperature difference **(S/K)** - see page 29
 Pump OFF - Time **(S/K)** - see page 30
 Day room temperature **(S/K)** - see page 30
 Night room temperature **(S/K)** - see page 30
 Day/Night temperature **(S/K)** - see page 30
 Table 1 / Table 2 **(S/K)** - see page 30
 Transition time **(S)** - see page 31
 dT pump Off **(S)** - see page 31
 dT pump On **(S)** - see page 31
 Measurement correction - Corrector **(S/K)** - see page 31
 Digital corrector address **(S)** - see page 31
 Minimal buffer tank temperature **(S/K)** - see page 31

Radiator maximal temperature / Floor heating maximal temperature **(S)**

Setting the main flow maximum temperature. This parameter is used to set mixing circuit main flow maximum temperature.



	Factory	Possible selection
Radiator maximal temperature	90 °C	20 - 90 °C
Floor heating maximal temperature	40 °C	20 - 55 °C

9.1.2. CONSTANT TEMPERATURE

(CX) Circ Y **(S/K)** - see page 28
 Valve time **(S)** - see page 28
 Corrector **(S)** - see page 28
 Heating curve **(S/K)** - see page 29
 Correction coefficient **(S)** - see page 29
 Pump OFF **(S/K)** - see page 29
 Pump OFF - Outdoor temperature **(S/K)** - see page 29
 Pump OFF - Outdoor temperature difference **(S/K)** - see page 29
 Pump OFF - Time **(S/K)** - see page 30
 Day room temperature **(S/K)** - see page 30
 Night room temperature **(S/K)** - see page 30
 Day/Night temperature **(S/K)** - see page 30
 Table 1 / Table 2 **(S/K)** - see page 30
 Transition time **(S)** - see page 31
 dT pump Off **(S)** - see page 31
 dT pump On **(S)** - see page 31
 Measurement correction - Corrector **(S/K)** - see page 31
 Digital corrector address **(S)** - see page 31
 Minimal buffer tank temperature **(S/K)** - see page 31

Day constant temperature **(S/K)**

Setting the constant temperature of the circuit's main flow for the daily operation mode. This parameter determines the desired temperature of the main flow for the daily operation mode.

	Factory	Possible selection
Day constant temperature	60 °C	20 - 90 °C

Night constant temperature **(S/K)**

Setting the constant temperature of the circuit's main flow for the night operation mode. This parameter determines the desired temperature of the main flow for the night operation mode.

	Factory	Possible selection
Night constant temperature	40 °C	20 - 90 °C

9.1.3. DHC

- (CX) Circ Y **(S/K)** - see page 28
- Corrector **(S)** - see page 28
- Pump OFF **(S/K)** - see page 29
- Pump OFF - Outdoor temperature **(S/K)** - see page 29
- Pump OFF - Outdoor temperature difference **(S/K)** - see page 29
- Pump OFF - Time **(S/K)** - see page 30
- Day room temperature **(S)** - see page 30
- Night room temperature **(S)** - see page 30
- Day/Night temperature **(S)** - see page 30
- Table 1 / Table 2 **(S)** - see page 30
- Measurement correction - Corrector **(S/K)** - see page 31
- Digital corrector address **(S)** - see page 31
- Minimal buffer tank temperature **(S/K)** - see page 31

9.1.4. DHW

- (CX) Circ Y **(S/K)** - see page 28
- DHW temperature **(S/K)** - see page 31
- DHW difference **(S/K)** - see page 31

Domestic hot water schedule (DHW) **(S/K)**

Setting the schedule for DHW. With this parameter, switching times can be activated or deactivated, and the active table can be selected according to which, the switching times will work.

	Factory	Possible selection
Domestic hot water schedule (DHW)	OFF	OFF / Table 1 / Table 2

Table 1 / Table 2 **(S/K)**

Setting the DHW schedule tables. This parameter is used to set the tables according to which the switching times will work. Only one table can be active.

9.1.5. DHW + REC

- (CX) Circ Y **(S/K)** - see page 28
- DHW temperature **(S/K)** - see page 31
- DHW difference **(S/K)** - see page 31

Domestic hot water schedule (DHW) **(S/K)**

Setting the schedule for DHW. With this parameter, switching times can be activated or deactivated, and the active table can be selected according to which, the switching times will work.

	Factory	Possible selection
Domestic hot water schedule (DHW)	OFF	OFF / Table 1

Table 1 **(S/K)**

Setting the schedule table with switching the heating circuit operation mode between day and night temperature. For each day, 5 operating mode changes can be set. In the table Day room temperatures are marked in yellow and night room temperatures in black. It is possible to set a schedule for one day and copy the same schedule for all other days. Under "COPY TO:", mark the day or days for which you want to have the same schedule and confirm by pressing the "CONFIRM" button.

Recirculation **(S/K)**

Activation of recirculation: it is possible to enable or disable recirculation without changing other parameters.

	Factory	Possible selection
Recirculation	ON	ON / OFF

Recirculation Time On **(S)**

Recirculation pump operation time. Setting the recirculation pump operation time when recirculation is active.



	Factory	Possible selection
Recirculation Time On	5 min	0 - 1440 min

Recirculation Time Off **(S)**

Recirculation pump stop time. Setting the recirculation pump stop time when recirculation is active.



	Factory	Possible selection
Recirculation Time Off	5 min	0 - 1440 min

Recirculation schedule **(S/K)**

The possibility of activating and deactivating recirculation switching times..

	Factory	Possible selection
Recirculation schedule	OFF	ON / OFF

Recirculation table S/K

Setting the table of recirculation operation.

For each day of the week, it is possible to set 5 time intervals during which recirculation will operate and 5 time intervals during which it will not operate (T1-T5). Time intervals in which recirculation will operate are marked in yellow, while the intervals in which recirculation will not operate are marked in black. It is possible to set a schedule for one day and copy the same schedule for all other days. Under "COPY TO:", mark the day or days for which you want to have the same recirculation schedule and confirm by pressing the "CONFIRM" button.



"CONFIRM" button

<p> (yellow) Recirculation operation enabled</p>	<p> Recirculation operation disabled</p>
---	---

9.2. PelTec / Cm Pelet-set Touch / BioTec-L /BioTec Plus / EKO-CKS P Unit/ EKO-CKS Multi Plus

NOTES:

- at initial circle view (before adjusting) are only certain parameters shown (X. circuit / Valve time / Heating type / Corrector). After adjusting the circuit heating type, in main menu of heating circuit, other parameters will be shown according the set heating type.
- certain parameters depends of the boiler type to which CM2K is installed and view is set according to this. Because of this, certain parameters are shown or not shown depending of the boiler type.

Circuit count **(S)**

This parameter is used to set number of CM2K modules i.e. number of circuits (1 CM2K = 2 circuits)

By selecting and confirmation of CM2K modules this parameter is enabled.



Factory setting	setting	
Circuit count	OFF	OFF / 1xCM2K... 4xCM2K

X. circuit **(S/K)** (in this example - 1. circuit)

Enable and disable heating circuit.

This parameter is used to enable or disable heating circuit (set parameters are stored).

Factory setting	setting	
1. circuit	ON	OFF/ON

Valve time **(S/K)**

Setting the mixing valve actuator speed.

This parameter is used for setting the speed of the mixing valve actuator speed for work of 90° (open/close). It must be set according the installed mixing valve actuator speed.

Factory setting	setting	
Valve time	120 sec	10-300 sec

Heating type **(S)**

Setting the heating circuit type.

This parameter is used to set heating circuit type. After setting the heating circuit type, in main menu of the circuit, other setting parameters will be shown according the heating circuit type.



Factory setting	setting	
Heating type	Disabled	Disabled/Radiator/Floor/Constant temp./DHW/*Pool/Recirculation/DHW+Recirculation

* NOT USED

Corrector **(S)**

With this parameter, we adjust does if exist a room corrector (thermostat) or not, the type of corrector, and external control.



Factory setting	setting	
Corrector	OFF	OFF / CSK (3 wires) / CSK (2 wires) / CSK-Touch / Reg. control

OFF: The corrector is not used to measure the room temperature and control the operation of the pump.

CSK (3 wires): standard connection of the corrector CSK (Centrometal) with 3 wires, the corrector measures the room temperature and the set room temperature can be corrected from -5°C to +4.6°C and the heating circuit can be turned OFF/ON via the corrector. The corrector is connected to pins 1, 2 and 3.

CSK (2 wires): if there are only 2 wires for connecting the corrector CSK (Centrometal), the corrector only gives information about the room temperature, the set room temperature cannot be corrected via the corrector, not can the heating circuit be switched ON/OFF via the corrector. The corrector is connected to pins 2 and 3.

CSK-Touch: the CSK-Touch (Centrometal) corrector can be connected wired (2 wires, to Digital inputs) or wirelessly, via the CM WiFi-box. The corrector measures the room temperature, it is possible to correct the set temperature of the room, turn OFF/ON the heating circuit, set the schedule of the heating circuit, switch ON/OFF the boiler, set the temperatures of the boiler, the accumulation tank and the DHW tank, set the schedule of the boiler and the DHW circuit, there are messages about errors and warnings on the boiler and heating, if there is a connection to the Internet, the display of the weather forecast...

Reg. control: control of the heating circuit pump by external regulation such as a floor heating control terminal block or a voltage-free room thermostat. The room temperature cannot be read on the boiler screen. External regulation (control terminal block, room thermostat...) is connected to pins 1 and 2.

Note:

The CSK and CSK-Touch room correctors are related to the set circuit heating curve (ie to the calculated main flow temperature) by room temperature correction.

9.2.1. RADIATOR / FLOOR

- X. circuit (S/K) - see page 35
- Valve time (S) - see page 35
- Heating type (S) - see page 35
- Corrector (S) - see page 35

Heating curve (S/K)

Setting of the heating curve.

Heating curve is one of the parameters for main flow temp. calculation.

Factory setting		setting
Heating curve	1.0	0.1-4.0

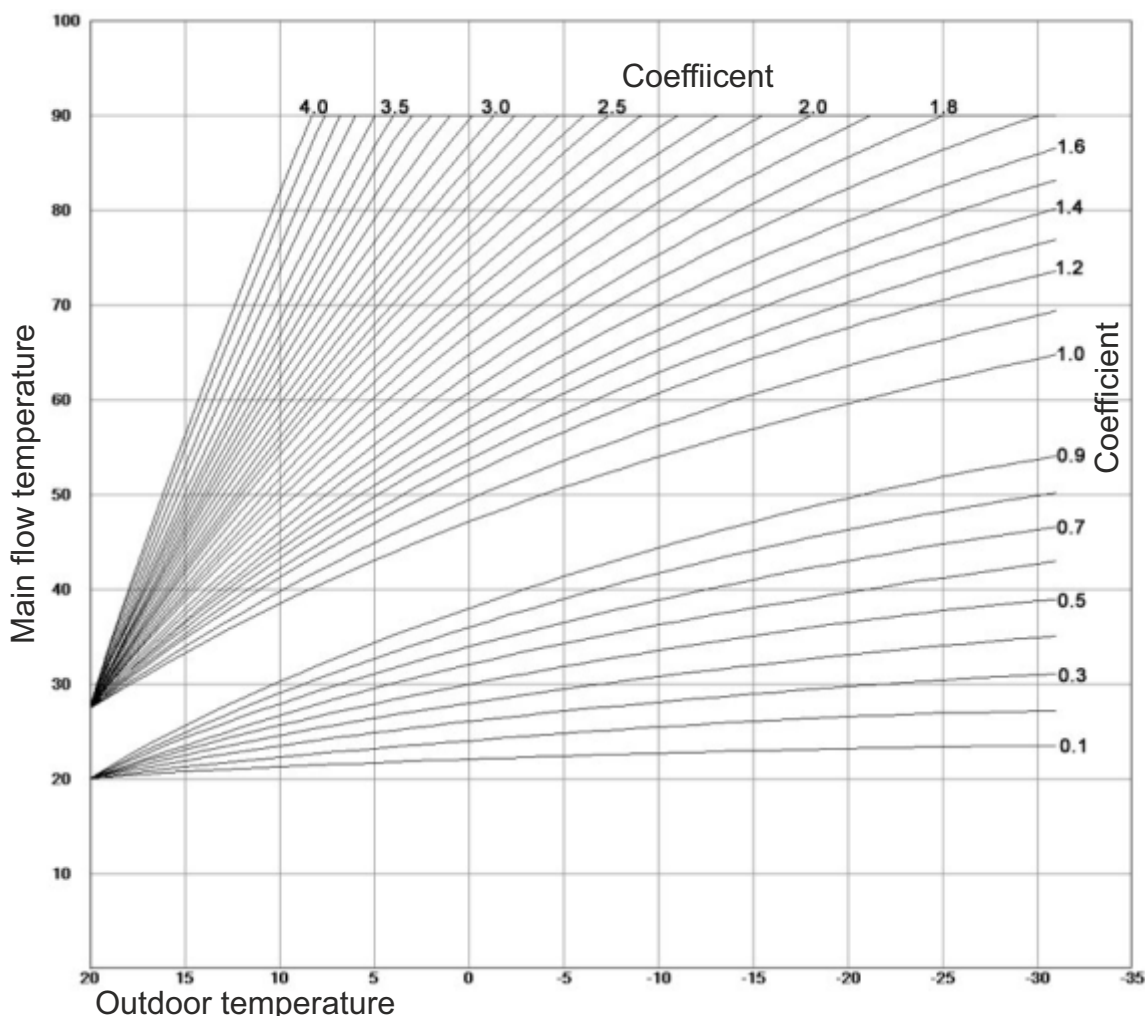

Day / Night temp. (S/K)

Setting the heating circuit mode.

This parameter is used to set heating circuit mode. Selecting the Day temp. heating circuit always works according set day temp., selecting the Night temp. heating circuit always works according set night temp. and by selecting the Table 1/2, heating circuit automatically switches mode between set day and set night temp. according the time set in the Table 1/2.

Factory setting		setting
Day/night temp.	Day temp.	Day temp. / Night temp. / Table 1 / Table 2

Table 1 / Table 2 (S/K)

Setting the schedule tables with heating circuit mode switching between day and night temp.. For each day 3 mode switching can be set. All settings from one day can be selected and copy/paste to any another day of the week. After any adjustment they must be confirmed by pressing OK button to save the settings. Two tables can be set but only one can be active.

Labels in the first screenshot:

- week day day selecting button
- circuit number
- back button
- day temp.
- night temp.
- time setting area (buttons)

Labels in the second screenshot:

- entire day selected
- copy button
- paste button

Label in the third screenshot:

- OK (confirmation) button

Correction coefficient (S/K)

Setting the correction coefficient for room corrector.

This parameter is used for setting the correction coefficient of the room corrector which will be used for main flow temp. calculation. Higher value of this parameter, higher effect it will have on main flow temp. calculation. This parameter is used only if room corrector is installed.

Factory setting		setting
Correction coeff.	1.0	0.1 - 5.0

Pump off (S/K)

This menu is used for setting the parameters for switching off circuit pump according outdoor temperature and settings in this menu (doesn't affect DHW and Recirculation).

It has 3 options: **Outside temp.** / **Difference** / **Time**

Toutside (S/K)

Setting outside temperature.

This parameter is used to set according which outside temp. circuit pump will stop.

Factory setting		setting
Toutside	20°C	0 - 40°C

Out temp. difference (S/K)

Setting the difference.

This parameter is used to set difference on which circuit pump will start again and delay time will be reset.

Factory setting		setting
Out. temp. difference	2°C	0 - 5°C

Time (S/K)

Setting the time.

This parameter is used to set time delay for switching off the circuit pump when temperature for pump switching off is reached.

Factory setting		setting
Time	30 min	0 - 600 min

Min. temperature radiator / floor / constant temp. (S)

Setting the main flow min. temp.

This parameter is used to set mixing circuit main flow min. temp..



Factory setting		setting
Min. temp. radiator/floor/constant temp.	20°C	20 - 90°C

Max. temperature radiator / floor / constant temp. (S)

Setting the main flow max. temp.

This parameter is used to set mixing circuit main flow max. temp..



Factory setting		setting
Max. temp. radiator/floor/constant temp.	90°C	20 - 90°C

Day room temperature (S/K)

Setting the day room temp.

This parameter is used to set desired heating circuit day room temperature.

Factory setting		setting
Day room temp.	20°C	5.0. - 30.0°C

Night room temperature (S/K)

Setting the night room temp.

This parameter is used to set desired heating circuit night room temperature.

Factory setting		setting
Night room temp.	20°C	5.0. - 30.0°C

dT pump off (S)

Setting the room corrector difference.

This parameter is used to set how many °C measured room temp. must be higher than set room temp. to switch off the circuit pump (only if room coreector is installed).



Factory setting		setting
dT pump Off	0.5°C	0.0. - 3.0°C

dT pump on (S)

Setting the room corrector difference.

This parameter is used to set how many °C measured room temp. must be lower than set room temp. to switch on the circuit pump (only if room coreector is installed).



Factory setting		setting
dT pump On	0.5°C	0.0. - 3.0°C

Transition time (S/K)

This parameter is used only when there isn't room corrector installed because regulation doesn't have info regarding measured room temp. This is presumed time in which system will achieve set room temp. between switching from day to night mode and vice versa, i.e. in which time main flow temp. will be optimized for quick transition.

Factory setting		setting
Transition time	3600 sec	0 - 18000 sec

Note:

If room corrector CSK (additional equipment) is connected to the CM2K, this parameter is not used.

9.2.2. CONSTANT TEMPERATURE

X. circuit (S/K) - see page 35

Valve time (S) - see page 35

Heating type (S) - see page 35

Corrector (S) - see page 35

Pump off (S/K) - see page 38

Day room temp. (S/K) - see page 38

Night temp. (S/K) - see page 38

Day / Night temp. (S/K) - see page 36

Table 1/2 (S/K) - see page 37

dT pump off (S) - see page 38

dT pump on (S) - see page 38

Transition time (S/K) - see page 39

Day constant temp. (S/K)

Setting the circuit main flow constant temp. for day mode.

This parameter is used to set desired circuit main flow constant temp. for day mode.

Factory setting		setting
Day constant temp.	60°C	20 - 90°C

Night constant temp. (S/K)

Setting the circuit main flow constant temp. for night mode.

This parameter is used to set desired circuit main flow constant temp. for night mode.

Factory setting		setting
Night constant temp.	60°C	20 - 90°C

9.2.3. DHW

X. circuit (S/K) - see page 35

Heating type (S) - see page 35

DHW Temperature (S/K)

Setting the DHW tank temperature.

This parameter is used to set desired DHW tank (domestic hot water) temp.

Factory setting		setting
DHW temp.	50°C	40 - 80°C

DHW difference (S/K)

Setting the DHW difference.

This parameter is used to set desired DHW tank (domestic hot water) difference.

Factory setting		setting
DHW difference	5°C	4 - 40°C

DHW schedule (S/K)

Setting the schedule for DHW.

this parameter is used to set if DHW schedule is active or not and select active Table 1/2 according to which schedule will work.

Factory setting		setting
DHW schedule	OFF	OFF / Table 1 / Table 2

Table1 / Table 2 (S/K)

Setting the DHW schedule tables.

This parameter is used for setting the tables according DHW schedule will work. Only one table can be active.

9.2.4. RECIRCULATION

X. circuit (S/K) - see page 35

Heating type (S) - see page 35

DHW circuit (S)

Setting the DHW circuit for which recirculation will be enabled. 

DHW circuit which has circulation installed must be selected. Selecting the DHW circuit must be done according how this circuit is regulated (boiler or one of CM2K circuits).

Sensor installed (S) 
 NOT USED

Time On rec. (S/K)
 Recirculation pump work time.
 Setting the recirculation pump work time when recirculation is active.

Factory setting		setting
Time On rec.	5 min	0 - 1440 min

Time Off rec. (S/K)
 Recirculation pump stop time.
 Setting the recirculation pump stop time when recirculation is active.

Factory setting		setting
Time Off rec.	5 min	0 - 1440 min

Recirculation table (S/K)
 Recirculation work and stop table.

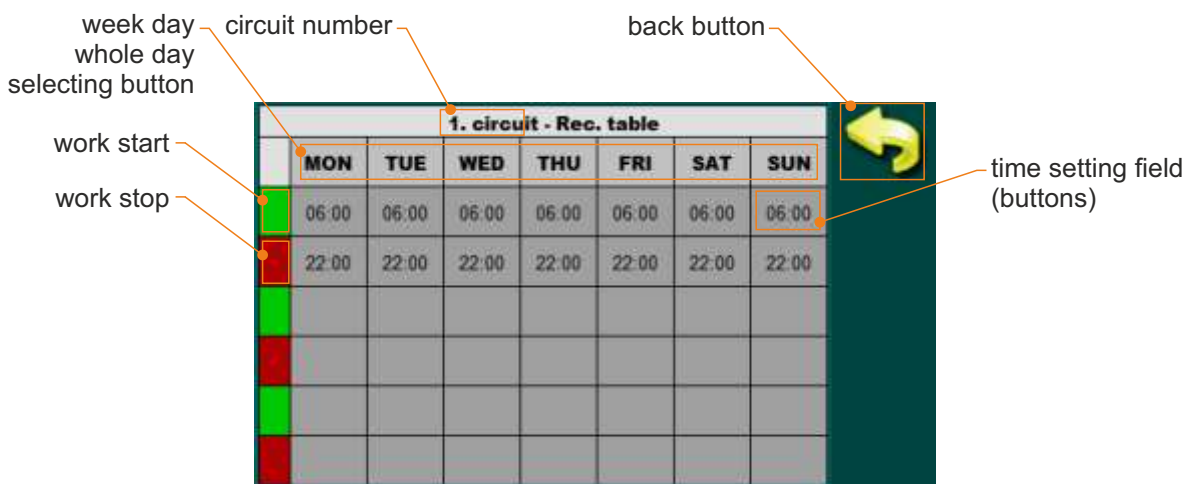

Annotations for the first screenshot:

- week day whole day selecting button
- circuit number
- back button
- work start
- work stop
- time setting field (buttons)

1. circuit - Rec. table							
	MON	TUE	WED	THU	FRI	SAT	SUN
work start	06:00	06:00	06:00	06:00	06:00	06:00	06:00
work stop	22:00	22:00	22:00	22:00	22:00	22:00	22:00



Annotations for the second screenshot:

- whole day select
- copy button
- paste button

1. circuit - Rec. table							
	MON	TUE	WED	THU	FRI	SAT	SUN
work start	06:00	06:00	06:00	06:00	06:00	06:00	06:00
work stop	22:00	22:00	22:00	22:00	22:00	22:00	22:00



Annotation for the third screenshot:

- OK (confirmation) button

1. circuit - Rec. table							
	MON	TUE	WED	THU	FRI	SAT	SUN
work start	06:00	06:00	06:00	06:00	06:00	06:00	06:00
work stop	22:00	22:00	22:00	22:00	22:00	22:00	22:00

9.2.5. DHW + RECIRCULATION

X. circuit (S/K) - see page 35

Heating type (S) - see page 35

DHW temp. (S/K) - see page 39

DHW difference (S/K) - see page 39

Time On rec. (S/K) - see page 40

Time Off rec. (S/K) - see page 40

DHW schedule (S/K) - see page 39

Table 1 (S/K) - see page 37

Recirculation table (S/K) - see page 40

Centrometal

HEATING TECHNIQUE



Company assumes no responsibility for possible inaccuracies in this book originated typographical errors or rewriting, all figures and diagrams are principal and it is necessary to adjust each actual situation on the field, in any case the company reserves the right to enter their own products such modifications as considered necessary.

Centrometal d.o.o. Glavna 12, 40306 Macinec, Croatia

central tel: +385 40 372 600, fax: +385 40 372 611
service tel: +385 40 372 622, fax: +385 40 372 621

www.centrometal.hr
e-mail: servis@centrometal.hr