

Operation and maintenance manual

CONTENTS

1. General information	4
Introduction	4
Application	4
Technical specifications	4
2. Design	5
Description	5
3. Burner accessories	9
4. Safety, burner installation and commissioning	10
Safety and connection of the burner to the boiler	10
Design and technical measures for increasing safety	10
Basic dimensions of the opening for installation of the burner in a boiler	11
5. Type of environment and location of the boiler with the burner in the boiler room	13
6. Chimney	13
7. Flue gas duct of the boiler	14
8. Fire protection within the installation and use of heat appliances	14
9. Basic connection diagram of a D30P, D40P, D50P (D45P), P30, P40, P50 boiler with an accumulation tank for burner control on the basis of TS and TV sensors	16
10. Connection of boilers D30P, D40P, D50P (D45P), P30, P40, P50 with an accumulation tank for burner control on the basis of TS and TV sensors and control of the boiler pump on the basis of the TK sensor	17
11. Connection of boilers D30P, D40P, D50P (D45P), P30, P40, P50 with an accumulation tank with solar heating for burner control on the basis of TS, TK and TV sensors (automatic sensor switching function), function of controlling the solar pump based on TSV and TS temperatures	18
12. Connection of boilers D30P, D40P, D50P (D45P), P30, P40, P50 with electronic regulation ACD 03 and accumulation tank with solar heating	19
13. Connection of boilers DCxxS(X), CxxS(T), ACxxS, KCxxS, DCxxRS with built-in burner in upper doors with accumulation tank for regulation of the burner based on sensors TS and TV and control of boiler pump based on TK sensor	20
14. Connection of boilers DCxxS(X), CxxS(T), ACxxS, KCxxS, DCxxRS with built-in burner in upper doors and with ACD 03/04 electronic regulation	21
15. Connection of the boiler and burner to the electric mains	22
16. Connection diagram of the electronic unit AC07X	23
17. Electric diagram of the burner ATMOS A45 - 6-pin connector - model AC07X - (R, R2, sensors TV, TS, TK, TSV)	24
18. Electric wiring diagram connection of D30P, D40P, D50P (D45P), P30, P40, P50 boilers with exhaust fan, model AC07X with 6-pin connector and module AD02 (AD03) - to control exhaust fan of the boiler from burner control unit AC07X (R)	25
19. Electric wiring diagram connection of the boilers D30P, D40P, D50P (D45P), P30, P40, P50 with exhaust fan, model AC07X with 6-pin connector and module AD03 - to control exhaust fan of the boiler and pump in the boiler circuit from burner control unit AC07X (R and R2)	26
20. Electric wiring diagram connection of the boilers DCxxS(X), CxxS(T), ACxxS, KCxxS, DCxxRS with exhaust fan, with 6-pin connector and two modules AD02 - to control exhaust fan of the boiler and pump in the boiler circuit from burner control unit AC07X (R and R2)	27
21. Electric wiring diagram connection of the boilers DCxxS(X), CxxS(T), ACxxS, KCxxS, DCxxRS with exhaust fan, with 6-pin connector and two modules AD02 - to control exhaust fan of the boiler and pump in the boiler circuit from burner control unit AC07X (R and R2)	28
22. Wiring diagram connection of DCxxS(X), CxxS(T), ACxxS, KCxxS, DCxxRS boilers with exhaust fan, model with 6-pin connector and two AD03 modules - to control exhaust fan of the boiler and pump in the boiler circuit from AC07X burner control unit (R and R2) - 3/2017 model	29
23. Commissioning	30
24. Control and setting of the burner	32
Display and control panel	32
Passwords and their functions	33
PARAMETERS menu	34
Setting the required power and combustion quality:	35
INFORMATION menu	59
TESTING menu	60
25. Information - error messages - troubleshooting	61
General troubleshooting	61
Table of error messages on the display - alarms	61
If you are not sure, proceed as follows:	66
If no problem has been found, reset the regulation AC07X by the RESTART command.	67
If the system is working, but you are not satisfied with its function, proceed as follows:	67
26. Maintenance and cleaning of the burner	68
27. List of spare parts - burner A45	70
28. Expanded view of the A45 burner	71
GUARANTEE TERMS	72
RECORD OF INSTALLATION OF THE BOILER AND BURNER	73
ANNUAL INSPECTIONS RECORDS	74
RECORDS OF GUARANTEE PERIOD AND POST-GUARANTEE PERIOD REPAIRS	75

1. General information



WARNING - Before starting the burner you must get thoroughly acquainted with all provisions of this manual. The manufacturer is not liable for damages caused by operation, maintenance or wrong setting of the power of the burner that will cause heat overloading of the burner.

Introduction

This manual is intended for all users and contains information necessary for the installation, start-up, maintenance and safe operation of the burner.

We recommend you to pay great attention to the safety regulations. Interventions that require removal of some parts should be carried out carefully by qualified authorized experts. Repairs and settings that are not described in the manual should not be carried out at all.

Application

The burner is designed for ATMOS boilers: D30P, D40P, D31P, D50P (D45P), P30, P31, P40, P50 and gasification boilers with a modification for installation of a pellet burner into the upper door.

Technical specifications

Name: ATMOS A45

Prescribed fuel: high-quality (white) wooden pellets with the diameter of 6 to 8 mm, length of 5 to 25 mm and calorific value of 16 - 19 MJ.kg⁻¹

Nominal heat input of the burner: 49 kW

Minimum heat input of the burner: 8,5 kW

Maximum heating surface of the boiler that the burner may be installed in: 5 m²

Fuel bin: not part of the delivery - recommended volume 1000 l

Fuel feeding: with an external worm conveyor - not part of the delivery

Burner control: with an AC07X electronic control unit that controls the operation of the external conveyor, two ignition spirals and the fan in accordance with requirements of the boiler and the heating system. The electronic system is protected with the safety thermostat of the boiler, safety thermostat at the pellet supply to the burner, the fan speed transducer and the flame sensing photocell. The operation of the burner is indicated on the electronic control display.

Power supply: 230 V / 50 Hz

Maximum power input at the start with one ignition element: 480 W - normal setting

Maximum power input at the start with two ignition elements: 1042 W - special functions

Average power input at the nominal heat input operation: 47 W

Average power input at the minimum heat input operation: 29 W

Average heat input in the standby mode: 3.3 W

Prescribed fuse protection of the burner with the boiler: 6.3 A

Acoustic pressure level (noisiness): 47 dB

Burner weight: 23 kg

Burner dimensions, WxHxD: 31 x 55 x 66 cm

Minimum dimensions of the combustion chamber: diameter / width = 400 mm, length / depth = 400 mm

Minimum ashpan space of the boiler: must correspond to operation at the nominal output for at least one week. (min. 4 l)

Minimum vacuum in the combustion chamber of the boiler: 2 Pa

Min. protection against inadvertent opening of the boiler chamber (door): with a safety screw (except DxxP)

2. Design

Description

Heating with pellets with the use of the ATMOS A45 pellet burner has a lot in common with natural gas or oil heating. However, there is a difference that burning of pellets produces a certain quantity of ashes that must be removed from the burner and boiler in an interval to avoid impairment of efficiency or affecting the functionality of the burner.

The ATMOS A45 pellet burner is supplied with automatic fuel ignition as standard. The assembly of the burner, external conveyor and fuel bin work completely automatically during operation and is controlled by an electronic control unit with the use of a flame sensor (photocell). In the burner body the fuel and combustion air are supplied in such a way to ensure maximum efficiency and environment-friendliness of fuel burning.

Only high-quality pellets with the diameter of 6 to 8 mm and length of 5 to 25 mm should be fed into the burner. **Pellets made of soft wood without bark, called white pellets, are considered as high quality pellets.**

Ashes are normally removed from the burner through the open door once every 7 to 30 days as necessary. It is recommended to thoroughly clean the inner parts of the burner once a year; for this operation the burner should be removed from the boiler. For ideal cleaning of the combustion chamber (pot) of the burner you can use a special vacuum cleaner or a poker.

The burner consists of the following parts:

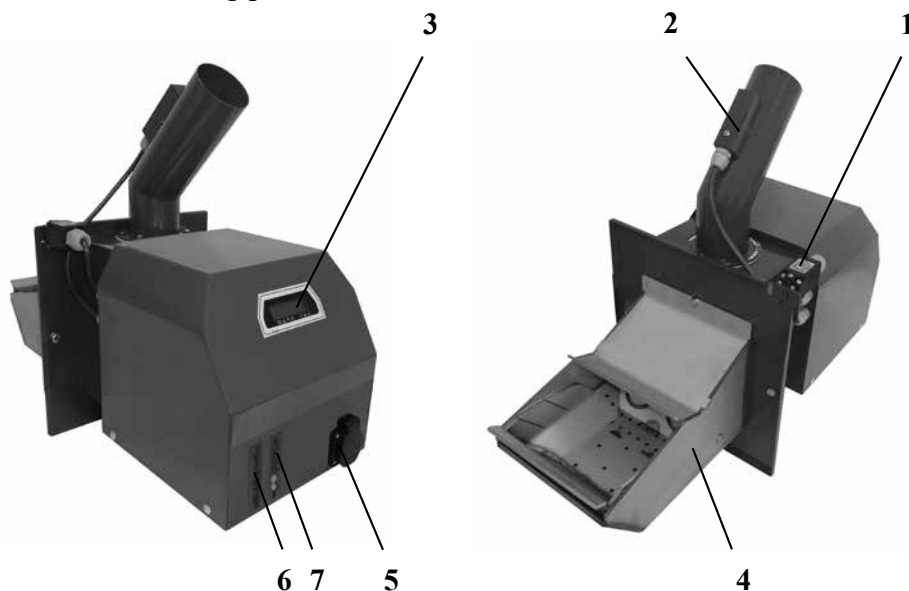

- 1 - End switch
- 2 - Safety thermostat 95 °C
- 3 - Display of the electronic unit of the burner
- 4 - Combustion chamber (mouth) of the burner
- 5 - Socket for the external conveyor
- 6 - connector for interconnection cable between the boiler and the burner (power cable) (L1, L2, N, PE, R a R2)
- 7 - connector for connection of TS, TV, TK and TSV sensors



CAUTION - For the A45 burner DRA50 external shaft conveyors with the length of 1,7, 2,5, 4 and 5m with the diameter of 80 mm are designed or compact set of AZPD (AZPU) tank with DRA25 conveyor.



Fig. 1 - Combustion mouth of the burner

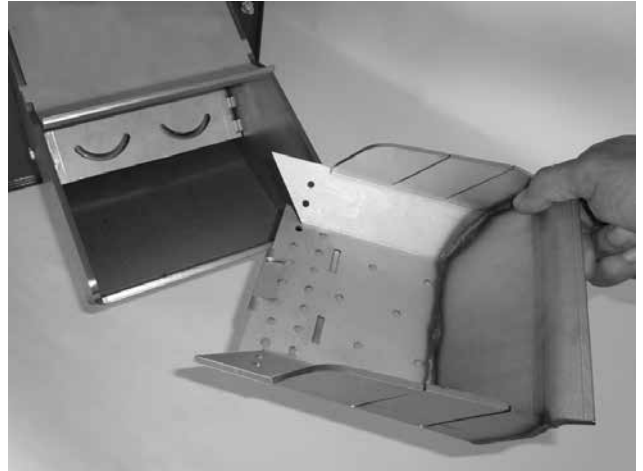

Fig. 2 - Removable combustion chamber - must be regularly cleaned

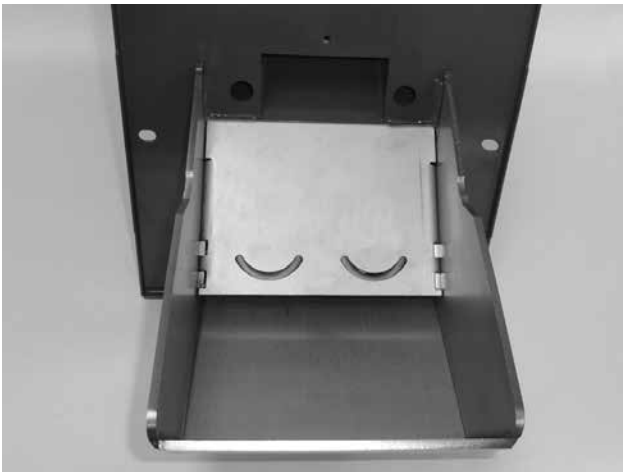

Fig. 3 - Uncovered combustion chamber with openings behind which the ignition spirals are installed



Fig. 4 - Disassembled plate with the ignition spirals

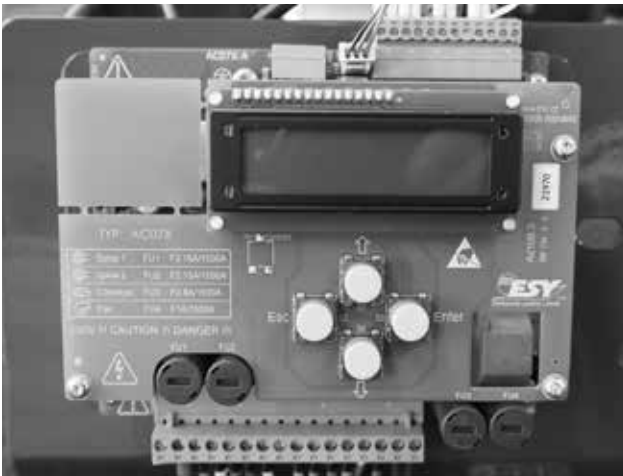

Fig. 5 - Electronic control unit with keys, bottom terminal board (1 - 18), upper distribution frame for connection of TS, TV, TK, TSV sensors and photocells

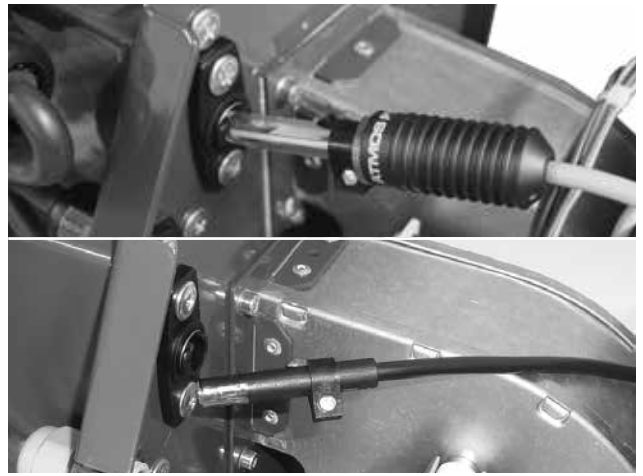

Fig. 4 - Photocell - be careful about its proper orientation - we recommend you to clean it at least once a year

new fotocell/ old fotocell

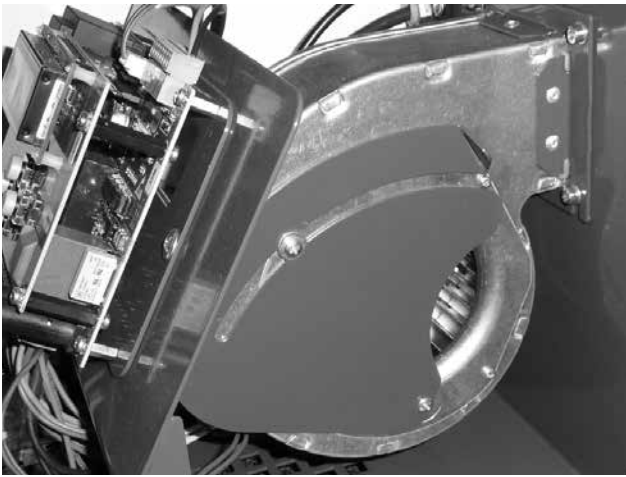

Fig. 7 - Burner fan with an air flap



Fig. 8 - End switch with a special stop

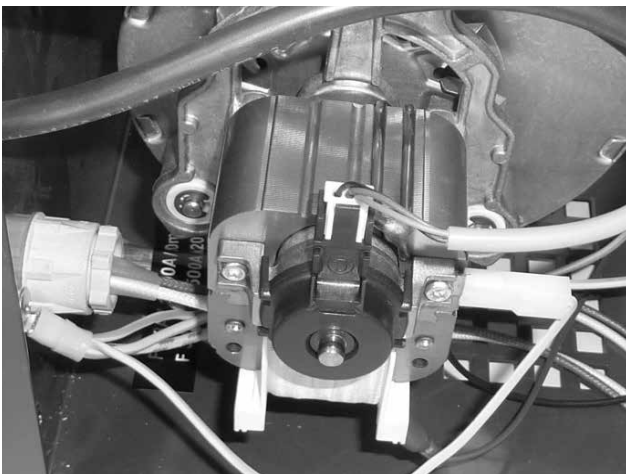

Fig. 9 - Fan speed transducer



Fig. 10 - Safety thermostat on the pellet supply pipe, 95 °C



Fig. 11 - unrifled openings for bushing (may be used for other applications)

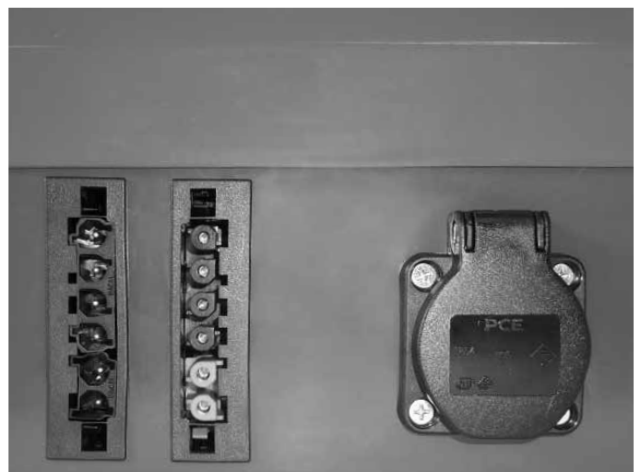

Fig. 12 - Burner with two 6-pin connectors, left - power, right - sensors and socket for conveyor



Fig. 13 – View of the water temperature sensor in the pocket of the accumulation tank (TV and TS)



Fig. 14 – View of the flue gas sensor TS or TSV in the flue gas duct pocket. For boilers D30P, D40P and D50P (D45P) is placed on the flue gas channel



Fig. 15 – View of the water temperature sensor TK in the boiler pocket - boiler with burner in the upper door - DCxxS(X), CxxS, ACxxS, DCxxRS



Fig. 16 – View of the water temperature sensor TK in the boiler pocket, DxxP, Pxx type



Fig. 17 – High-quality wooden pellets – white without black dots (bark)



Fig. 18 – Poor-quality wooden pellets – dark with black dots (with black dots)

3. Burner accessories

Accessory - burner part

Stop for the end switch	1 piece
Bushing for various applications – formerly for TS and TV sensors	2 pieces
Interconnection cable between the boiler and the burner with a connector (6x1.5 mm)	1 piece
Operation and maintenance manual	1 piece
Fuse - type F 3.15A/1500A/5x20mm (ignition spirals)	2 pieces
Fuse - type F 0.8A/1500A/5x20mm (conveyor)	1 piece
Fuse - type F 1.0A/1500A/5x20mm (ventilator)	1 piece

Accessories that are not part of the burner and can be purchased separately:

DRA50 pellet conveyor with the length of 1,7 m and diameter of 80 mm - 40 W	- CODE: H0039
DRA50 pellet conveyor with the length of 2,5 m and diameter of 80 mm - 40 W	- CODE: H0037
DRA50 pellet conveyor with the length of 4 m and diameter of 80 mm - 40 W	- CODE: H0004
DRA50 pellet conveyor with the length of 5 m and diameter of 80 mm - 40 W	- CODE: H0005

Water temperature sensor with a 5 m cable (range - 20 ...+ 110 °C)
- type KTF 20 - CODE: P0431

Flue gas temperature sensor with a 2.5 m cable (range -20 ...+ 300 °C)
- type VFF00-75P65 - CODE: P0414

Pocket for a flue gas sensor to be positioned in the flue gas duct, G1/2“ x 85 mm - CODE: V0524

AD02 module for control of the boiler fan via a reserve output - CODE: P0432

AD03 module for control of the boiler fan and the pump in the boiler circuit (solar) - CODE: P0436

AD04 module for special function of the burner - CODE: P0446

Cavity with tin for extension of conductors (sensors) - CODE: P0445

AS25 set, which consists of two KTF 20 sensors with a 5 m cable, **AD02 module** and a special adapter for DCxxSP(X), CxxSP, ACxxSP boilers - CODE: P0435

AS2012 Set, which consists of two KTF 20 wahter sensors with a 6 m cable, one flue gas (solar) sensor up to 400 °C with a 5 m cable, a pocket for the solar sensor, four cavities with tin for easy connection of conductors, an **AD03 module** and a special adapter for DCxxSP(X), CxxSP, ACxxSP boilers - CODE: P0444

SC2012 Sensor Set, which consists of three KTF 20 wahter sensors with a 6 m cable, one flue gas (solar) sensor with a 5 m cable and a pocket for the solar sensor - CODE: P0437

Special adapter for DCxxSP(X), CxxSP, ACxxSP boiler that enable operation of the exhaust fan of the boiler together with the pellet burner - CODE: S0725

4. Safety, burner installation and commissioning

Safety and connection of the burner to the boiler



WARNING - Before starting the burner you must carefully read all the provisions of this manual. At the same time you must observe all general safety regulations for work with heating equipment resulting from the valid legislation.

- The premises where the equipment will be installed must comply with all fire protection regulations in accordance with valid standards and laws.
- The equipment must be positioned in such a way to ensure access for cleaning and removal of ashes not only from the burner, but also from the boiler, flue gas duct and chimney.
- The burner must be installed to the boiler over a sealing cord, soft Sibral sealing or another insulation and sealing material to prevent flue gas from escaping along the burner to the boiler room. Under one of the nuts with the use of which the burner is attached to the boiler a **SPECIAL SHEET-METAL PART - END SWITCH STOP** must be positioned. It is used to compress the end switch that monitors the proper position of the burner on the boiler. This protective device must not be omitted in any case as it is directly related to fire safety.
- The connection between the burner and the boiler must be properly tightened to prevent flue gas from escaping to the boiler room.
- During the installation you must make sure that the pellets can freely fall through the hose to the burner. The connections between the hose, burner and conveyor must also be properly tightened.

Design and technical measures for increasing safety

- The ignition and combustion process is controlled by **the electronic control unit by means of the flame sensor - photocell**. If the sensor does not sufficiently see the flame during operation, it will automatically put the burner out of operation.
- The electronic control unit **senses the speed of the burner fan** and at any problems of the fan it automatically puts the burner out of operation.
- On the burner frame there is an **end switch and end switch stop** that does not make it possible to start to burner if the burner is not properly fixed to the boiler (e.g. after cleaning of the burner). If during normal operation of the burner the end switch gets disconnected, the burner will be automatically put out of operation. If at the start after two attempts with the fuel supply and one attempt without the fuel supply the pellets are not ignited, the burner will be automatically put out of operation.
- If during normal operation of the burner the fuel bin runs out of pellets, the burner will try a new start and subsequently will be put out of operation. After replenishing pellets in the fuel bin and drawing pellets to the conveyor you can start the burner by merely **turning off and on** the burner switch on the boiler panel.
- The flexible transparent hose between the burner and external conveyor is made of special material that melts at high temperatures and the hose will change to a spring that will separate the burner from the fuel bin.

- **The safety thermostat** - located on the fuel supply pipe of the burner, will shut down the burner if its temperature is higher than 95 °C. Thus, it protects the burner from return ignition of pellets in the conveyor and at the same time from operation with clogged flue gas exhaust from the boiler (e.g. in case of a failure to remove dust from the boiler, flue gas duct and chimney). The safety thermostat will also put the burner out of operation in case the hose between the burner and conveyor gets perforated to prevent flue gas from escaping to the boiler room.



INFO - After any shutdown of the burner when an error message (ALARM) appears on the display it is necessary to immediately find the cause and remove it. After removing the cause of the error you can start the burner by merely **turning off and on the burner switch**, which is located on the boiler panel.

Basic dimensions of the opening for installation of the burner in a boiler

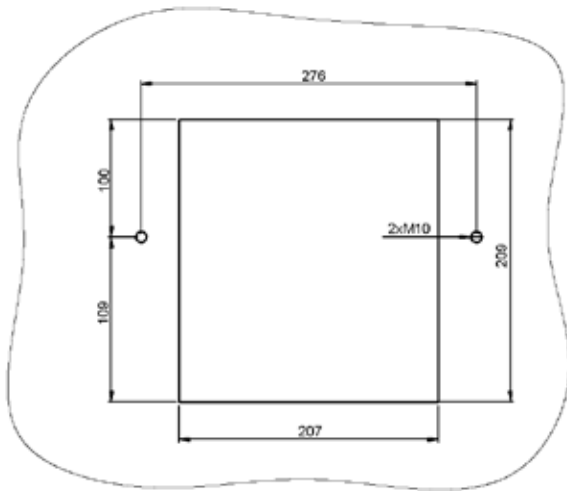

In the case of the D30P, D40P, D50P (D45P), P30, P40, P50 boilers the burner is fastened to the frame of the boiler with sealing cord - 18 x 32 mm.

For boilers with pellet burner in the upper door the Sibral (mineral wool) sealing is used under the burner (code: S0140).

Seating of the burner and lid in the boiler

Pellet boilers
D30P, D40P, D50P (D45P),
P30, P40, P50

Gasification boiler
with modification for a burner in the
upper door

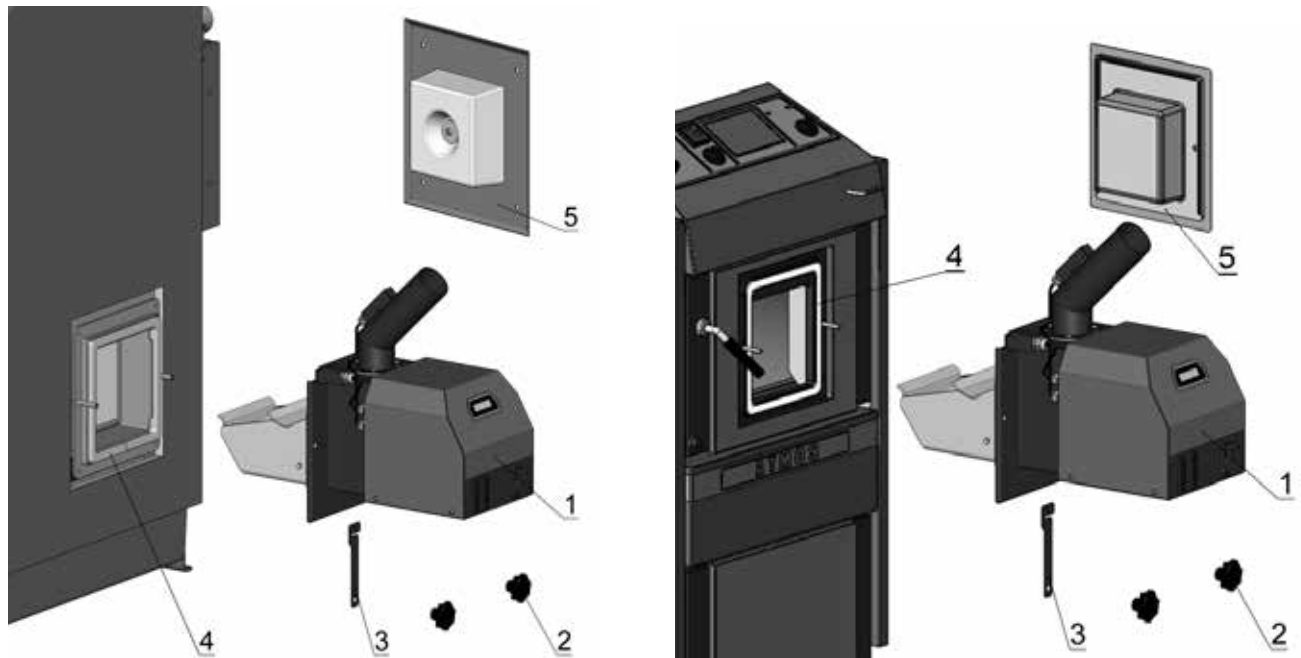

Explanatory notes:

1. A45 burner
2. Decorative nut M10 (screw with decorative nut)
3. End switch stop
4. Sealing
5. Lid with insulation

5. Type of environment and location of the boiler with the burner in the boiler room

Boilers with a pellet burner may be used in the AA5/AB5 basic environment in accordance with the ČSN3320001 standard. Boilers must be installed in a boiler room with guaranteed sufficient supply of combustion air. It is unacceptable to locate boilers on residential premises (incl. corridors). The cross-section of the opening for supply of combustion air to the boiler room must be at least 350 cm² for boilers with an output of 5 - 45 kW.

1. Chimney
2. Flue gas duct
3. Boiler
4. A45 burner
5. External conveyer
6. Bin (500 l)

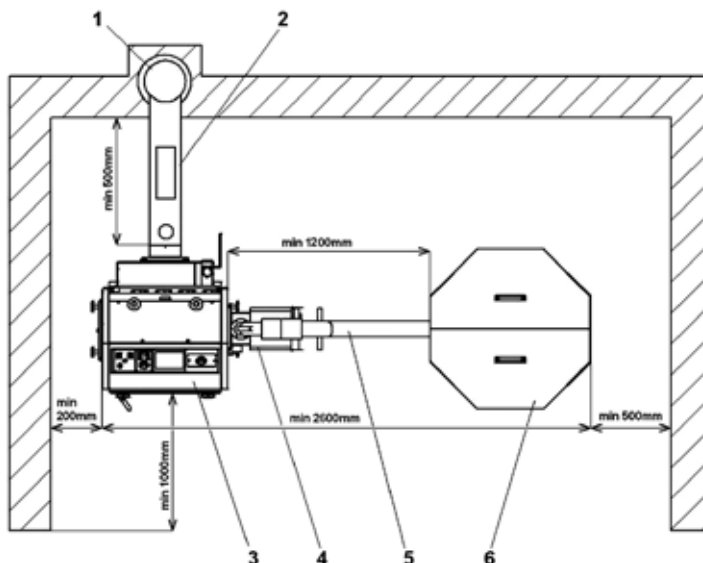

EN

6. Chimney

A boiler with a burner must always be connected to the chimney vent with consent of the responsible chimney maintenance company. The chimney vent must always produce sufficient draught and exhaust flue gas to the free atmosphere in virtually all operation conditions. For proper function of boiler the separate chimney vent must be properly dimensioned **as the combustion, output and service life of the boiler depends on its draught.** The draught of a boiler directly depends on its cross-section, height and roughness of the inner wall. No other device may be connected to the chimney to which a boiler is connected. **The diameter of the chimney must not be smaller than the outlet on the boiler (min. 150 mm).** The chimney draught must achieve prescribed values (see the technical specifications in the boiler manual). However, the boiler must not be excessively high so as not to reduce the efficiency of the boiler and not to disturb its combustion (tear the flame). In case of too strong draught install a throttling flap or draught reducer in the flue gas duct between the boiler and the chimney.

Guideline values of dimensions of the chimney cross-section:

20 x 20 cm	height 7 m
Ø 20 cm	height 8 m
15 x 15cm	height 11 m
Ø 16 cm	height 12 m

The exact determination of chimney dimensions is defined by the ČSN 73 4201 standard.

The prescribed chimney draught is specified in the “Technical data” chapter of the manual of the particular boiler.



CAUTION - The draught of the chimney during operation must ensure the minimum vacuum of 2 Pa in the combustion chamber of the boiler.

7. Flue gas duct of the boiler

The flue gas duct from the boiler must lead to the chimney vent. If the boiler cannot be connected directly to the chimney vent, the corresponding flue gas duct adapter must be as short as possible with regard to the particular conditions, but **not longer than 1 m**, without additional heating surface and **it must rise towards the chimney**. Flue gas ducts must be mechanically strong and leak-proof for flue gas and cleanable inside. Flue gas ducts must not lead through other owners' residential or commercial units. The inner cross-section of the flue gas duct must not be larger than the inner cross-section of the smoke uptake and must not get narrower towards the chimney. The use of smoke elbows is not suitable. Designs of passages of flue gas ducts through structures of flammable materials are defined in Annexes 2 and 3 of ČSN 061008 and are mainly suitable for mobile units, wooden huts, etc.

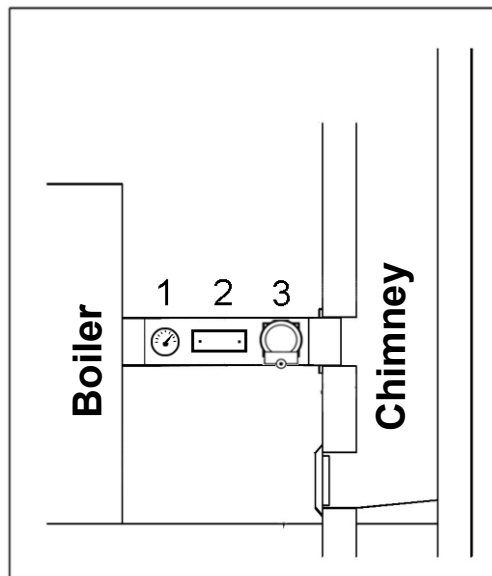

- 1 - Flue gas thermometer
- 2 - Cleaning opening
- 3 - Draught regulator (limiter) / throttling flap



INFO - In case of too strong draught of the chimney install a throttling flap /3/ or a draught reducer in the flue gas duct, see the ATMOS price list.

8. Fire protection within the installation and use of heat appliances

Extract from ČSN 061008 - Fire safety of local appliances and sources of heat

Safe distances

On installation of an appliance the safe distance from building materials must be maintained, at least 200 mm. This distance is valid for boilers and flue gas ducts located near flammable materials of the B, C1 and C2 flammability class (the flammability class is specified in tab. no. 1). The safety distance (200 mm) must be doubled if boilers and flue gas ducts are located near flammable materials of the C3 class (see tab. no.1). The safety distance must be doubled if the flammability class of flammable material is not evidenced. The safety distance may be reduced to a half (100 mm) if you use a non-flammable heat insulating panel (asbestos panel) with the thickness of at least 5 mm, located 25 mm from the protected flammable material (flammable insulation). A shielding panel or protective screen (on the protected object) must exceed the outline of the boilers (incl. flue gas ducts) at each side by at least 150 mm and the top surface of the boiler by at least 300 mm. A shielding panel or protective screen must also be used to protect fixtures of flammable materials if the safe distance cannot be maintained (e.g. in mobile units, huts, etc. - more details in ČSN 061008). The safety distance must also be maintained in case of installation of fixtures near boilers.

If boilers are located on a floor of flammable materials, they must be installed on a non-flammable, heat-insulating pad, exceeding the ground plan at the side of the feeding and ashpan opening by at least 300 mm before the opening - at the other sides by at least 100 mm. As non-flammable, heat insulation pads you can use all materials of the A flammability class.

Tab. nr.1

Flammability classes of building materials and products	
A - no flammability	granite, sandstone, concrete, brick, ceramic tiles, mortar, fire-resistant plastering, etc.
B - difficult flammability	Akumin, Izomin, cemented fibreboard, Lignos, panels of basalt felt, fibreglass panels, Novodur
C1- poor flammability	hardwood (oak, beech), hardboard panels, plywood, Sirkolit, Werzalit, hardened paper (Formica, Ecrona)
C2- medium flammability	softwood (pine, larch, spruce), chipboard and cork panels, rubber flooring (Industrial, Super)
C3- high flammability	Fibreboard panels (Hobra, Sololak, Sololit), cellulose materials, polyurethane, polystyrene, polyethylene, lightened PVC



WARNING - In circumstances leading to the danger of transient ingress of flammable gases or vapours and during work that might result in a temporary risk of a fire or explosion (e.g. gluing of linoleum, PVC, etc.) the boilers must be put out of operation in time before the occurrence of the danger. **No objects of flammable substances may be put on the burner and boiler in a smaller distance than the safe distance from them (more - see ČSN EN 13501-1).**

In short, do not put any items that could easily catch fire in the vicinity of the boiler.

9. Basic connection diagram of a D30P, D40P, D50P (D45P), P30, P40, P50 boiler with an accumulation tank for burner control on the basis of TS and TV sensors

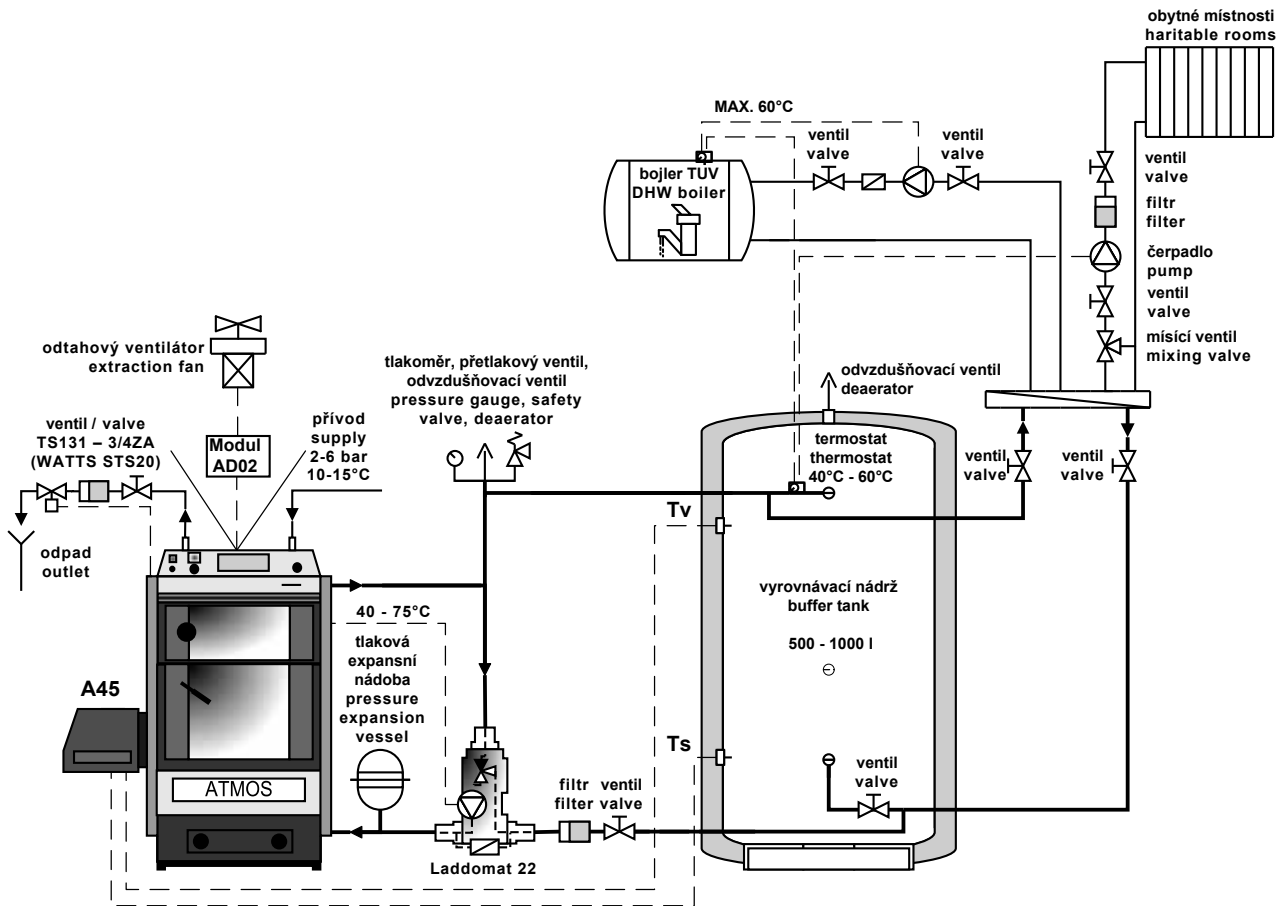

INFO – The TV and TS sensors on the accumulation tank are connected directly to the burner. The AD02 module is inserted under the instrument hood of the boiler and is connected to the terminal board of the boiler (AD02 module - LA clamp), where it controls the exhaust fan of the boiler.

Required accessories (not part of the burner): AD02 (AD03) module and two KTF 20 sensors – part of the boiler delivery

System configuration of parameters: S6 = 4, S14 = 0, S15 = 2

(Reserve R – parameter S6 controls the boiler fan)



WARNING – the AD02 module may be replaced by an AD03 module, whereas only the required output is used (module AD03 – LA clamp)

The pump in the boiler circuit is controlled by the directly installed thermoregulator from the boiler panel.

10. Connection of boilers D30P, D40P, D50P (D45P), P30, P40, P50 with an accumulation tank for burner control on the basis of TS and TV sensors and control of the boiler pump on the basis of the TK sensor

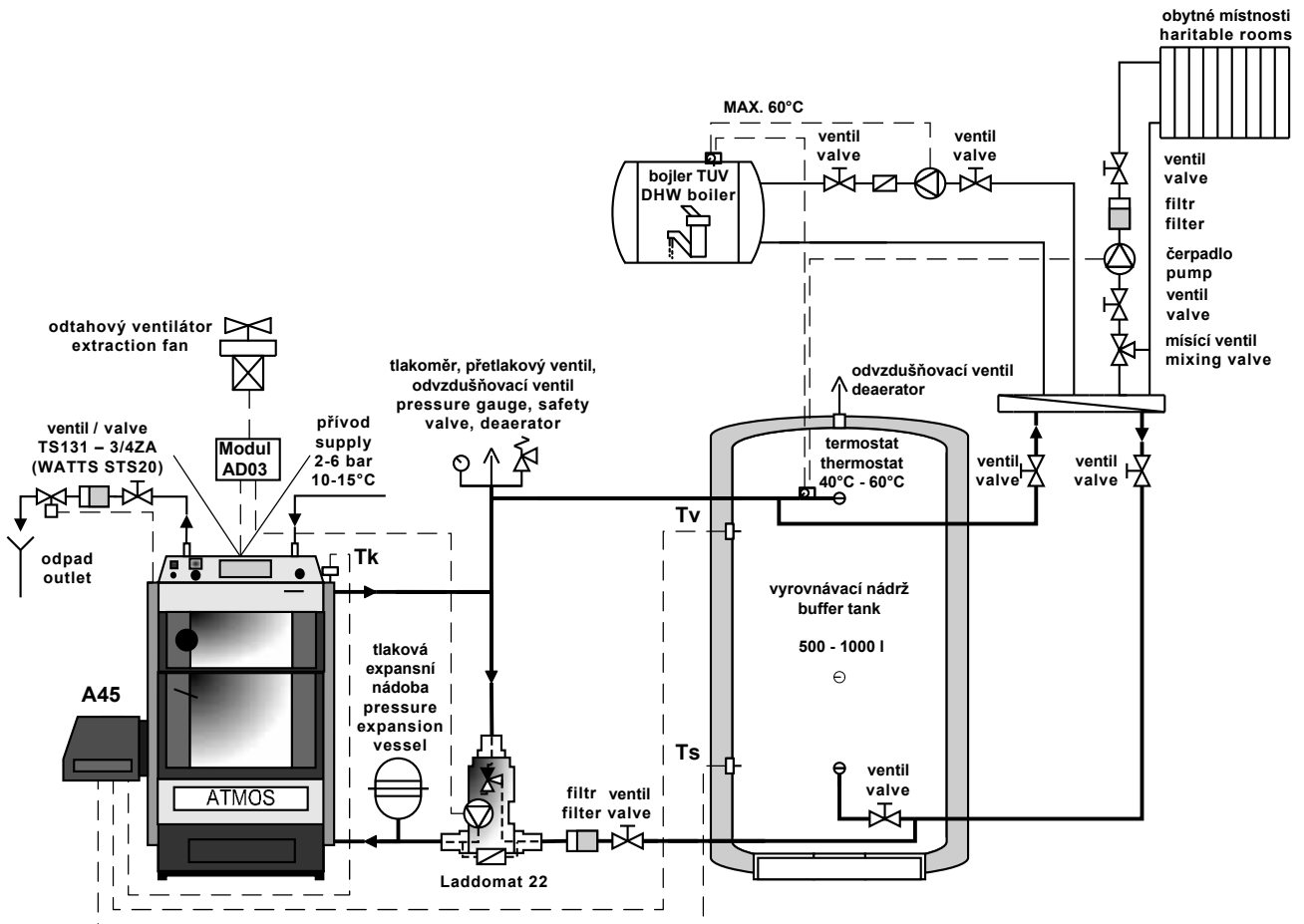

INFO – The TV and TS sensors on the accumulation tank and the TK sensor on the boiler are connected directly to the burner. The AD03 module is inserted under the instrument hood of the boiler and is connected to the terminal board of the boiler (AD03 module - Lc clamp – pump, LA clamp - fan), where it controls the exhaust fan and pump in the boiler circuit.

Required accessories (not part of the burner): AD03 module and three KTF 20 sensors – part of the boiler delivery

System configuration of parameters: S6 = 4, S14 = 13, S15 = 2

(reserve R – parameter S6 controls the boiler fan, reserve R2 – parameter S14 controls the boiler pump)

11. Connection of boilers D30P, D40P, D50P (D45P), P30, P40, P50 with an accumulation tank with solar heating for burner control on the basis of TS, TK and TV sensors (automatic sensor switching function), function of controlling the solar pump based on TSV and TS temperatures

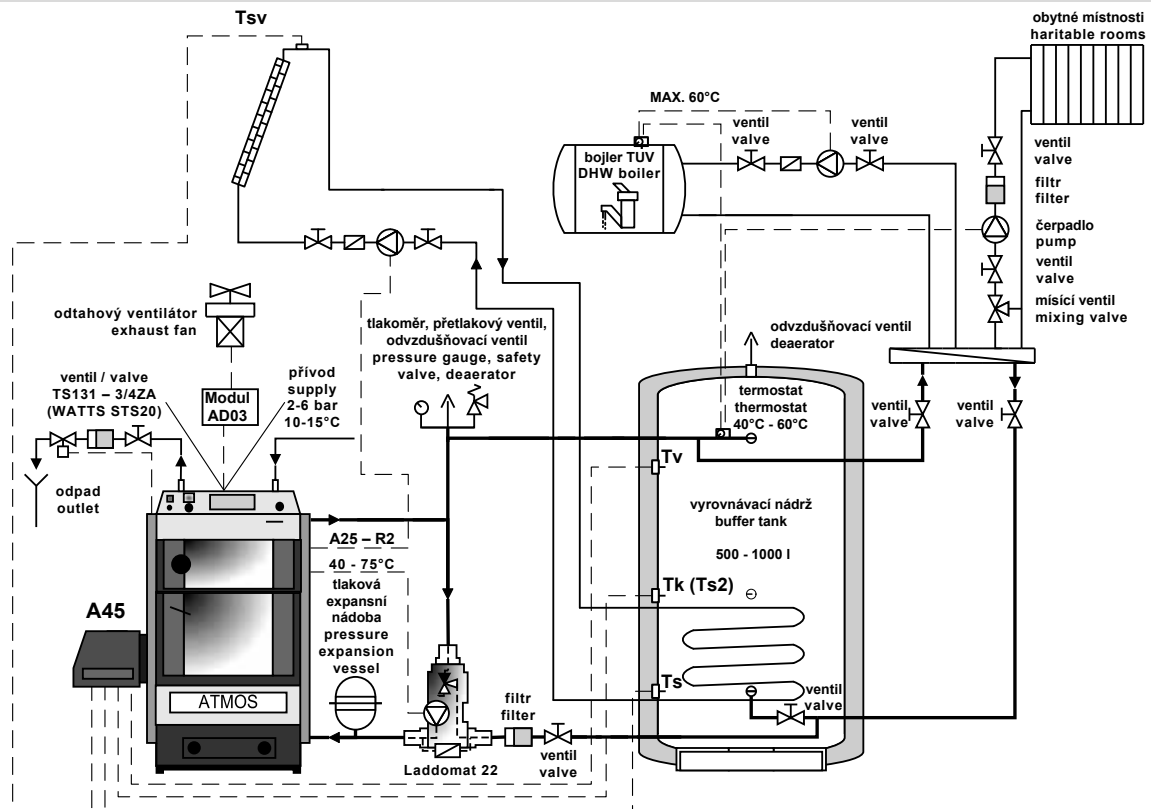

INFO - The TV, TK and TS sensors on the accumulation tank with solar heating, TSV temperature sensor located in the solar panel, all connected directly to the burner. The AD02 (AD03) module is inserted under the instrument hood of the boiler and is connected to the terminal board of the boiler (AD02 module - LA clamp), where it controls the exhaust fan of the boiler (reserve R).

The solar pump is electrically connected directly to the terminal board of the boiler, where it is controlled directly from the boiler through the R2 reserve.

Required accessories (not part of the burner): module AD03, three KTF 20 sensors – part of the boiler delivery, AGF2 solar panel sensor (TSV) with pocket up to 400 °C or T7425B1011 up to 300 °C - must be purchased

System configuration of parameters: S6 = 4, S14 = 14, S15 = 3

(reserve R – parameter S6 controls the fan, reserve R2 – parameter S14 controls the solar pump)



WARNING – the AD02 module may be replaced by an AD03 module, whereas only the required output is used (module AD02 or AD03 – LA clamp). Instead of, connect the TK (Ts2) sensor located above the solar exchanger in the buffer (accumulation) tank (see diagram).

Pump in the boiler circuit is controlled via the directly installed thermoregulator from the boiler panel.

12. Connection of boilers D30P, D40P, D50P (D45P), P30, P40, P50 with electronic regulation ACD 03 and accumulation tank with solar heating

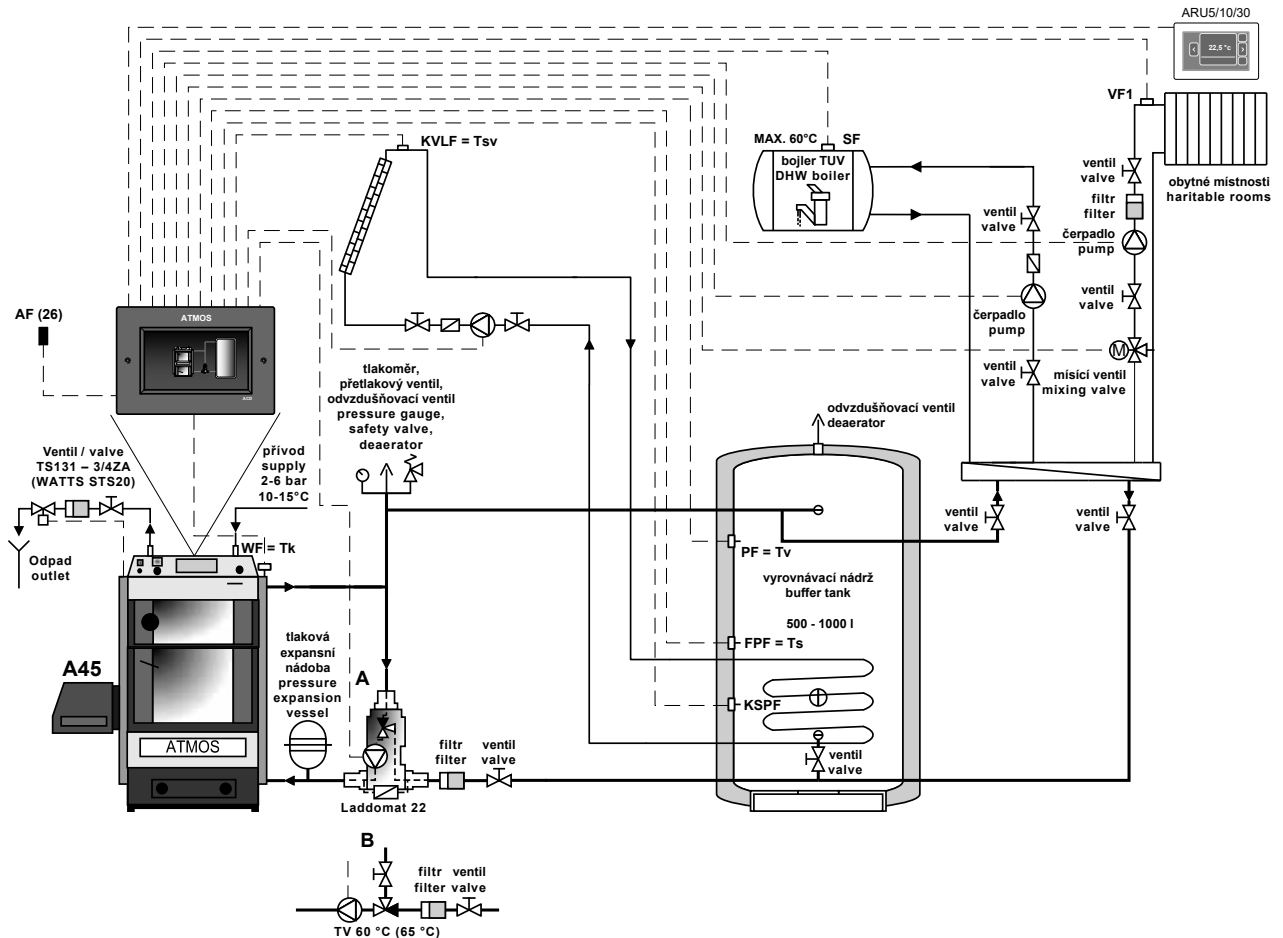

INFO - If using electronic regulation ACD 03/04, we do not connect any set or other sensors in the boiler.

The operation of the burner and fan is controlled directly from the ACD 03/04 regulation.

System configuration of parameters: S6 = 1, S14 = 0, S15 = 1

13. Connection of boilers DCxxS(X), CxxS(T), ACxxS, KCxxS, DCxxRS with built-in burner in upper doors with accumulation tank for regulation of the burner based on sensors TS and TV and control of boiler pump based on TK sensor

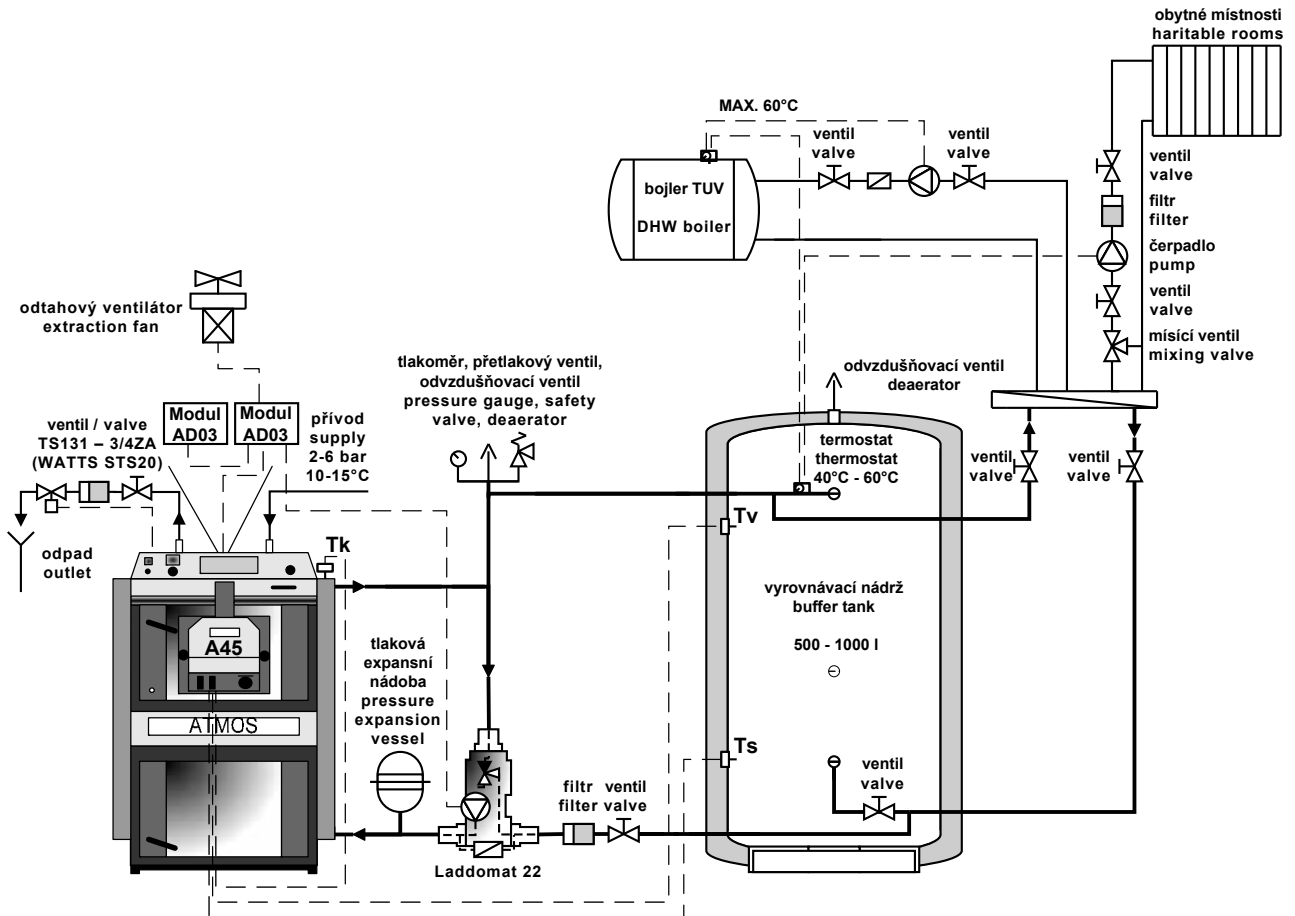

INFO - Boilers with modification for the pellet burner are from 1st of March equipped from the production with two AD03 modules, changeover switch (I/0/II), boiler temperature sensor TK (KTF 20), pump thermostat - 70 °C and with the outlet for the pump in boiler circuit.

The TK sensor placed in boiler pocket (from production), sensors TV and TS (boiler accessory from 1.3.2019) on the accumulation tank, all connected directly to the burner. The (2x AD03) modules are inserted under the instrument hood of the boiler and is connected to the terminal board of the boiler. Both AD03 modules control the exhaust fan of the boiler and the pump in the boiler circuit.

Boilers version 2016 has only one module AD02 to control exhaust fan.

Required accessories (not part of the burner): nothing needs to be bought

For boilers version 2016 is necessary to buy two KTF 20 sensors (TV and TS sensores)

System configuration of parameters: S6 = 4, S14 = 13, S15 = 2

(reserve R - parameter S6 controls the boiler fan, reserve R2 - parameter S14 controls the boiler pump)



WARNING – for boilers with a burner built in the upper doors, it is not possible to use the function of controlling solar heating directly from the pellet burner

14. Connection of boilers DCxxS(X), CxxS(T), ACxxS, KCxxS, DCxxRS with built-in burner in upper doors and with ACD 03/04 electronic regulation

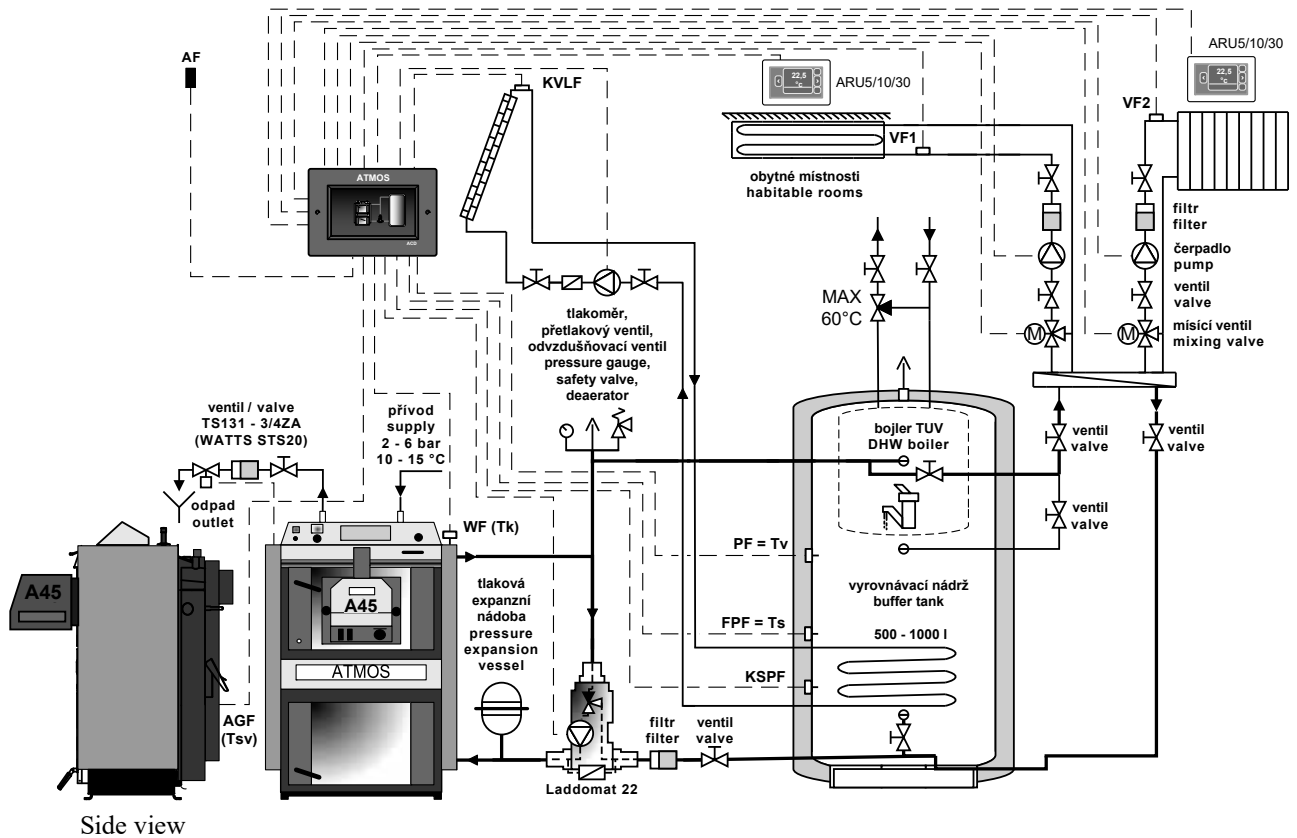

INFO - If using electronic regulation ACD 03/04, we do not connect any set or other sensors in the boiler.

The operation of the burner, solar and fan is controlled directly from the ACD 03/04 regulation.

System configuration of parameters: S6 = 1, S14 = 0, S15 = 1

15. Connection of the boiler and burner to the electric mains

Only connect the burner to the 230 V, 50 Hz electric mains **via the boiler** with a mains cable without a plug so that the conductors (L, N) should not be interchanged. The mains supply must be replaced with the same type by a repair organization. The boiler must be positioned in such a way that the connector on the burner can be within the operator's reach (in accordance with ČSN EN 60335-1).



CAUTION - Boilers with a burner may only be connected by a qualified person in accordance with all the relevant valid regulations of the particular country while great attention must be paid to safe earthing of the boiler.

After the installation of the burner on the boiler the technician must connect the burner and subsequently the entire boiler to the electric mains in accordance with the attached wiring diagram.

Connection:

Between the burner and boiler a six-wire cable is newly used that is connected with one end to the burner with a 6-pin connector (part of the burner) and the other end with a 6-pin connector to the boiler.

The meaning of the conductors is as follows:

- **Black – phase L1** (230 V/50 Hz) – with the main switch of the boiler on the black conductor is permanently live (independently of the control thermostat of the boiler). It is the supply voltage of the burner. This phase must be fuse protected via the safety thermostat of the boiler (95 - 110 °C).
- **Brown – phase L2** (230 V/50 Hz) – the brown conductor is controlled by the control or another thermostat on the boiler panel. It brings the phase, impulse for the burner start. It is perceived as the starting (ignition) and shutdown signal. This phase must also be fuse protected via the safety thermostat of the boiler. (95 – 110 °C).
- **Grey - reserve R (L3)** (230 V/50 Hz) - the grey conductor is connected to the free place on the boiler terminal board in the case of the boiler version with the 4-pin connector or directly to the 5-pin connector on the boiler. It serves as a reserve conductor for various functions of the boiler, characterized with the S6 parameter. If you do not use the reserve function, connect the supply cable directly to the connector, not connecting or cutting off the grey cable
- **Red - reserve R2** (230 V/50 Hz) – the red conductor is connected directly to the 6-pin connector on the boiler. It serves as the second free reserve for various functions of the boiler, characterized with the S14 parameter. If you do not use the reserve function, do not connect or cut off the red cable.
- **Blue - N** – Neutral – the blue conductor is connected to the neutral conductor.
- **Yellow and green - PE** – Protective Earthing – the yellow and green conductor is connected to the earth.

16. Connection diagram of the electronic unit AC07X

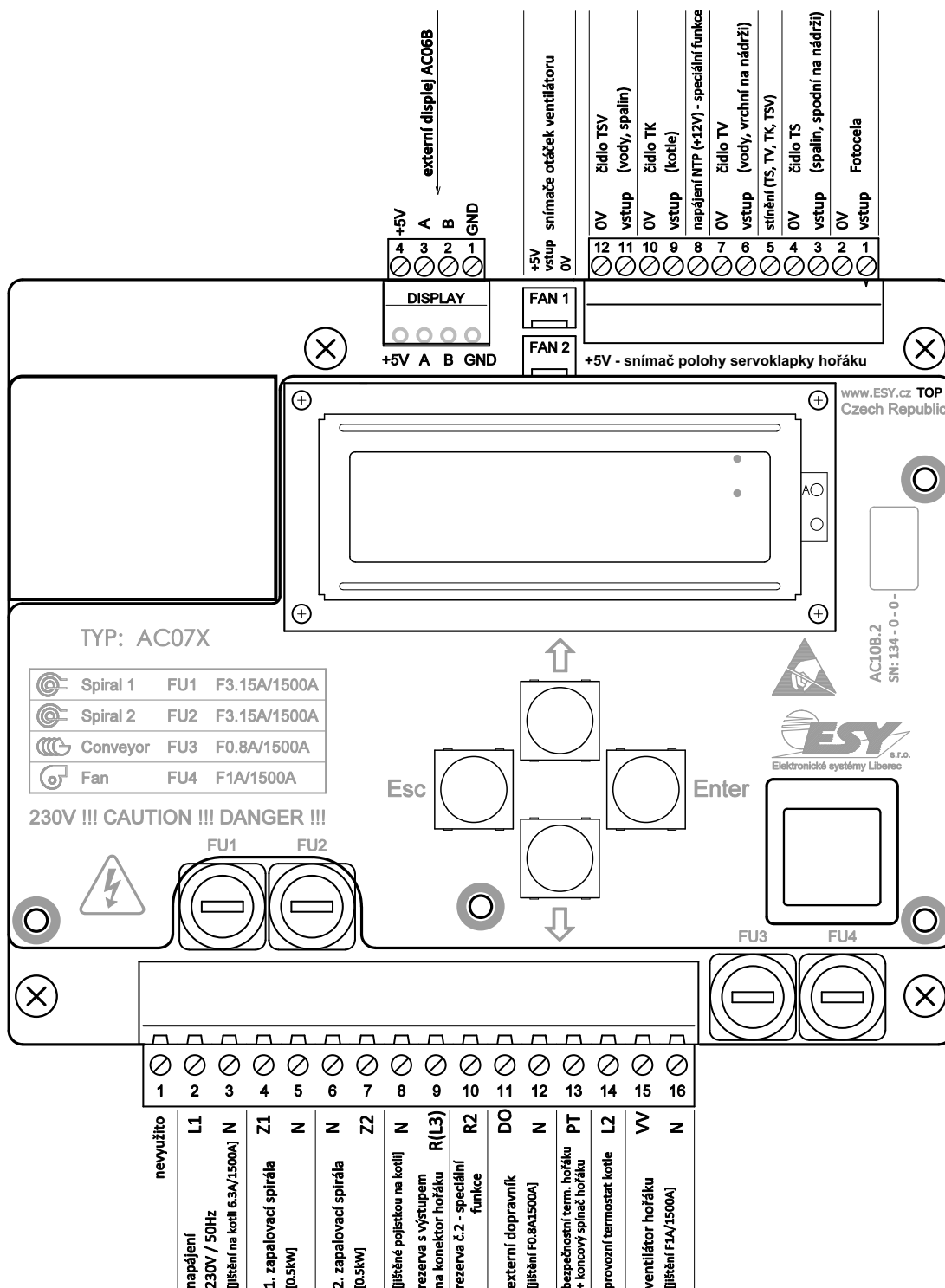

CAUTION - For the connection of the TS, TV, TK and TSV sensors the connection of individual wires is not decisive (can be interchanged). The TS, TV, TK and TSV sensors are not part of the delivery, they must be purchased additionally within the set or separately, Under the AC07X electronic control unit system there is a potentiometer for setting the display contrast; however, we do not recommend you to change its setting.

17. Electric diagram of the burner ATMOS A45 - 6-pin connector - model AC07X - (R, R2, sensors TV, TS, TK, TSV)

EN

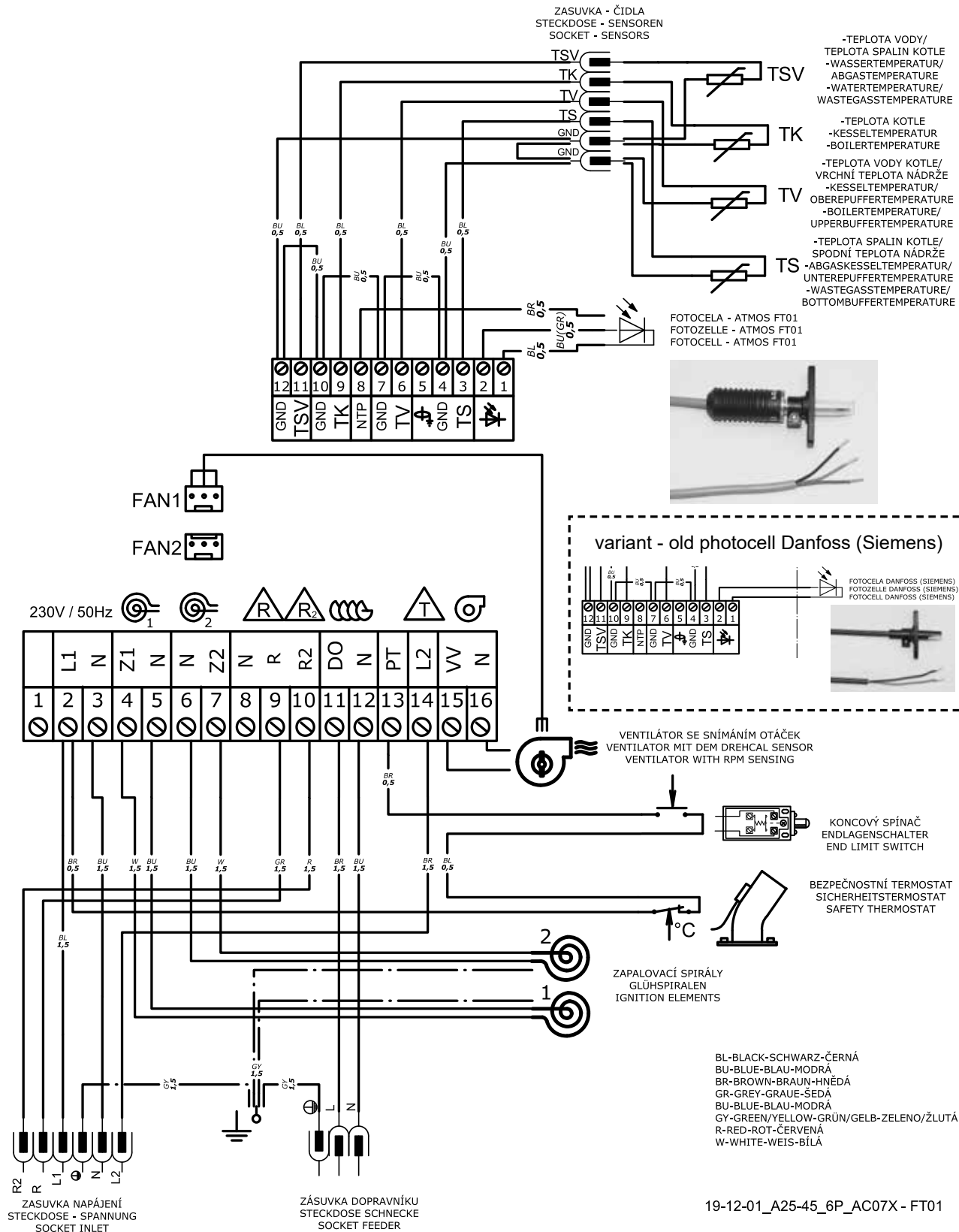

18. Electric wiring diagram connection of D30P, D40P, D50P (D45P), P30, P40, P50 boilers with exhaust fan, model AC07X with 6-pin connector and module AD02 (AD03) - to control exhaust fan of the boiler from burner control unit AC07X (R)

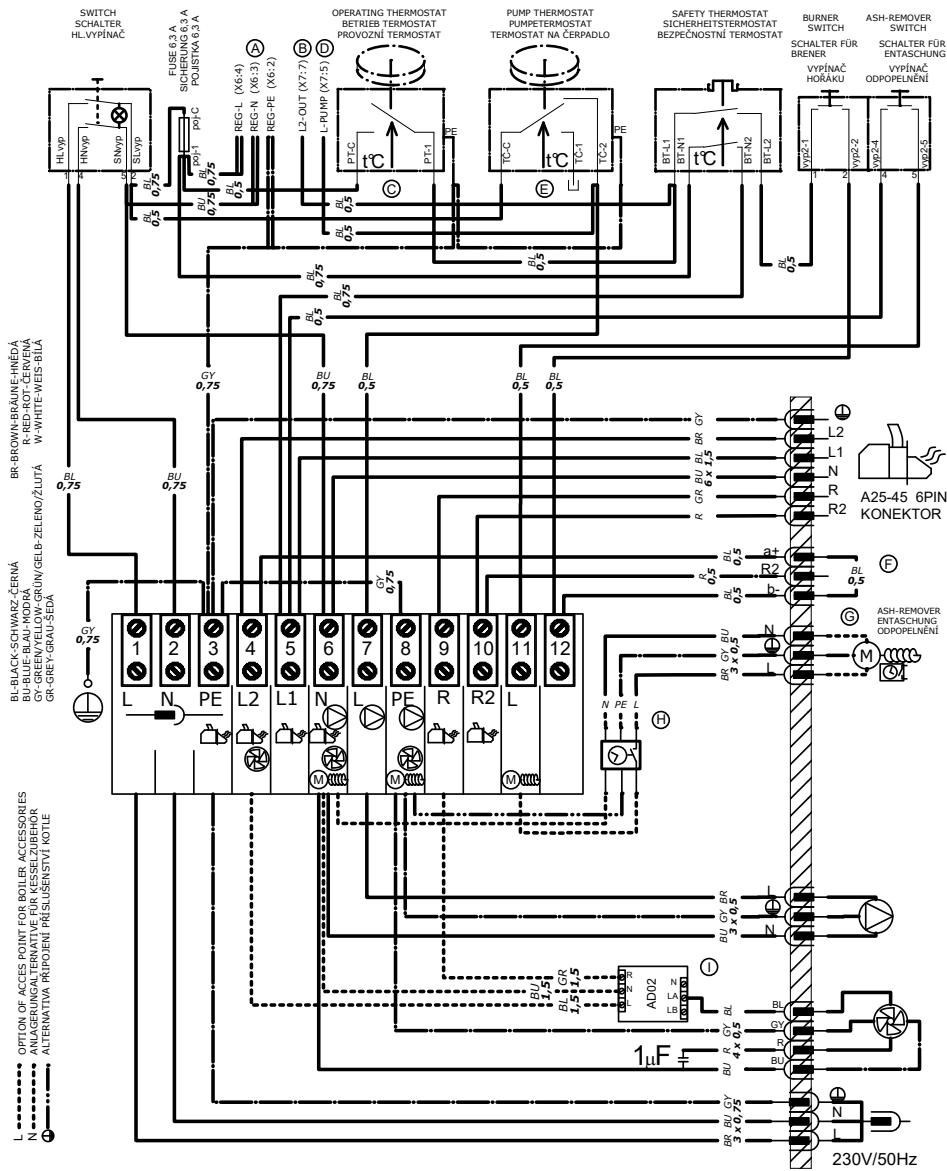

**WHEN USE ELECTRONIC REGULATION ACC01 AND PELLETBURNER A25-45 MUST BE THESE CHANGES OF WIRING:
BEI DER STEUERUNG DES KESSELBETRIEBES DER ELEKTRONISCHE REGELUNG ACC01 UND PELLETBRENNER A25-45 MÜSSEN DIESE ÄNDERUNGEN MACHEN SEIN:
PŘI ZAPOJENÍ ELEKTRONICKÉ REGULACE ACC01 A PELETOVÉHO HOŘÁKU A25-45 PROVEDTE TYTO ZMĚNY:**

- A** VARIANTS OF RESERVOIR POINTS "REG L,N,PE" (FERRULE/FASTON 6,3) FOR ELECTRONIC REGULATION "SPEISEKLEMMEN-VARIANTEN "REG L,N,PE" (ADRENDHÜLS/FASTON 6,3) FÜR ELEKTRONISCHE REGELUNG VARIANTY NÁPAJEČÍCH SVORK "REG L,N,PE" (DUTINKA/FASTON 6,3) PRO ELEKTRONICKOU REGULACI
- B** RESERVOIR POINT "L2 OUT" OF BURNER AND FAN TO THE ELECTRONIC REGULATION (ACC01) SPEISEKLEMME "L2 OUT" DER BRENNER UND VENTILATOR FÜR DIE ELEKTRONISCHE REGELUNG (ACC01) PŘIPOJOVACÍ SVORKA "L2 OUT" HOŘÁKU A VENTILÁTORU DO ELEKTRONICKÉ REGULACE (ACC01)
- C** WHEN ELECTRONIC REGULATION CONTROL BURNER - CONNECTORS "PT-C" AND "PT-1" MUST BE UNCONNECT DEN KONNEKTÖREN "PT-C" AND "PT-1" ABKLEMMEN BEI DER BRENNERBEDIENUNG DER ELEKTRONISCHE REGELUNG KONNEKTORY "PT-C" A "PT-1" ODPOJIT PŘI OVLÁDÁNÍ HOŘÁKU ELEKTRONICKOU REGULACI
- D** RESERVOIR POINT "L PUMP" OF BOILER PUMP TO THE ELECTRONIC REGULATION (ACC01) SPEISEKLEMME "L PUMP" DER KESSELPUMPE FÜR DIE ELEKTRONISCHE REGELUNG (ACC01) PŘIPOJOVACÍ SVORKA "L PUMP" KOTLOVÉHO ČERPADLA DO ELEKTRONICKÉ REGULACE (ACC01)
- E** WHEN ELECTRONIC REGULATION CONTROL BOILER PUMP - CONNECTORS "TC-C" AND "TC-2" MUST BE UNCONNECT DEN KONNEKTÖREN "TC-C" AND "TC-2" ABKLEMMEN BEI DER KESSELPUMPEBEDIENUNG DER ELEKTRONISCHE REGELUNG KONNEKTORY "TC-C" A "TC-2" ODPOJIT PŘI OVLÁDÁNÍ KOTLOVÉHO ČERPADLA ELEKTRONICKOU REGULACI
- F** ACCESS POINT FOR EXTERNAL BOILER REGULATION - PLUG IN CONNECTOR ANLAGERUNG FÜR EXTERN KESSELREGELUNG - KLEMME IN DEN KONNEKTOR PŘIPOJOVACÍ SVORKY PRO EXTERNÍ REGULACI KOTLE - KLEMA V KONNEKTORU
- G** CONNECTOR (BLACK/RED) - FOR EXAMPLE RESERVOIS POINT FOR MODUL AD01 - MOTOR OF ASH-REMOVER KONNEKTOR (SCHWARZ/ROT) - ZUM BEISPIEL FÜR DEN MODUL AD01 - ENTSCHÜNGMOTOR KONNEKTOR (ČERNO ČERVENÝ) - NAPŘÍKLAD PRO MODUL AD01 - MOTOR ODPOPELNĚNÍ
- H** ACCESS POINTS - FOR EXAMPLE FOR MODUL AD01 - TIMEUNIT OF ASH-REMOVER SPEISEKLEMME - ZUM BEISPELE FÜR MODUL AD01 - ZEITBEDIENUNG FÜR DEN ENTSCHÜNG PŘIPOJENÍ - NAPŘÍKLAD PRO MODUL AD01 - ČASOVÝ MODUL ODPOPELNĚNÍ
- I** NO WITH ACC01 - MODUL AD02 FOR BOLLERFAN CONTROL FROM BURNER A25/45 NEPLATÍ S ACC01 - MODUL AD02 K OVLÁDÁNÍ VENTILÁTORU KOTLE HOŘÁKEM A25/45

D20-45P_11-05-01_A25-45_6P_1AD02

19. Electric wiring diagram connection of the boilers D30P, D40P, D50P (D45P), P30, P40, P50 with exhaust fan, model AC07X with 6-pin connector and module AD03 - to control exhaust fan of the boiler and pump in the boiler circuit from burner control unit AC07X (R and R2)

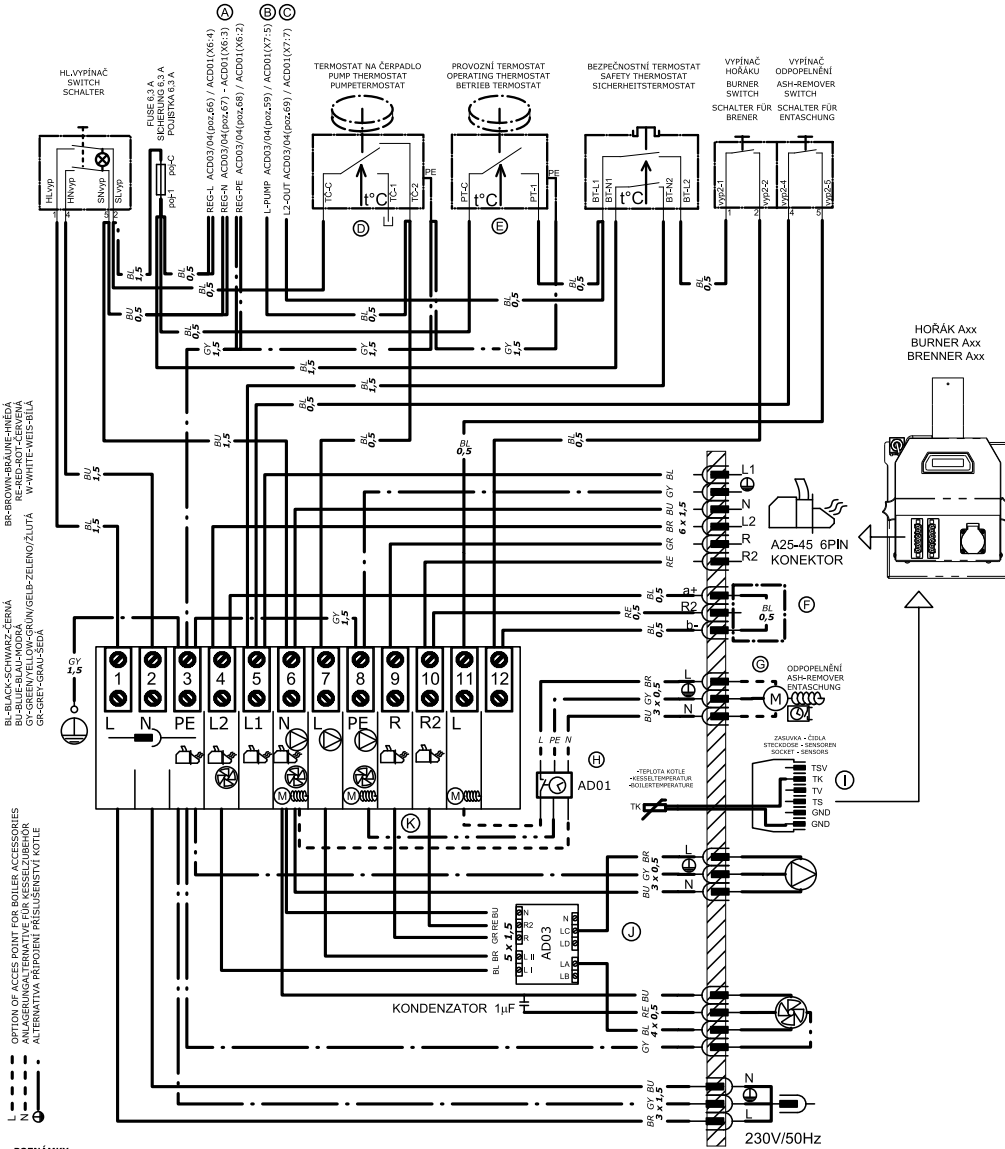

POZNÁMKY:
NOTES:

- A** VARIÁNTY NAPÁJECÍCH SVOREK "REG L,N,PE" (DUTINKA/FASTON 6.3) PRO ELEKTRONICKOU REGULACI
VARIANTS OF RESERVOIR POINTS "REG L,N,PE" (FERRELL/FASTON 6.3) FOR ELECTRONIC REGULATION
- B** PŘÍPOJOVACÍ SVORKA "L PUMP" KOTLOVÉHO ČERPADLA DO ELEKTRONICKÉ REGULACE
RESERVOIR POINT "L PUMP" OF BOILER PUMP TO THE ELECTRONIC REGULATION
- C** PŘÍPOJOVACÍ SVORKA "L2 OUT" HOŘÁKU A VENTILÁTORU DO ELEKTRONICKÉ REGULACE
RESERVOIR POINT "L2 OUT" OF BURNER AND FAN TO THE ELECTRONIC REGULATION
- D** KONEKTORY "TČ-C" A "TČ-2" ODPOJIT PŘI OVLÁDÁNÍ KOTLOVÉHO ČERPADLA ELEKTRONICKOU REGULACÍ
WHEN ELECTRONIC REGULATION CONTROL BOILER PUMP - CONNECTORS "TČ-C" AND "TČ-2" MUST BE UNCONNECT
- E** KONEKTORY "PT-C" A "PT-1" ODPOJIT PŘI OVLÁDÁNÍ HOŘÁKU ELEKTRONICKOU REGULACÍ
WHEN ELECTRONIC REGULATION CONTROL BURNER - CONNECTORS "PT-C" AND "PT-1" MUST BE UNCONNECT
- F** PŘÍPOJOVACÍ SVORKY PRO ALTERNATIVNÍ EXTERNÍ REGULACI KOTLE - KLEMA V KONEKTORU
ACCESS POINT FOR ALTERNATIVE EXTERNAL BOILERREGULATION - CONNECTOR WITH PLUG
- G** KONEKTOR (ČERNO ČERVENÝ) - NAPŘÍKLAD PRO MODUL AD01 - MOTOR ODPOPELŇENÍ
CONNECTOR (BLACK/RED) - FOR EXAMPLE RESERVOIS POINT FOR MODUL AD01 - MOTOR OF ASH-REMOVER
- H** VOLITELNÉ PŘÍSLUŠENSTVÍ - MODUL AD01 - ČASOVÝ MODUL ODPOPELŇENÍ - PROPOJENÍ S MOTOREM ODPOPELŇENÍ
OPTIONAL ACCESSORIES - MODUL AD01 - TIMEUNIT OF ASH-REMOVER - CONNECTED TO THE ASH REMOVAL MOTOR PILOT CABLE INTO THE RED/BLACK 3P CONNECTOR
- I** ČIDLO "TK" PRO HOŘÁK A25
SENSOR "TK" FOR BURNER A25
- J** MODUL AD03 A OVLÁDÁNÍ ČERPADLA A VENTILÁTORU KOTLE HOŘÁKEM A25/45
MODUL AD03 FOR CONTROL BOILERPUMP AND BOILERFAN FROM BURNER A25/45
- K** VODIČE "R,R2" ODPOJIT Z poz.9,10 PŘI OVLÁDÁNÍ VENTILÁTORU A ČERPADLA KOTLE ELEKTRONICKOU REGULACÍ
WHEN ELECTRONIC REGULATION OF EXHAUST FAN AND PUMP - CABLES "R,R2" MUST BE UNCONNECT FROM poz.9,10

20-10-01_L_D20-50P-A25-45_6P_AD03.5ch

20. Electric wiring diagram connection of the boilers DCxxS(X), CxxS(T), ACxxS, KCxxS, DCxxRS with exhaust fan, with 6-pin connector and two modules AD02 - to control exhaust fan of the boiler and pump in the boiler circuit from burner control unit AC07X (R and R2)

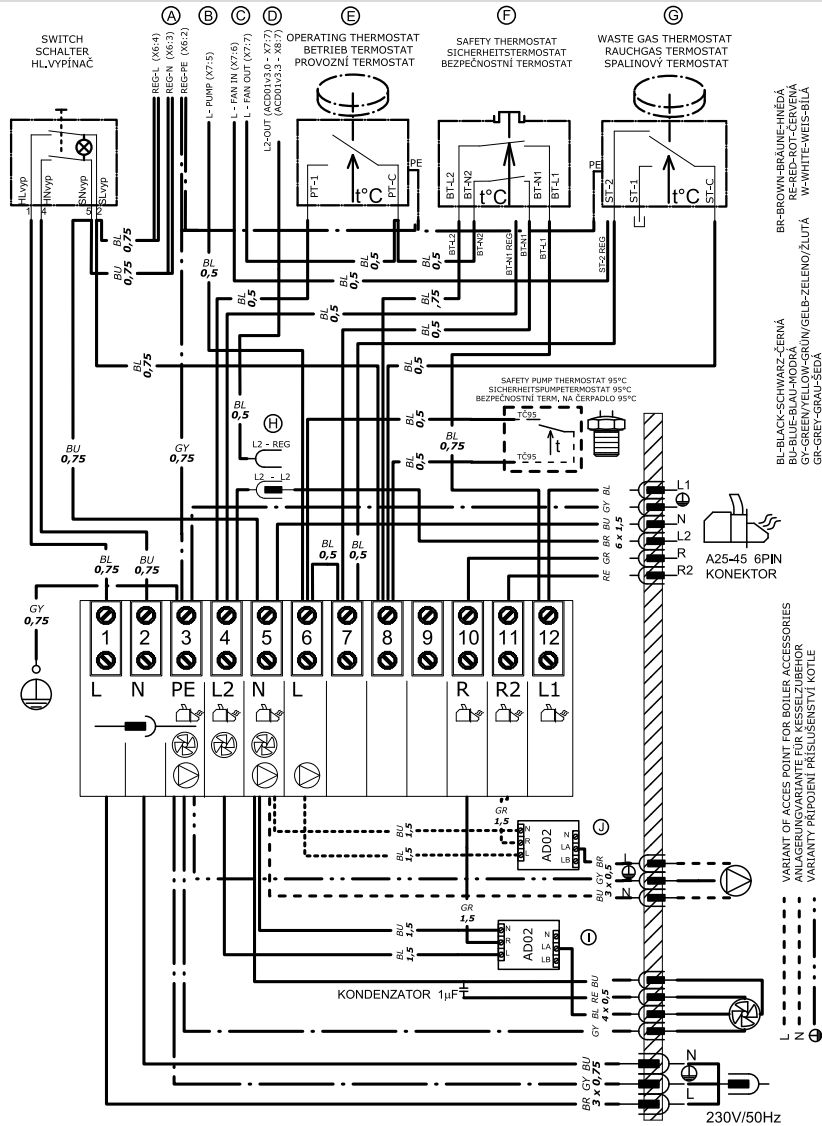

WHEN USE ELECTRONIC REGULATION ACCD01 AND PELLETSBURNER A25-45 MUST BE THESE CHANGES OF WIRING:
 BEI DER STEUERUNG DES KESSELBETRIEBES DER ELEKTRONISCHE REGELUNG ACCD01 UND PELLETSBURNER A25-45 MÜSSEN DIESE ÄNDERUNGEN MACHEN SEIN:
 PŘI ZAPOJENÍ ELEKTRONICKÉ REGULACE ACCD01 A PELETŮVÉHO HOŘÁKU A25-45 PŘEVEDTE TYTO ZMĚNY:

- (A) VARIANTS OF RESERVOIR POINTS "REG L,N,PE" (FERRULE/FASTON 6,3) FOR ELECTRONIC REGULATION
 SPEISEKLEMMEN/ARIANTEN "REG L,N,PE" (ADERENDHÜLSE/FASTON 6,3) FÜR ELEKTRONISCHE REGELUNG
 VARIANTY NÁPĚJÍCH SVOREK "REG L,N,PE" (DUTINKA/FASTON 6,3) PRO ELEKTRONICKOU REGULACI
- (B) RESERVOIR POINT "L-PUMP" OF BOILERPUMP TO THE ELECTRONIC REGULATION
 SPEISEKLEMME "L-PUMP" DER KESSELPUMPE FÜR DIE ELEKTRONISCHE REGELUNG
 PŘIPOJOVACÍ SVORKA "L-PUMP" KOTLOVÉHO ČERPADLA DO ELEKTRONICKÉ REGULACE
- (C) RESERVOIR POINT "L - FAN IN" AND "L - FAN OUT" OF BOILER FAN TO THE ELECTRONIC REGULATION
 SPEISEKLEMME "L - FAN IN" UND "L - FAN OUT" DER KESSELGEBLÄSE FÜR DIE ELEKTRONISCHE REGELUNG
 PŘIPOJOVACÍ SVORKA "L - FAN IN" A "L - FAN OUT" KOTLOVÉHO VENTILÁTORU DO ELEKTRONICKÉ REGULACE
- (D) RESERVOIR POINT "L2" OF BURNER TO THE ELECTRONIC REGULATION (BY THE SOFTWARE VERSION OF ACCD01)
 SPEISEKLEMME "L2" DER BRENNER FÜR DIE ELEKTRONISCHE REGELUNG (GEMÄß SOFTWARE VERSION ACCD01)
 PŘIPOJOVACÍ SVORKA "L2" HOŘÁKU DO ELEKTRONICKÉ REGULACE (PODLE VERZE SOFTWARE ACCD01)
- (E) WHEN ELECTRONIC REGULATION CONTROL BOILER FAN/BURNER - CONNECTORS "PT-C" AND "PT-1" MUST BE UNCONNECT
 DEN KONNEKTOREN "PT-C" UND "PT-1" ABKLEMMEN BEI DER KESSELGÄBLASE/BRENNER BEDIENUNG DER ELEKTRONISCHE REGELUNG
 KONNEKTORY "PT-C" A "PT-1" ODPOJIT PŘI OVLÁDÁNÍ KOTLOVÉHO VENTILÁTORU/HOŘÁKU ELEKTRONICKOU REGULACI
- (F) WHEN ELECTRONIC REGULATION CONTROL BOILER FAN/PELLETS BURNER - CHANGE CONNECTOR "BT-N1" FOR CONNECTOR "BT-N1 REG"
 DEN AUSWECHSELN KONNEKT, "BT-N1" FÜR KONNEKT, "BT-N1 REG" BEI DER KESSELGÄBLASE/BRENNER BEDIENUNG DER ELEKTRON, REG.
 PŘEHODIT SVORKY "BT-N1" ZA "BT-N1 REG" PŘI OVLÁDÁNÍ KOTLOVÉHO VENTILÁTORU/HOŘÁKU ELEKTRONICKOU REGULACI
- (G) WHEN ELECTRONIC REGULATION CONTROL BOILER FAN/BURNER/PUMP/ - CHANGE CONNECTOR "ST-2" TO CONNECTOR "ST-2 REG"
 DEN AUSWECHSELN KONNEKTOR "ST-2" FÜR KONNEKT, "ST-2 REG" BEI DER GÄBLASE/BRENNER/PUMPE BEDIENUNG DER ELEKTRON, REGELUNG
 PŘEHODIT SVORKY "ST-2" ZA "ST-2 REG" PŘI OVLÁDÁNÍ KOTLOVÉHO VENTILÁTORU/HOŘÁKU/ČERPADLA ELEKTRONICKOU REGULACI
- (H) WHEN ELECTRONIC REGULATION CONTROL PELLETS BURNER - CHANGE CONNECTOR "L2" TO CONNECTOR "L2 REG"
 DEN AUSWECHSELN KONNEKTOR "L2" FÜR KONNEKT, "L2 REG" BEI DER BRENNER BEDIENUNG DER ELEKTRON, REGELUNG
 PŘEHODIT SVORKY "L2" ZA "L2 REG" PŘI OVLÁDÁNÍ PELETŮVÉHO HOŘÁKU ELEKTRONICKOU REGULACI
- (I) NO WITH ACCD01 - MODUL AD02 FOR VENTILATOR CONTROL FROM BURNER A25/45
 NEIN MIT ACCD01 - MODUL AD02 FÜR VENTILATORBEDIENUNG BEI DEM BRENNER A25/45
 NEPLATÍ S ACCD01 - MODUL AD02 K OVLÁDÁNÍ VENTILÁTORU KOTLE HOŘÁKEM A25/45
- (J) NO WITH ACCD01 - MODUL AD02 FOR BOILERPUMP CONTROL FROM BURNER A25/45
 NEIN MIT ACCD01 - MODUL AD02 FÜR KESSELPUMPEBEDIENUNG BEI DEM BRENNER A25/45
 NEPLATÍ S ACCD01 - MODUL AD02 K OVLÁDÁNÍ ČERPADLA KOTLE HOŘÁKEM A25/45

14-01-01_DCxxS HORAK_A25-45_6P_2AD02

21. Electric wiring diagram connection of the boilers DCxxS(X), CxxS(T), ACxxS, KCxxS, DCxxRS with exhaust fan, with 6-pin connector and two modules AD02 - to control exhaust fan of the boiler and pump in the boiler circuit from burner control unit AC07X (R and R2)

EN

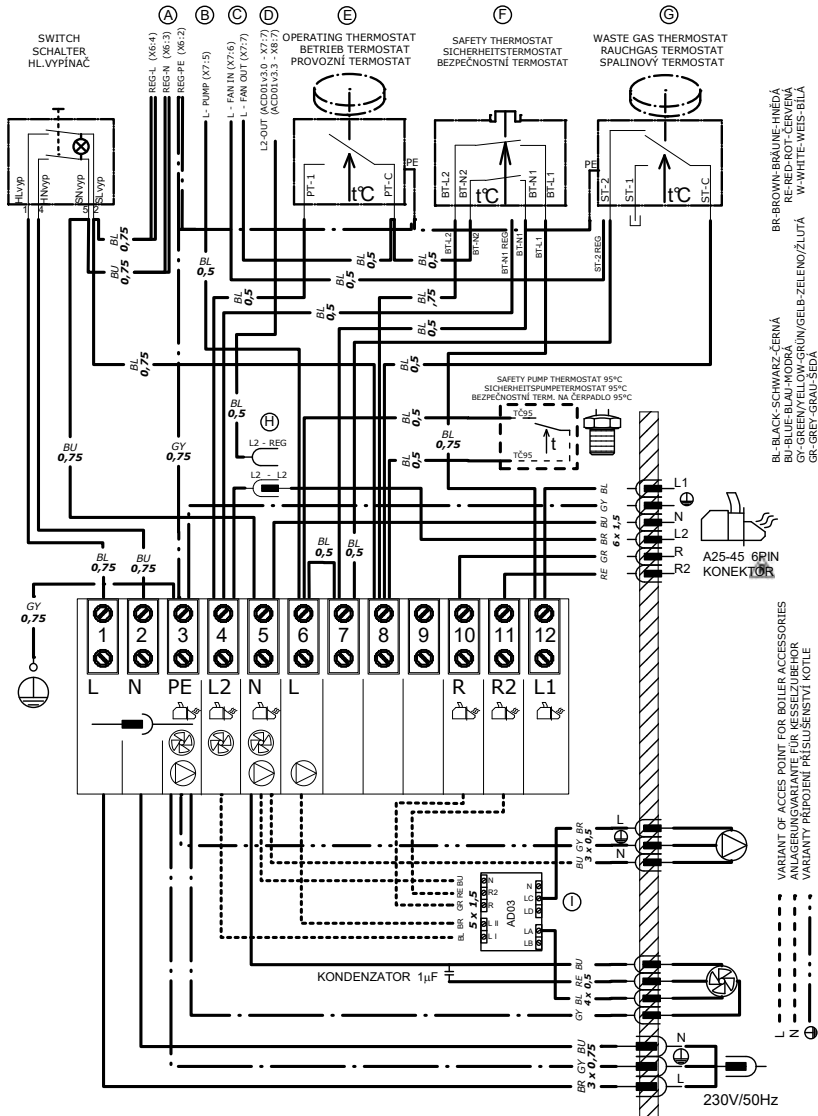

WHEN USE ELECTRONIC REGULATION ACCD1 AND PELLETBURNER A25-45 MUST BE THESE CHANGES OF WIRING:
 BEI DER STEUERUNG DES KESSELBETRIEBES DER ELEKTRONISCHE REGELUNG ACCD1 UND PELLETBRENNER A25-45 MÜSSEN DIESE ÄNDERUNGEN MACHEN SEIN:
 PŘI ZAPOJENÍ ELEKTRONICKÉ REGULACE ACCD1 A PELETOVÉHO HOŘÁKU A25-45 PŘEVEDTE TYTO ZMĚNY:

- (A) VARIANTS OF RESERVOIR POINTS "REG L,N,PE" (FERRULE/FASTON 6,3) FOR ELECTRONIC REGULATION
 SPEISEKLEMMENVARIANTEN "REG L,N,PE" (ADRENHÜLSE/FASTON 6,3) FÜR ELEKTRONISCHE REGELUNG
 VARIANTY NÁPĚČÍCH SVOREK "REG L,N,PE" (DUTINKA/FASTON 6,3) PRO ELEKTRONICKOU REGULACI
- (B) RESERVOIR POINT "L-PUMP" OF BOILERPUMP TO THE ELECTRONIC REGULATION
 SPEISEKLEMME "L-PUMP" DER KESSELPUMPE FÜR DIE ELEKTRONISCHE REGELUNG
 PŘIPOJOVACÍ SVORKA "L-PUMP" KOTLOVÉHO ČERPADLA DO ELEKTRONICKÉ REGULACE
- (C) RESERVOIR POINT "L - FAN IN" AND "L - FAN OUT" OF BOILER FAN TO THE ELECTRONIC REGULATION
 SPEISEKLEMME "L - FAN IN" UND "L - FAN OUT" DER KESSELGEBLÄSE FÜR DIE ELEKTRONISCHE REGELUNG
 PŘIPOJOVACÍ SVORKA "L - FAN IN" A "L - FAN OUT" KOTLOVÉHO VENTILÁTORU DO ELEKTRONICKÉ REGULACE
- (D) RESERVOIR POINT "L2" OF BURNER TO THE ELECTRONIC REGULATION (BY THE SOFTWARE VERSION OF ACCD1)
 SPEISEKLEMME "L2" DER BRENNER FÜR DIE ELEKTRONISCHE REGELUNG (GEMÄß SOFTWARE VERSION ACCD1)
 PŘIPOJOVACÍ SVORKA "L2" HOŘÁKU DO ELEKTRONICKÉ REGULACE (PODLE VERZE SOFTWARE ACCD1)
- (E) WHEN ELECTRONIC REGULATION CONTROL BOILER FAN/BURNER - CONNECTORS "PT-C" AND "PT-1" MUST BE UNCONNECT
 DEN KONNEKTOREN "PT-C" UND "PT-1" ABKLEMMEN BEI DER KESSELGEBLÄSE/BRENNER BEDIENUNG DER ELEKTRONISCHE REGELUNG
 KONNEKTORY "PT-C" A "PT-1" ODPOJIT PŘI OVLÁDÁNÍ KOTLOVÉHO VENTILÁTORU/HOŘÁKU ELEKTRONICKOU REGULACÍ
- (F) WHEN ELECTRONIC REGULATION CONTROL BOILER FAN/PELLETS BURNER - CHANGE CONNECTOR "BT-N1" FOR CONNECTOR "BT-N1 REG"
 DEN AUSWECHSELN KONNEKT. "BT-N1" FÜR KONNEKT. "BT-N1 REG" BEI DER KESSELGEBLÄSE/BRENNER BEDIENUNG DER ELEKTRON. REGUL.
 PŘEHODIT SVORKY "BT-N1" ZA "BT-N1 REG" PŘI OVLÁDÁNÍ KOTLOVÉHO VENTILÁTORU/HOŘÁKU ELEKTRONICKOU REGULACÍ
- (G) WHEN ELECTRONIC REGULATION CONTROL BOILER FAN/BURNER/PUMP/ - CHANGE CONNECTOR "ST-2" TO CONNECTOR "ST-2 REG"
 DEN AUSWECHSELN KONNEKTOR "ST-2" FÜR KONNEKT. "ST-2 REG" BEI DER GÄBLÄSE/BRENNER/PUMPE BEDIENUNG DER ELEKTRON. REGULUNG
 PŘEHODIT SVORKY "ST-2" ZA "ST-2 REG" PŘI OVLÁDÁNÍ KOTLOVÉHO VENTILÁTORU/HOŘÁKU/ČERPADLA ELEKTRONICKOU REGULACÍ
- (H) WHEN ELECTRONIC REGULATION CONTROL PELLETS BURNER - CHANGE CONNECTOR "L2" TO CONNECTOR "L2 REG"
 DEN AUSWECHSELN KONNEKTOR "L2" FÜR KONNEKT. "L2 REG" BEI DER BRENNER BEDIENUNG DER ELEKTRON. REGULUNG
 PŘEHODIT SVORKY "L2" ZA "L2 REG" PŘI OVLÁDÁNÍ PELETOVÉHO HOŘÁKU ELEKTRONICKOU REGULACÍ
- (I) NO WITH ACCD1 - MODUL AD03 FOR CONTROL VENTILATOR AND BOILERPUMP FROM BURNER A25/45
 NEIN MIT ACCD1 - MODUL AD03 FÜR BEDIENUNG VENTILATOR UND KESSELPUMPE BEI DEM BRENNER A25/45
 NEPLATI S ACCD1 - MODUL AD03 K OVLÁDÁNÍ VENTILÁTORU A ČERPADLA KOTLE HOŘÁKEM A25/45

VARIANT OF ACCESS POINT FOR BOILER ACCESSORIES
 ANLAGERVARIANTE FÜR KESSELZUBEHÖR
 VARIANTY PŘIPOJENÍ PŘÍSLUŠENSTVÝ KOTLE

BR-BROWN-BRAUNE-HNĚDÁ
 RE-RED-ROT-ROTER
 BL-BLACK-SCHWARZ-ČERNÁ
 BU-BLUE-BLAU-MODRÁ
 GY-GREEN-YELLOW-GRÜN-GELB
 W-WHITE-WEISS-BILÁ
 GR-GRAY-GRAU-SIEDE

13-01-01_DCxxS HORAK_6P_AD03

22. Wiring diagram connection of DCxxS(X), CxxS(T), ACxxS, KCxxS, DCxxRS boilers with exhaust fan, model with 6-pin connector and two AD03 modules - to control exhaust fan of the boiler and pump in the boiler circuit from AC07X burner control unit (R and R2) - 3/2017 modele

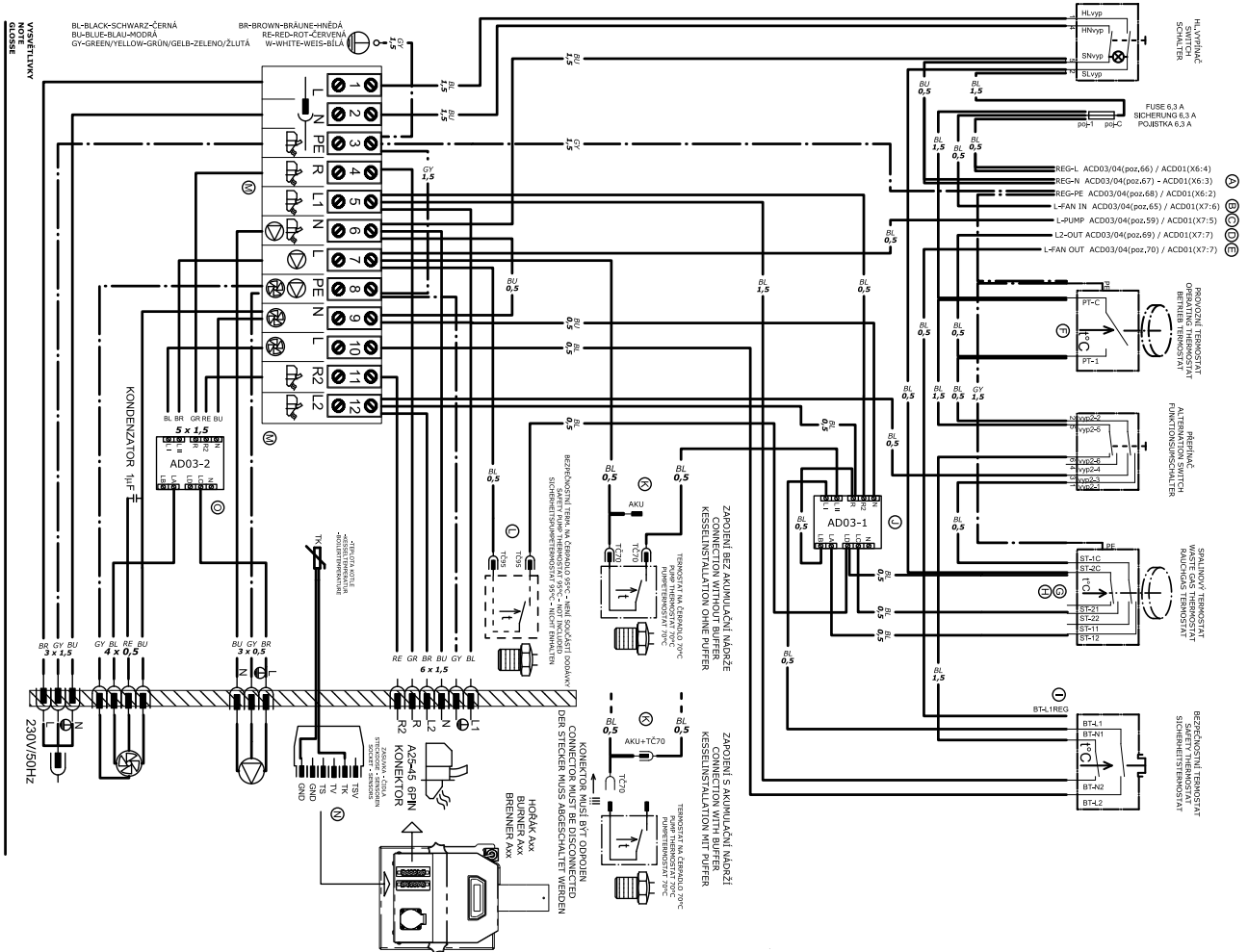

VYSVĚTLIVKY
NOTE
GLOSSE

- A** VARIANTY NAPÁJECÍCH SVOREK "REG L,N,PE" (DUTINKA/FASTON 6,3) PRO ELEKTRONICKOU REGULACI
VARIANTS OF RESERVOIR POINTS "REG L,N,PE" (FERRULE/FASTON 6,3) FOR ELECTRONIC REGULATION ANSCHLUSSKLEMMEN "REG L,N,PE" (ADERENDHÜLSE/FASTON 6,3) FÜR ELEKTRONISCHE REGELUNG
- B** PŘIPOJOVACÍ SVORKA "L-PUMP" KOTLOVÉHO ČERPADLA DO ELEKTRONICKÉ REGULACE
RESERVOIR POINT "L-PUMP" OF BOILER PUMP TO THE ELECTRONIC REGULATION ANSCHLUSSKLEMME "L-PUMP" DER KESSELpumPE FÜR DIE ELEKTRONISCHE REGELUNG
- C** PŘIPOJOVACÍ SVORKA "L-FAN-OUT" KOTLOVÉHO VENTILÁTORU DO ELEKTRONICKÉ REGULACE
RESERVOIR POINT "L-FAN-OUT" OF BOILER FAN TO THE ELECTRONIC REGULATION ANSCHLUSSKLEMME "L-FAN-OUT" DER KESSELGEBLÄSE FÜR DIE ELEKTRONISCHE REGELUNG
- D** PŘIPOJOVACÍ SVORKA "L2-OUT" HORÁKU DO ELEKTRONICKÉ REGULACE
RESERVOIR POINT "L2-OUT" OF BURNER TO THE ELECTRONIC REGULATION ANSCHLUSSKLEMME "L2-OUT" DER BRENNER FÜR DIE ELEKTRONISCHE REGELUNG
- E** PŘIPOJOVACÍ SVORKA "L-FAN-IN" KOTLOVÉHO VENTILÁTORU DO ELEKTRONICKÉ REGULACE
RESERVOIR POINT "L-FAN-IN" OF BOILER FAN TO THE ELECTRONIC REGULATION ANSCHLUSSKLEMME "L-FAN-IN" DER KESSELGEBLÄSE FÜR DIE ELEKTRONISCHE REGELUNG
- F** KONEKTORY "PT-C" A "PT-1" ODPOJIT PŘI OVLÁDÁNÍ HORÁKU A VENTILÁTORU KOTLE ELEKTRONICKOU REGULACI
WHEN ELECTRONIC REGULATION CONTROL BURNER AND FAN - CONNECTORS "PT-C" AND "PT-1" MUST BE UNCONNECTED DEN KONNEKTOREN "PT-C" UND "PT-1" ABKLEMMEN BEI DER BRENNERBEDIENUNG UND KESSELGÄSEBEDIENUNG DER ELEKTRONIC REGELUNG
- G** KONEKTORY "ST-1C" A "ST-12" ODPOJIT PŘI OVLÁDÁNÍ VENTILÁTORU KOTLE ELEKTRONICKOU REGULACI
WHEN ELECTRONIC REGULATION CONTROL BOILER PUMP - CONNECTORS "ST-1C" AND "ST-12" MUST BE UNCONNECTED DEN KONNEKTOREN "ST-1C" UND "ST-12" ABKLEMMEN BEI DER KESSELpumPEBEDIENUNG DER ELEKTRONIC REGELUNG
- H** KONEKTORY "ST-2C" A "ST-22" ODPOJIT PŘI OVLÁDÁNÍ ČERPADLA KOTLE ELEKTRONICKOU REGULACI
WHEN ELECTRONIC REGULATION CONTROL BOILER PUMP - CONNECTORS "ST-2C" AND "ST-22" MUST BE UNCONNECTED DEN KONNEKTOREN "ST-2C" UND "ST-22" ABKLEMMEN BEI DER KESSELpumPEBEDIENUNG DER ELEKTRONIC REGELUNG
- I** PŘEMOČTÍ SVORKY "BT-1" ZA "BT-L1" REG PŘI OVLÁDÁNÍ KOTLOVÉHO VENTILÁTORU ELEKTRONICKOU REGULACI
WHEN ELECTRONIC REGULATION CONTROL BOILER FAN - CHANGE CONNECTOR "BT-L1" TO CONNECTOR "BT-1" REG DEN AUSWECHSELN KONNEKTOR "BT-L1" FÜR KONNEKT. "BT-1" REG BEI DER KESSELGEBLÄSE BEDienung DER ELEKTRON. REGELUNG
- J** MODUL AD03-1 K OVLÁDÁNÍ VENTILÁTORU A ČERPADLA KOTLE BEZ SPALINOVÉHO TERMOSTATU V POZICI 0-II
MODUL AD03-1 FÜR BEDienung KESSELGEBLÄSE UND KESSELpumPE OHNE RAUCHGASTHERMOSTAT IN POSITION 0-II
- K** KONEKTORY "TČ70" A "AKU" ODPOJIT PŘI OVLÁDÁNÍ ČERPADLA KOTLE ELEKTRONICKOU REGULACI
WHEN ELECTRONIC REGULATION CONTROL BOILER PUMP - CONNECTORS "TČ70" AND "AKU" MUST BE UNCONNECTED DEN KONNEKTOREN "TČ70" UND "AKU" ABKLEMMEN BEI DER KESSELpumPEBEDIENUNG DER ELEKTRONIC REGELUNG
- L** KONEKTORY "TČ95" ODPOJIT PŘI OVLÁDÁNÍ ČERPADLA KOTLE ELEKTRONICKOU REGULACI
WHEN ELECTRONIC REGULATION CONTROL BOILER PUMP - CONNECTORS "TČ95" MUST BE UNCONNECTED DEN KONNEKTOREN "TČ95" ABKLEMMEN BEI DER KESSELpumPEBEDIENUNG DER ELEKTRONIC REGELUNG
- M** VODIČE "R,R2" ODPOJIT Z poz.4,11 PŘI OVLÁDÁNÍ VENTILÁTORU A ČERPADLA KOTLE ELEKTRONICKOU REGULACI
WHEN ELECTRONIC REGULATION CONTROL BOILER FAN AND PUMP - CABLES "R,R2" MUST BE UNCONNECTED FROM pos.4,11
- N** KABELN "R,R2" AUS POS.4,11 TRENNEN BEI DER KESSELGEBLÄSE UND PUMPEBEDienung DER ELEKTRONIC REGELUNG
- O** ČIDLO "TK" PRO HORÁK A25
KESSEL WASSER FÜHLER "TK" FÜR BRENNER A25
- P** MODUL AD03-2 K OVLÁDÁNÍ VENTILÁTORU A ČERPADLA KOTLE HORÁKEM A25
MODUL AD03-2 FÜR CONTROL BOILERFAN AND BOILERPUMP FROM BURNER A25
- Q** MODUL AD03-2 FÜR BEDienung KESSELGEBLÄSE UND KESSELpumPE BEI DEM BRENNER A25

20-10-20_DcxxS_HORAK_2AD03_PUMP.sch

23. Commissioning



CAUTION - The system may only be put in operation if the burner is connected to the boiler, the boiler to a chimney with sufficient draught via a flue gas duct and in the fuel bin there is a sufficient quantity of pellets of the corresponding quality. **Pellets made of soft wood without bark, i.e. white pellets with the diameter of 6 to 8 mm and length of 5 to 25 mm are considered as high-quality pellets. These pellets do not cake. Burning of dark pellets or pellets with bark that contain visible dark dots produces cake that must be removed from the burner mouth once a day. Otherwise the combustion chamber and the feeding hose from the conveyor will get clogged.**



INFO - The pellets have to be stored in dry and clean containers (areas). When filling the fuel bin, the pellets **must not be contaminated by foreign objects** that could cause a **blockage of the conveyor** or have an impact on the burning process.

Requirements for the external conveyor and pellet bin at the first start of the burner:

- The worm conveyor must be positioned in the bin in such a way to be able to easily pick up pellets. In the case of a fuel bin whose pellet level will be higher than 2 metres a roof will have to be installed over the conveyor to prevent blocking of the conveyor. Blocking of the conveyor is caused by dust in the pellets in combination with high pressure caused by the height of the pellet level. **ATMOS 250, 500 and 1000 l pellet bins do not require the installation of the roof.**
- The hose between the burner and conveyor must be tensioned, properly fixed and must have such an inclination to enable trouble-free falling of pellets to the burner.
- The connector of the work conveyor must be plugged into the socket on the burner.

Procedure of drawing pellets to the conveyor

- Plug the connector of the external worm conveyor to a standard wall socket. As soon as the first pellets get over the top point and start to fall to the burner via the elastic hose, plug the connector of the external worm conveyor back into the socket on the burner.

Normal operation:

- On the control thermostat on the boiler panel set the required operation temperature of 80 - 90 °C and turn on the switch of the burner located on the boiler panel and the main switch. For boilers with a built-in burner in the upper doors reduce the combustion thermoregulator for heating.

The STARTup mechanism consists of the following steps:

- At the start the **worm conveyor and the ignition spiral are started** (the fan on the burner is stopped).
- The worm conveyor will run for the time set by **parameter T1**, necessary for the delivery of the amount for pellets for optimum ignition. After the delivery of the ignition amount of fuel the worm conveyor will stop. **The burner fan will be started** at the ignition speed - **parameter S2** as well as the exhaust fan (if the boiler is equipped with one and is set accordingly – reserve **R** and parameter **S6**).

- After the ignition of pellets **the photocell will sense light**, which will cause the **ignition spiral to switch off** with a slight delay.
- The burner will pass over to the **stage of perfect burning of fuel - set by parameter T7**.

The OPERATION algorithm consists of the following steps:

- When the fuel burns perfectly, the burner will get to the **stage of gradual increase of the power to the nominal value - parameter T10**.
- After achieving the nominal power the burner works in the normal mode until the heating system or the accumulation tank is heated to the required temperature. **The power of the burner results from the hourly quantity of pellets** delivered by the worm conveyor to the combustion chamber. The worm conveyor **works in the intermittent mode set by parameters T4 and T6**. Parameters T4 and T6 are set in accordance with the instructions on pages 34 - 36.
- After setting the nominal power of the burner you must also set the **amount of combustion air** necessary for complete burning of fuel. This setting is performed **with the air flap on the burner fan**. **The exact setting should be carried out by a trained person with the use of a flue gas analyzer**.

The burning out algorithm is designed as follows:

- After the **achievement of the set temperature** at the boiler thermostat (e.g. 85 °C) or temperature in the accumulation tank - temperature at the bottom sensor (TS), the electronic control unit of the burner will switch off the external **worm conveyor**. Thanks to this, the **pellets** in the combustion chamber will **burn out**. Optimal burning out of pellets in the combustion chamber is additionally supported by the operation of the burner fan for a certain time - **parameter T5**. After subsequent drop of the temperature of water in the boiler or discharge of the accumulation tank - temperature at the top sensor (TV), the burner will be re-started in the same way as described in the text above. If the accumulation tank is connected to a solar exchanger and activating functions for automatic optimization (switching) of sensors, parameter S15 = 3, the burner may be turned off by sensor TK instead of sensor TS.

The other algorithms are designed in the following way:

- If the first attempt for ignition with fuel supply fails, the burner will repeat the whole algorithm. After the second unsuccessful attempt for ignition with fuel supply the burner will proceed to the third attempt during which the fuel is not supplied any longer, but only the ignition spiral is active. After this unsuccessful attempt the burner will be put out of operation as the system has probably run out of pellets or a fault has occurred.
- In case of a short-term interruption of power supply to the burner, **the burner will automatically renew its operation** after performing diagnostic checks, complete burning out of pellets and a new start.



INFO - This sequence has been set intentionally to ensure safe and trouble-free operation of the burner.

24. Control and setting of the burner

Display and control panel

The electronic control unit of the burner is equipped with four keys for easy and intuitive control.

Enter - key for **confirming** a command and parameter or for **entering a menu**

Esc - key for **return** from a menu

↑ **Up arrow** - key for **browsing** in the menus or for **increasing** the value of a parameter

↓ **Down arrow** - key for **browsing** in the menus or for **decreasing** the value of a parameter



INFO - To open the **Main Menu**, press the **Enter** key.

The **PARAMETER** submenu will appear on the display. To change the basic **permitted parameters** of the burner, confirm again - press the **Enter** key.

To switch off **OFF (STOP)** or to switch on **ON (START)** the burner or to get to the **INFORMATION, PASSWORD** or **TESTING** submenus, do not confirm the (**PARAMETER**) submenu, but continue with the up or down arrow. Always confirm the **ON (START)** and **OFF (STOP)** command or entering the particular submenu by pressing the **Enter** key. In the same way you can browse and open **individual menus** and particular **parameters** in the menu. You can **enter specific values or numbers** with the **up (+) or down (-) arrow**. Confirm the desired value with the **Enter** key. To return one step backwards or completely to the main screen press the **Esc** key once or repeatedly.

Display with keys:

1. Information about the burner status
START – start-up stage
RUN – normal operation
STOP – burning-down stage or stand-by mode
2. Temperature **TV** (see page 59) – only if TS and TV sensor are connected
3. Temperature **TS** (see page 59) – only if TS and TV sensor are connected
4. Symbol line – information about the operation of particular devices of the burner (see page 66)

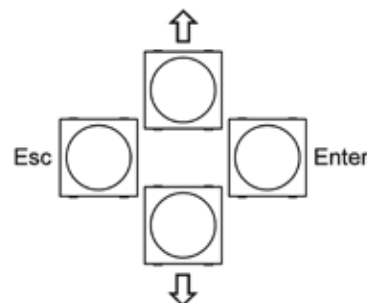
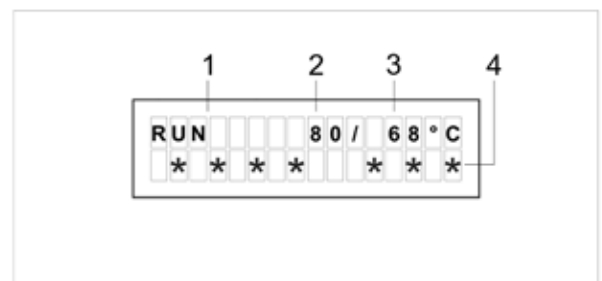

MAIN menu

PARAMETERS – this is a **separate menu** where individual parameters and functions can be set depending on the type of the boiler and heating system and the authorization level.

INFORMATION – this is a **separate menu** where you can view the current status of individual devices and elements on the A45 burner.

PASSWORD – this is a very important parameter, **designed only for service engineers**. After entering the required password the service engineer is allowed to change some parameters depending on the authorization level.

Basic authorization levels: User, service engineer (installer), manufacturer

Accessible parameters depending on authorization:

Customer: T1, T4, T6, S16, S17, S18, S19, Restart, Language

Service engineer: T1,T2, T4, T5, T6, T7, T8, T10, S1, S2, S3, S6, S11, S12, S13, S14, S15, S16, S17, S18, S19, S24, S26, S27, S28, S29, S30, S31, S32, S33, S34, S35, S36, S37, S38, S39, S40, S41, S42, S43, S44, S45, S48, S49, S50, S51, S52, S53, S54, S55, S56, S57, S58, S59, S60, S61, S62, S63, S64, S65, S66, S67, S68, OffsetTS, OffsetTV, OffsetTK, OffsetTSV, Reset, Restart, Language

Manufacturer: all



CAUTION - The customer is expressly prohibited to change parameters or functions of the burner without consent of the manufacturer or service engineer although some of them are not directly protected with a password. Otherwise the manufacturer reserves the right to decline the guarantee due to an inexpert intervention into the burner.

Particular passwords are production secret of the ATMOS Company and the service engineer (installer) is not authorized to provide them to anybody without the manufacturer's consent.



INFO - After replacement of any ignition spiral the **service engineer must enter the password: 1234, which will reset the check algorithms** for the ignition spirals. Without entering of this password the ignition spirals will never be started (activated).

Passwords and their functions

Password	Authorization / function
	Service engineer
	Manufacturer
8118	Switching off and on the fan speed control
	Locking and unlocking all parameters
1234	Reset of check algorithms for the ignition spirals

TESTING – this is a **separate menu** in which you can individually test individual elements of the burner in case of unclear issues or faults.



CAUTION – During testing the burner is out of operation and therefore before the start of testing let the burner properly burn out.

ON (START) / OFF (STOP) - switch on / switch off the burner

ON (START) – This is the command to switch on the burner. Confirm the switch-on command by pressing the **Enter** key.

OFF (STOP) – This is the command to switch off the burner. Confirm the switch-off command by pressing the **Enter** key.

PARAMETERS menu

- **Parameter T1** – Time for feeding the ignition amount of pellets... **(60 s)**
- **Parameter T2** – Maximum time for ignition of pellets (then a new attempt for ignition follows)... **(12 min)**
- **Parameter T4** – Running time of the worm conveyor after a standstill interval – power control...**(3,4 s)**
- **Parameter T5** – Rundown time of the fan after the STOP command - for optimal burning out of pellets in the combustion chamber... **(15 min)**
- **Parameter T6** – Standstill time of the worm conveyor after a running interval - power control...**(16 s)**
- **Parameter T7** – Time to achieve complete burning of the ignition amount of fuel... **(40 s)**
- **Parameter T8** – Time of fixed start of the ignition spiral in case of insufficiently burned out pellets in the combustion chamber after expiration of parameter T5 - only valid for the first ignition attempt... **(6 min)**
- **Parameter T10** – Time for gradual increase of the power of the burner to the nominal value...**(20 min)**
if **T10 = 0**, the function is off.

Setting the required power and combustion quality:

The required power is set with the use of parameters T4 and T6.

However, the actual power is also influenced by the diameter of pellets and angle of the conveyor. Therefore, you should keep in mind that if after setting the burner you change the angle of the conveyor or diameter of pellets, you will have to readjust the burner.

Adjust the combustion quality with the air flap of the fan in such a way that the **flame tips should always end 1 to 3 cm before the opposite wall. For boilers with burner built in the upper door and the combustion length of 60 cm or greater, adjust the burner in such a way that the tip of flame ends 10 to 15 cm before the opposite wall.**

You should also know that the setting of the burner is different if the boiler is equipped with an exhaust fan and if the boiler does not have an exhaust fan. **The combustion should be precisely tuned after 30 to 60 minutes of permanent operation, best with the use of a flue gas analyst. We recommend you to adjust the burner in such a way that the surplus of O₂ in the flue gas can be in the range of 8 to 10 (12) % and the average CO content can be lower than 500 (250) mg/m³. During operation the flue gas temperature must never drop below 130 °C (110 °C) and rise over 250 °C (parameter S18).**



INFO - Even though the burner is equipped with many functions (parameters) it is basically just the setting of the basic ones which characterize the **output of the burner - T4 and T6, setting of air flap and fan's speed - parameter S3.**

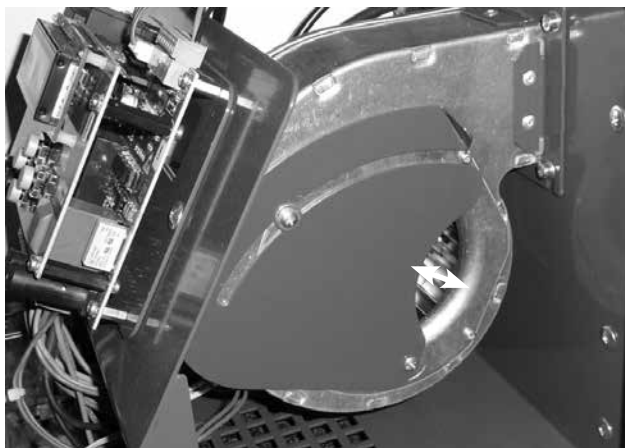

Fan of the burner with an air flap.

Settings of the air flap on the burner fan:

- by opening the air flap you will reduce the length of the flame
- by closing the air flap you will increase the length of the flame

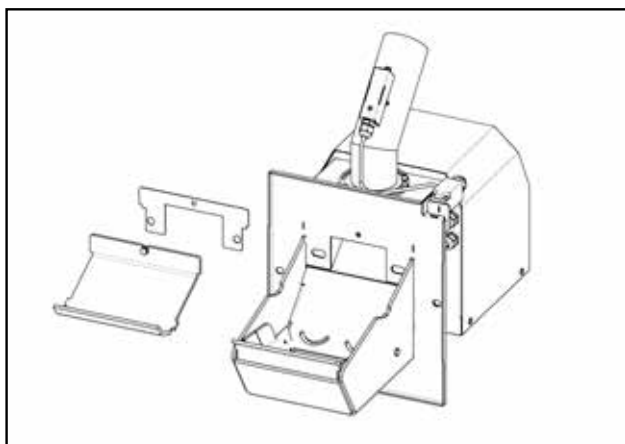

In the case of output settings below 25 kW for the ATMOS A45 burner, build a secondary air screen into the burner, it is part of the burner delivery as an accessory.

Recommended approximate setting of the burner with the use of DRA50 – 1.7, 2.5, 4 and 5 m conveyors, for individual output values and pellets with the diameter of 6 mm and conveyor angle of 45°:

Boiler output	Parameter T1	Parameter T4	Parameter T6	Parameter S3	Opening of the air flap on the burner fan of a boiler with an exhaust fan
30 – 35 kW	60 s	3,4 s	16 s	45 %	50 mm
40 – 45 kW	60 s	4,5 s	14 s	70 %	40 mm

Recommended approximate setting of the burner with use of DRA25 1,3 m and DRA25 1,7 m conveyors, for individual output values and pellets with the diameter of 6 mm and conveyor angle of 65° (compact pellet tanks AZPD and AZPU):

Boiler output	Parameter T1	Parameter T4	Parameter T6	Parameter S3	Opening of the air flap on the burner fan of a boiler with an exhaust fan
30 – 35 kW	85 s	5 s	8 s	45 %	50 mm
40 – 45 kW	85 s	10 s	9 s	70 %	40 mm



INFO – Minimum length of the pipe between the burner and the conveyor must be more than 20 cm. Maximum length of the pipe should not exceed 1 m.

• **Parameter S1** – Allowed number of attempts for ignition with fuel supply... (2).

If parameter S1 is set to 4, the fuel will always be ignited with both the ignition elements at the same time (Z1 + Z2) in 2 attempts for ignition with fuel supply.



CAUTION - Always after the last attempt for ignition with fuel supply given by parameter S1, an attempt for ignition without fuel supply will follow to test the equipment. If the fuel is not ignited after this attempt, the system will be put out of operation and the **ALARM START** error message will appear.

• **Parameter S2** - fan speed at the START... (1 %) - do not change



CAUTION - 1 % = 700 rpm. If S2 = 0, the fan is off at the start.

• **Parameter S3** – Fan speed during normal RUN... (70 %)

In normal circumstances we do not recommend you to change prescribe fan speed as it influences cooling and cleaning of inner parts of the burner. Only use the air flap to set the air quantity.

• **Parameter S4** – Fuel ignition control method... (1)

If:

a) S4 = 1... Photocell sensing

• **Parameter S6** – characterizes the first reserve R - additional output - function... (1)

The first reserve R is used mainly for controlling boiler exhaust fan (S6 = 4)



CAUTION – In the standard setting when **parameter S1 is set to 2**, you can connect to the reserve terminal R and R2 an appliance with the **maximum current of 2.46 A (approx. 566 VA)**.

In the setting when **parameter S1 is set to 4**, which means that at the start both the ignition spirals are activated simultaneously, you can connect to the reserve terminal R and R2 an appliance with the **maximum current of 0.29 A (approx. 67 VA)**.

If:

a) S6 = 1... If any fault occurs in the burner and the burner is shut down, **the reserve relay will be closed and the reserve output will be energized**. Thanks to this you can start a spare source of energy for heating of the building as e.g. a gas, electric or oil boiler.

b) S6 = 2... If any fault occurs in the burner and the burner is shut down, **the reserve relay will be opened and the reserve output will not be energized**. Thanks to this a signal can be sent to an electrically backed up device (GSM, Wifi,...) that will send information that there is a system fault or the system is not energized. **This is the opposite logic (to S6=1), which means that during normal operation the reserve is energized.**

c) S6 = 3... The reserve **function as the output function for the burner fan**, when the reserve **output is closed, is energized always when the burner fan is running** (fan mode only 100 % or OFF). This function is applied if you want the boiler fan or exhaust fan in the chimney to run together with the burner fan during burning out (the STOP mode). This function is designed for direct supply of an external fan directly from the burner (e.g. DxxPX, PXxx).

d) S6 = 4... The reserve function as the **reversed function of the output for the burner fan**, when the reserve **output is off, is not energized always when the burner fan is running**. This function is always activated if **you connect the A45 burner with the AS25 set containing the AD02 or AD03 module, which in this case controls the exhaust fan of the boiler. Install the AD02 or AD03 module under the instrument hood of the boiler and connect it electrically between the boiler terminal board and the exhaust fan, see the wiring diagram.**

This setting and connection with AD02 or AD03 module and special connector (jumper to main switch) is **standardly used for DCxxSP(X), CxxSP, ACxxSP boilers with the function for au-**

automatic start after wood is burnt out activated (AUTOSTART – S34 = 1 or S34 = 2). Boiler exhaust fan is running simultaneously with the pellet burner during the AUTOSTART function.

e) **S6 = 5...** Reserve function as the output function for the Z1 ignition spiral when the reserve copies the run of the ignition spiral.

f) **S6 = 6...** Cleaning function of the combustion chamber or grill (flap). If the burner is in the normal START, RUN and STOP mode, the output is not energized. The output is only energized for the limited time T11, which continues immediately **after the expiration of time T5 in the STOP mode. It is not used with the A45 burner.**

g) **S6 = 7...** Reserve function as **the output function for the external worm conveyor**, when the reserve copies the run of the external worm conveyor (cycles between time T4 and T6). **The reserve output work independently** of the condition of the actual output for the external worm conveyor. This means that if the standard output for the external conveyor gets damaged, the reserve will work independently in accordance with the same program, and therefore it can be used as a replacement for the damaged output.

h) **S6 = 8...** Reserve function as **the output function for the external worm conveyor**, when the reserve copies the run of the external worm conveyor (cycles between time T4 and T6). **The reserve works in dependence on** the status of the actual output for the external worm conveyor. This means that if the output for the external conveyor gets damaged, the reserve will be switched off automatically. This function is suitable in situations when you need to control another external conveyor that supplies (feeds) pellets from a larger distance to the main conveyor from which the pellets fall directly to the burner.

i) **S6 = 9...** Reserve function as **the output function for the external worm conveyor**, when the reserve copies the run of the external worm conveyor, but with the difference that it **does not cycle, but runs permanently both during the drawing of the ignition amount and during both the times T4 and T6**. Thus, the other external conveyor runs continuously and **works independently** of the status of the actual output for the external worm conveyor. This means that if the output to the main external conveyor from which pellets directly fall to the burner gets damaged, **the reserve will keep working independently**. This function can be used in cases when you need to control another external conveyor that supplies (feeds) pellets **from a larger distance to a pellet bin at the boiler** from which the main external conveyor draws pellets to supply them directly to the burner. **Caution** - the other external conveyor must always be controlled with an additional level sensor (level meter) that will maintain the level of pellets in the pellet bin at the boiler.

j) **S6 = 10...** Reserve function as the output **function for the external worm conveyor**, when the reserve copies the run of the external worm conveyor, but with the difference that it **does not cycle, but runs permanently both during the drawing of the ignition amount and during both the times T4 and T6**. Thus, the other external conveyor runs continuously, but it **works in dependence on** the status of the actual output for the external worm conveyor. This means that if the output for the external conveyor from which pellets fall directly to the burner gets damaged, the reserve will be switched off automatically. This function is convenient in cases when you need to control another external conveyor that supplies (feeds) pellets **from a larger distance to a pellet**

bin at the boiler from which the main external conveyor draws pellets to supply them directly to the burner. **Caution** - the other external conveyor must always be controlled with an additional level sensor (level meter) that will maintain the level of pellets in the pellet bin at the boiler. This is a similar function to S6 = 9, but with a higher degree of safety.

k) S6 = 11... Reserve function for controlling boiler exhaust fan for DCxxSP(X), CxxSP, ACxxSP boiler types when the function for automatic start after wood is burnt out is activated. This function ensures that boiler exhaust fan is running only during wood burning after the wood is burnt out. When the burner is run on pellets, the boiler exhaust fan remains switched off. This function is used if you do not need or want to use the boiler exhaust fan while the burner is running. **Install the AD02 module under the instrument hood of the boiler and connect it electrically between the boiler terminal board and the exhaust fan, see the wiring diagram. It is not used with the A45 burner.**



WARNING – this is not a standard setting for DCxxSP(X), CxxSP, ACxxSP boilers with the function of automatic start (AUTOSTART – S34 = 1 or S34 = 2) after wood is burnt out (standard setting is S6 = 4).

l) S6 = 12... Reserve function for direct control of pump in the boiler circuit from the burner regulation (boiler terminal board). This function controls the pump in the boiler circuit without using AD02 or AD03 modules. This is applicable only for boilers that do not allow heating with wood (not even in emergency situations). E.g. D31P, P31. Pump output must be switched to reserve R on the boiler terminal board and the TK sensor must be installed before this function can be activated. After activation, S37, S38, S39, S40 temperature parameters must be checked and configured.

m) S6 = 13... Reserve function is the reverse output function for controlling the pump in the boiler circuit from the burner regulation (output cable from boiler with a connector – white inside) via AD02 or AD03 modules. This function controls the pump in the boiler circuit using AD02 or AD03 modules ranged into a set with pump thermostat installed into the boiler panel. **This method of pump controlling can be used for any ATMOS pellet boiler, and is therefore recommended.** AD02 or AD03 modules must be inserted and connected under the boiler hood and the TK sensor must be installed before this function can be activated. After activation, S37, S38, S39, S40 temperature parameters must be checked and configured.

n) S6 = 14... Reserve function for direct control of solar heating pump from the burner regulation (boiler terminal board). This function control solar pump when automatic sensor switching function is activated (S15=3), where the boiler is connected with accumulation tank equipped with solar exchanger and collectors. The system requires TV, TK, TS and solar sensors to be connected to the TSV solar panel. This function never uses AD02 or AD03 modules.

After activation, S26, S27, S28, S29, S30, S31, S32, S33 temperature parameters must be checked and configured.

This function is specially designed for boilers: D30P, D31P, D40P, D50P (D45P), P30, P31, P40, P50



CAUTION - the direct controlling function of solar heating from pellet burner cannot be used for DCxxSP(X), CxxSP, ACxxSP boilers and boilers with burner built into the upper doors. This function also cannot be used when the pump is simultaneously controlled in the boiler circuit from the burner regulation (TK sensor cannot be simultaneously in boiler and accumulation tank).

o) S6 = 15..... Reserve function for the compressor control during the function for automatic burner cleaning using compressed air. Power element designed for switching and powering the compressor (e.g. contactor) must be connected between reserve output R and the compressor. This function is connected with S6 (14), S41, S42, S43, S44, S45, S46, S47 parameter, which must be checked and configured.

p) S6 = 16..... Reserve function for controlling el.fan during the function for automatic burner cleaning using compressed air. This function is connected with S6 (14), S41, S42, S43, S44, S45, S46, S47 parameter, which must be checked and configured.

Special function for turning on reserve output R according to the temperature of a concrete sensor:

a) e.g. function: TS>..... means that if the TS sensor temperature is higher then the set value in S48 parameter – Temperature A, reserve output R will be activated

b) e.g. function: TS<..... means that if the TS sensor temperature is higher then the set value in S48 parameter – Temperature A, reserve output R will be deactivated

c) e.g. function: TS,TV>..... means that if the TS and TV sensor temperature is higher at the same time then the set value in S48 parameter – Temperature A and S50 – Temperature B, reserve output R will be activated (Temperature A = first position (TS), Temperature B = second position (Tv)).

d) e.g. function TS,TK<..... means that if the TS and TK sensor temperature is higher at the same time then the set value in S48 parameter – Temperature A and S50 – Temperature B, reserve output R will be deactivated (Temperature A = first position (TS), Temperature B = second position (Tk)).

Individual functions:

- | | | |
|-----------|--------------|--------------|
| (17) TS> | (24) TSV< | (31) TV,TK> |
| (18) TS< | (25) TS,TV> | (32) TV,TK< |
| (19) TV> | (26) TS,TV< | (33) TV,TSV> |
| (20) TV< | (27) TS,TK> | (34) TV,TSV< |
| (21) TK> | (28) TS,TK< | (35) TK,TSV> |
| (22) TK< | (29) TS,TSV> | (36) TK,TSV< |
| (23) TSV> | (30) TS,TSV< | |

• Parameter S7 – Function of the main external pellet conveyor – **do not change in any case... (1)**
if:

a) S7 = 1... Standard function when in the START mode the external conveyor supplies the ignition amount of fuel during **time T1, when it runs continuously.**
In the RUN mode the external conveyor doses fuel by **alternating times T4 (run) and T6 (standstill).**

• **Parameter S10** – Specifies the behaviour of the burner in case of a power supply failure or when the boiler is activated with the main switch – **do not change in any case... (1)**

a) **S10 = 1**... Function when after a power supply failure the electronic control unit tests the status of the burner, evaluating with the use of the photocell or by means of the flue gas temperature that the burner (boiler) is still burning. Subsequently, it first passes into the **burning out mode T5 after which it proceeds to the new START immediately.**

b) **S10 = 2**... Function when after a power supply failure the electronic control unit tests the status of the burner, evaluating with the use of the photocell or by means of the flue gas temperature that the burner (boiler) is still burning passes over directly to the normal **RUN** mode in accordance with a certain algorithm.



CAUTION - Never use for the A45 burner - function for other types of devices (danger of return burning)

• **Parameter S11** – Photocell sensitivity – threshold for fuel ignition..... **(50 %) - do not change**

• **Parameter S12** – Photocell sensitivity for flame sensing - threshold for embers... **(1 %) - do not change**

• **Parameter S13** – Fixed running time of the ignition spiral..... **(0 min) - do not change**

Function of the ignition spiral when at every start the ignition spiral runs for a fixed time defined by a direct value, independently on flame evaluation by the photocell or flue gas sensor. It is designed for special applications and in the case of its activation the function of automatic flame sensing from embers, characterized by parameter S12, is automatically switched off.

• **Parameter S14** – characterizes the second **reserve R2** - additional output - function... **(0)**

The second reserve R2 is used mainly for controlling the pump in boiler circuit (S14 = 13)



CAUTION – In the standard setting when **parameter S1 is set to 2**, you can connect to the reserve R and R2 reserve terminal an appliance with the **maximum current of 2.46 A (approx. 566 VA).**

In the setting when **parameter S1 is set to 4**, which means that at the start both the ignition spirals are activated simultaneously, you can connect to the reserve R and R2 terminal an appliance with the **maximum current of 0.29 A (approx. 67 VA).**

if:

a) **S14 = 1**... If any fault occurs in the burner and the burner is shut down, **the reserve relay will be closed and the reserve output will be energized.** Thanks to this you can start a spare source of energy for heating of the building as e.g. a gas, electric or oil boiler.

b) S14 = 2... If any fault occurs in the burner and the burner is shut down, **the reserve relay will be opened and the reserve output will not be energized.** Thanks to this a signal can be sent to an electrically backed up device (GSM, Wifi,...) that will send information that there is a system fault or the system is not energized. **This is the opposite logic (to S14 = 1), which means that during normal operation the reserve is energized.**

c) S14 = 3... The reserve function as the output function for the burner fan, when the reserve output is closed, is energized always when the burner fan is running (fan mode only 100 % or OFF). This function is applied if you want the boiler fan or exhaust fan in the chimney to run together with the burner fan during burning out (the STOP mode). This function is designed for direct supply of an external fan directly from the burner (např. DxxPX, Pxxx).

d) S14 = 4... The reserve function as the reversed function of the output for the burner fan, when the reserve output is off, is not energized always when the burner fan is running. This function is always activated if you connect the A45 burner with the AS25 set containing the AD02 or AD03 module, which in this case controls the exhaust fan of the boiler. **Install the AD02 or AD03 module under the instrument hood of the boiler and connect it electrically between the boiler terminal board and the exhaust fan, see the wiring diagram.**

This setting and connection with AD02 or AD03 module and special connector (jumper to main switch) is standardly used for DCxxSP(X), CxxSP, ACxxSP boilers with the function for automatic start after wood is burnt out activated (AUTOSTART – S34 = 1 or S34 = 2). **Boiler exhaust fan is running simultaneously with the pellet burner during the AUTOSTART function.**

e) S14 = 5... Reserve function as the output function for the Z1 ignition spiral when the reserve copies the run of the ignition spiral.

f) S14 = 6... Cleaning function of the combustion chamber or grill (flap). If the burner is in the normal START, RUN and STOP mode, the output is not energized. The output is only energized for the limited time T11, which continues immediately after the expiration of time T5 in the STOP mode. **It is not used with the A45 burner.**

g) S14 = 7... Reserve function as the output function for the external worm conveyor, when the reserve copies the run of the external worm conveyor (cycles between time T4 and T6). **The reserve output work independently** of the condition of the actual output for the external worm conveyor. This means that if the standard output for the external conveyor gets damaged, the reserve will work independently in accordance with the same program, and therefore it can be used as a replacement for the damaged output.

h) S14 = 8... Reserve function as the output function for the external worm conveyor, when the reserve copies the run of the external worm conveyor (cycles between time T4 and T6). **The reserve works in dependence on** the status of the actual output for the external worm conveyor. This means that if the output for the external conveyor gets damaged, the reserve will be switched off automatically. This function is suitable in situations when you need to control another external conveyor that supplies (feeds) pellets from a larger distance to the main conveyor from which the pellets fall directly to the burner.

i) S14 = 9... Reserve function as the output function for the external worm conveyor, when

the reserve copies the run of the external worm conveyor, but with the difference that it **does not cycle, but runs permanently both during the drawing of the ignition amount and during both the times T4 and T6**. Thus, the other external conveyor runs continuously and **works independently** of the status of the actual output for the external worm conveyor. This means that if the output to the main external conveyor from which pellets directly fall to the burner gets damaged, **the reserve will keep working independently**. This function can be used in cases when you need to control another external conveyor that supplies (feeds) pellets **from a larger distance to a pellet bin at the boiler** from which the main external conveyor draws pellets to supply them directly to the burner. **Caution** - the other external conveyor must always be controlled with an additional level sensor (level meter) that will maintain the level of pellets in the pellet bin at the boiler.

j) S14 = 10... Reserve function as the output **function for the external worm conveyor**, when the reserve copies the run of the external worm conveyor, but with the difference that it **does not cycle, but runs permanently both during the drawing of the ignition amount and during both the times T4 and T6**. Thus, the other external conveyor runs continuously, but it **works in dependence on** the status of the actual output for the external worm conveyor. This means that if the output for the external conveyor from which pellets fall directly to the burner gets damaged, the reserve will be switched off automatically. This function is convenient in cases when you need to control another external conveyor that supplies (feeds) pellets **from a larger distance to a pellet bin at the boiler** from which the main external conveyor draws pellets to supply them directly to the burner. **Caution** - the other external conveyor must always be controlled with an additional level sensor (level meter) that will maintain the level of pellets in the pellet bin at the boiler. This is a similar function to S6 = 9, but with a higher degree of safety.

k) S14 = 11... Reserve function for controlling boiler exhaust fan for DCxxSP boiler types when the function for automatic start after wood is burnt out is activated. This function ensures that boiler exhaust fan is running only during wood burning after the wood is burnt out. When the burner is run on pellets, the boiler exhaust fan remains switched off. This function is used if you do not need or want to use the boiler exhaust fan while the burner is running. **Install the AD02 module under the instrument hood of the boiler and connect it electrically between the boiler terminal board and the exhaust fan, see the wiring diagram. It is not used with the A45 burner.**



WARNING – this is not a standard setting for DCxxSP(X), CxxSP, ACxxSP boilers with the function of automatic start

(AUTOSTART – S34 = 1 or S34 = 2) after wood is burnt out (standard setting is S14 = 13).

l) S14 = 12... Reserve function for direct control of pump in the boiler circuit from the burner regulation (boiler terminal board). This function controls the pump in the boiler circuit without using AD02 or AD03 modules. This is applicable only for boilers that do not allow heating with wood (not even in emergency situations). E.g. D31P, P31. Pump output must be switched to reserve R2 on the boiler terminal board and the TK sensor must be installed before this function can be activated. After activation, S37, S38, S39, S40 temperature parameters must be checked and configured.

m) S14 = 13... Reserve function is the **reverse output function** for controlling the pump in the boiler circuit from the burner regulation (output cable from boiler with a connector – white inside) via AD02 or AD03 modules. This function controls the pump in the boiler circuit using AD02 or AD03 modules ranged into a set with pump thermostat installed into the boiler panel.

This method of pump controlling can be used for any ATMOS pellet boiler, and is therefore recommended. AD02 or AD03 modules must be inserted and connected under the boiler hood and the TK sensor must be installed before this function can be activated. After activation, S37, S38, S39, S40 temperature parameters must be checked and configured.

n) S14 = 14... Reserve function for direct control of solar heating pump from the burner regulation (boiler terminal board). This function control solar pump when automatic sensor switching function is activated (S15=3), where the boiler is connected with accumulation tank equipped with solar exchanger and collectors. The system requires TV, TK, TS and solar sensors to be connected to the TSV solar panel. This function never uses AD02 or AD03 modules.

After activation, S26, S27, S28, S29, S30, S31, S32, S33 temperature parameters must be checked and configured.

This function is specially designed for boilers: D30P, D31P, D40P, D50P (D45P), P30, P31, P40, P50



CAUTION - the direct controlling function of solar heating from pellet burner cannot be used for DCxxSP(X), CxxSP, ACxxSP boilers and boilers with burner built into the upper doors. This function also cannot be used when the pump is simultaneously controlled in the boiler circuit from the burner regulation (TK sensor cannot be simultaneously in boiler and accumulation tank).

o) S14 = 15... Reserve function for the compressor control during the function for automatic burner cleaning using compressed air. Power element designed for switching and powering the compressor (e.g. contactor) must be connected between reserve output R and the compressor.

This function is connected with S6 (14), S41, S42, S43, S44, S45, S46, S47 parameter, which must be checked and configured.

p) S14 = 16... Reserve function for controlling el.fan during the function for automatic burner cleaning using compressed air. This function is connected with S6(14), S41, S42, S43, S44, S45, S46, S47 parameter, which must be checked and configured.

Special function for turning on reserve output R2 according to the temperature of a concrete sensor:

a) e.g. function: TS>... means that if the TS sensor temperature is higher then the set value in S52 parameter – Temperature C, reserve output R2 will be activated

b) e.g. function: TS<... means that if the TS sensor temperature is higher then the set value in S52 parameter – Temperature C, reserve output R2 will be deactivated

c) e.g. function: TS, TV>... means that if the TS and TV sensor temperature is higher at the same time then the set value in S52 parameter – Temperature C and S54 – Temperature D, reserve output R2 will be activated (Temperature C = first position (TS), Temperature D = second position (Tv))

d) e.g. function TS, TK<... means that if the TS and TK sensor temperature is higher at the same time then the set value in S52 parameter – Temperature C and S54 – Temperature D, reserve output R2 will be deactivated (Temperature C = first position (TS), Temperature D = second position (Tk))

Individual functions:

(17) TS>	(27) TS,TK>
(18) TS<	(28) TS,TK<
(19) TV>	(29) TS,TSV>
(20) TV<	(30) TS,TSV<
(21) TK>	(31) TV,TK>
(22) TK<	(32) TV,TK<
(23) TSV>	(33) TV,TSV>
(24) TSV<	(34) TV,TSV<
(25) TS,TV>	(35) TK,TSV>
(26) TS,TV<	(36) TK,TSV<

• Parameter S15 – Operation function of the burner by the two temperatures in the accumulation tank ...**(1)**

a) S15 = 1... The function is off, the burner works based on the thermoregulator on the boiler panel

b) S15 = 2... The function is activated and the pellet burner works based on the two temperatures (sensors) in the accumulation tank – TV and TS (recommended tank volume: 500 to 1000 l). The temperature of the bottom sensor (TS) is the temperature at which the burner is switched off and the fuel burns out (parameter S16).

The temperature of the top sensor (TV) is the temperature at which the burner is switched on again (parameter S17).

The burner screen displays the TV and TS temperatures.

c) S15 = 3... The function is activated and the pellet burner works based on the two temperatures (sensors) in the accumulation tank – TV and TS (recommended tank volume: 500 to 1000 l).

The temperature of the top sensor (TV) is the temperature at which the burner is switched on again.

The temperature of the bottom sensor (TS or TK) is the temperature at which the burner is stopped.

Whether the burner is switched off based on the TS or TK sensor is decided by the temperature of the solar panel (TSV) and the temperature in the lower part of the accumulation tank (TS), where a solar exchange is built-in. If the solar panel can efficiently heat up water in the accumulation tank, the burner is turned off based on the TK sensor, so that the tank can store energy from the sun.

If the energy delivered from the solar collector drops below a certain limit (temperature), the deactivation logic of the burner is automatically switched back to be based on the TS sensor (S26 = 1).

However, it is possible to set that the switching may only occur after a certain period of time (S29 = 2nd digit means the length of delay between switches, in hours). Another variant is to have the burner work permanently based on the TV and TK temperatures (S26 = 0).

d) S15 = 4... The function is off and the burner works based on the TK temperature, protected by the thermoregulators on the boiler panel. After this function is activated, we need to check and possibly setup its temperature parameters S18 and S19.



CAUTION - if S15 = 2 not possible to set S6 = 14 a S14 = 14.

If S15 = 3 not possible to set S6 = 11, S14 = 11, S6 = 12, S14 = 12, S6 = 13, S14 = 13.

If S15 = 1, S15 = 4 not possible to set S14 = 14.

• **Parameter S16** - Temperature of the top sensor (TV) at which the burner is started... **(60 °C)**

It is the minimum temperature of water that can be reasonably utilized in the heating system.

• **Parameter S17** - The temperature of the bottom sensor (TS, or TK for S15 = 3) at which the burner is stopped... **(75 °C)**

It is the maximum temperature of water that corresponds to requirements of the heated building and the designed heat exchangers in the system (radiators and floor heating).



CAUTION – Do not set this value too high to avoid disconnection of the safety thermostat on the boiler. **Always set the control thermostat on the boiler to the maximum value (95 °C).** If the control thermostat on the boiler intervenes before the burner is switched off by the signal of the TS sensor in the bottom part of the accumulation tank, the system probably finds itself in the state of hydraulic imbalance and you should check and adjust it. You can e.g. throttle the shortcut in the boiler circuit or the return line from the heating system towards the accumulation tank.

• **Parameter S18** – describes the required temperature of boiler TK, which the burner is switched off at if S15 = 4... **(85 °C)**

• **Parameter S19** - difference between TK temperature (for re-starting the burner) for S15 = 4... **(5 K)**

• **Parameter S24** – maximum flue gas temperature... **(250 °C)**

If you connect a **flue gas temperature sensor at the position of sensor TS** to the burner and in a mode of the burner this limit value is exceeded, a warning message will appear on the display. It will notify the operator of the necessity to clean the heat exchanger of the boiler or the installer of the necessity to reduce the burner power to avoid **unnecessary wasting of fuel. The operation of the burner is not limited by this message in any way** and to clear the message **you can just switch off and on** the main switch on the boiler.

• **Parameter S26** – is the function for defining the logic of deactivating the burner based on the TS or TK sensor, when S15 = 3. Connection of the boiler with a tank equipped with a solar exchanger... **(1)**

a) S26 = 0... The burner permanently works based on the upper TV sensor (activation temperature) and via the TK sensor (deactivation temperature). The lower part of the tank permanently has enough room for energy from the solar collector (TS sensor)

b) S26 = 1... the burner permanently works based on the upper TV sensor (activation temperature) and the configured logic automatically takes care of switching between the middle TK sensor and lower TS sensor. Whether the burner is deactivated based on TS or TK is decided based on the temperature on the solar panel (TSV) and the temperature on the lower part of the accumulation tank (TS), where the solar exchanger is located. If the solar panel can efficiently heat up water in the accumulation tank, the burner is turned off based on the TK sensor, so that the tank can store energy from the sun.

• **Parameter S27** - activation difference of function S26 = 1... **(10 K)**

If the temperature on the solar panel (TSV) exceeds the temperature in the lower part of the tank by the activation difference, the boiler deactivation function will be switched from the bottom TS sensor to the middle TK sensor.

If a function for solar panel pump control is activated directly from the boiler regulation (S6 = 14 or S14 = 4), the same logic will be used to activate the solar pump.

• **Parameter S28** – deactivation difference of function S26 = 1... **(3 K)**

If the temperature on the solar panel (TSV) exceeds the temperature in the lower part of the tank by the deactivation difference, the boiler deactivation function will be switched from the middle TK sensor to the bottom TS sensor.

If a function for solar panel pump control is activated directly from the boiler regulation (S6 = 14 or S14 = 4), the same logic will be used to activate the solar pump.

• **Parameter S29** – is the function for delaying the automatic switching from the TK sensor back to the TS sensor for controlling the burner based on two temperatures (function S15 = 3)... **(0 hours)**

This function will cause the function for deactivating the burner to be switched from the middle TK sensor to the bottom TS sensor after the time listed in parameter S29 passes, if the temperature on the solar panel TSV is lower or greater only by the deactivation difference (Parameter S28) than the temperature in the lower part of the tank where the solar exchange is located.

The set value means the number of hours, e.g.: S29 = 2 means a switch delay of 2 hours.

• **Parameter S30** – is the function of the minimal operating time of the solar pump when the conditions for its activation and then deactivation are met (function S15 = 3)... **(3 min)**

The set value means the number of minutes, e.g.: S30 = 3 means 3 minutes

• **Parameter S31** – characterizes the required temperature TS in the lower part of the accumulation tank where the solar exchanger is located, during the function of charging the accumulation tank by the solar collector. (function S15 = 3)... **(75 °C)**

Once it is reached, the solar pump will be turned off.

• **Parameter S32** – characterizes the maximum temperature TV in the accumulation tank during the function of charging the accumulation tank by the solar collector (function S15 = 3)... **(100 °C)**

The solar pump will be turned off if it is exceeded.

• **Parameter S33** – characterizes the maximum temperature TSV of the solar collector, for which the solar pump will still remain in operation (function S15 = 3)... **(115 °C)**

The solar pump will be turned off if it is exceeded.

• **Parameter S34** – is the function of automatically starting the pellet burner (AUTOSTART) after the wood burns out. The function is specially created for DCxxSP(X), CxxSP, ACxxSP, DCxxGSP burners, however it may also be used for two separate boilers... **(0) It is not standardly used with the A45 burner.**

a) **S34 = 0**.... The automatic start function is off

b) **S34 = 1**.... The automatic start function is on. The pellet burner will be turned on when the temperature of exhausts TSV drops below the set value (S36 = 80), e.g. below 80 °C

c) **S34 = 2**.... The automatic start function is on. The pellet burner will be turned on when two conditions are met:

- the temperature of the boiler TK drops below the set value (S35 = 75), e.g. below 75 °C
- the temperature of exhausts TSV drops below the set value (S36 = 80), e.g. below 80 °C

If the function (parameter S34) is turned on in the boiler, the following practice is used for boilers DCxxSP(X), CxxSP, ACxxSP:

If the boiler is burning out but the wood container still contains enough wood, we may directly **switch the boiler switch from wood to pellets.**

The pellet burner will perform a **DIAGNOSTIC** which will be used to ascertain the current status of the boiler (temperature of exhausts, temperature of the boiler, temperature in the accumulation tank)

If the conditions for immediate start of the burner are not met (see above), the burner will remain on standby, where the flue exhaust fan will remain in operation (if set) so that the wood can properly finish burning (S6 = 4). **AUTOSTART will start flashing on the boiler screen.**

If the **AUTOSTART sign flashes slowly**, the conditions set by the function (S34 = 1 or S34 = 2) are not met.

If the **AUTOSTART sign flashes quickly**, the previous conditions are met, but the conditions set by function (S15 = 2) are not, which means that the temperature on the accumulation tank did not drop below the value set by S16 or the regulation thermoregulator on the boiler is not activated, i.e. the end switch is not pressed (a star is not displayed on the boiler screen near the thermoregulator symbol)

If all the conditions are met, the burner will start automatically.



INFO – In case of an electric outage, the burner will perform a DIAGNOSTIC and, if all conditions are met, will burn out and return to normal operation. Otherwise it will await the fulfillment of previous conditions (drop of exhaust and water temperature).

If we want to use wood to heat up the boiler, it suffices to place the switch on the wood position. However, it is better to first keep the switch on the „0“ position for 10 - 15 minutes so that the burner can properly burn out. This is an ideal time to prepare the fuel for stoking.



WARNING – DCxxSP(X)/(EP), CxxSP, ACxxSP boilers do not allow you to control the solar heating function directly from the pellet burner. Additionally the TK and TSV sensors are used for measuring the temperature of the boiler and exhausts during this function.

• **Parameter S35** – characterizes the limit (max.) temperature of the boiler TK, during which the burner will automatically start during the AUTOSTART function (S34 = 2)... **(75 °C)**

• **Parameter S36** – characterizes the limit (max.) temperature of the exhausts TSV, during which the burner will automatically start during the AUTOSTART function (S34 = 2)... **(80 °C)**



WARNING – after placing the exhaust sensor TSV on a side of the burner flue pipe, the TSV temperature is not the exact temperature of the exhausts but the difference temperature for the automatic start function. If we want to place the exhaust sensor directly on or into the flue pipe to measure the exhaust temperature precisely, it is necessary to always use a sensor with a higher heat resistance of up to 400 °C.

• **Parameter S37** – characterizes the requires temperature of the boiler TK during which the pump in the boiler circuit will be activated. This will only occur if the required temperature is reached and the boiler is in OPERATION or burn-out mode (S14=13 with modules AD02 or AD03)... **(75 °C)**
It is also necessary to re-check or set parameters S38, S39, S40

- **Parameter S38** – deactivation difference for parameter S37, of the pump in the boiler circuit (S14 = 13 or S6 = 13)... **(2 K)**

If the temperature of the boiler TK drops by more than the deactivation difference S38, the pump in the boiler circuit will be turned off in the OPERATION or STOP (burn-out) modes.

- **Parameter S39** – characterizes the emergency temperature of the boiler TK, during which the pump in the boiler circuit will be activated (S14 = 13 with modules AD02 or AD03)... **(93 °C)**

Activation will be carried out regardless of special functions of the burner (function S40). The function works based on the deactivation difference specified in parameter S38.

- **Parameter S40** – is the function for after-running of the pump in the boiler circuit used based on boiler type (S14 = 13, S6 = 13)... **(0)**

a) S40 = 0... The automatic deactivation function for the pump in the the boiler circuit after the pellet burner burns out is off (after the time specified in parameter T5 runs out). The pump will be switched off after the temperature of the boiler TK drops (S38, S39). Designated for ceramic boilers with a large momentum (with the option of stoking with wood).

b) S40 = 1... The automatic deactivation function for the pump in the boiler circuit after the pellet burner burns out is on. The pump will be switched off immediately after the burner burns out, after the time specified in parameter T5 runs out. The function designated by parameter S39 is active. Designated for boilers with minimal momentum without ceramics (D31P, P31, DCxxSP(X)(T) and DCxxGSP).

- **Parameter S41** – is the function for automatic cleaning of the burner by compressed air after a certain number of work cycles (burn-outs). The function utilizes both reserve outputs (S16 = 15, S14 = 16 (S67 = 15, S68 = 16 in case of AC07X-C module)) – nonstandard function... **(4)**

a) S41 = 1 - 9... function when the cleaning of the burner will be performed only once after running a given number of cycles (1, 2, 3, 4, 5, 6, 7, 8, 9 - number of cycles)

b) S41 = 11 - 19... function when the cleaning of the burner will be performed always twice after running a given number of cycles (11 = 1, 12 = 2, 13 = 3, 14 = 4, 15 = 5, 16 = 6, 17 = 7, 18 = 8, 19 = 9 - number of cycles) (from 1. 4. 2013)

If the parameter S41 = 0 or 10, the function is turned off.

- **Parameter S42** – is the function for automatic burner cleaning with compressed air after a specific period of operation time has passed (in one cycle). Once the subsequent working cycle has ended (burn-out), the burner tubing is cleaned. The function assumes use of both reserve outputs (S6 = 16, S14 = 15 (S67 = 15, S68 = 16 in case of AC07X-C module)) – non-standard function... **(6 hours)**
The value set is the actual time in hours.

- **Parameter S43** – is the function for automatic burner cleaning with compressed air after a specific period of operation time has passed. Once the set time has passed, the burner immediately burns out (AUTOSTOP), it is cleaned and once again run. If required at all requirements for START are met. (regardless of S41 and S42 parameters). The function assumes use of both reserve outputs (S6 = 16, S14 = 15 (S67 = 15, S68 = 16 in case of AC07X-C module)) – non-standard function... **(12 hours)**

This is the sum of operating hours of all completed cycles.

The value set is the actual time in hours.

• **Parameter S44** – is the compressor function for automatic cleaning of the burner by compressed air, which determines the duration of compressor operation used for preparing a sufficient amount of compressed air (pressure function S6 = 15) - nonstandard function... (**2 min**)

The set value represents the actual time in minutes.

• **Parameter S45** – is the electric valve function for automatic cleaning of the burner by compressed air, which determines how long the el. valve is open to perfectly clean the combustion chamber of the burner (S14 = 16) - nonstandard function... (**2 s**)

The set value represents the actual time in seconds.

• **Parameter S46** – is the burner fan function which sets the type of used fan with rotation scanning. Number of impulses... (**12-EBM**)

• **Parameter S47** – is the function of fan 2 which sets the type of used fan with rotation scanning. Number of impulses – **do not change the factory setting...** (**0**)

a) **S47 = 12** - EBM..... radial blower of the burner

b) **S47 = 4** - ATAS..... exhaust blower of the boiler

c) **S47 = 0**..... second method for switching off the blower 2 speed sensing

• **Parameter S48** – characterizes temperature **TEMPERATURE A** in the applications of function S6 = 17 to 36... (**75 °C**)

This is a free function for the reserve output R (R5) on the first position (Temperature A = first position in function S6 = 17 to 36).

• **Parameter S49** – characterizes the activation or deactivation difference for **TEMPERATURE A** in the applications of function S6 = 17 to 36... (**5 K**)

This is the difference for the free function of reserve output R (R5) on the first position (difference for Temperature A = difference for the first position in the function S6 = 17 to 36).

• **Parameter S50** – characterizes **TEMPERATURE B** in the applications of function S6 = 25 to 36.....(**75 °C**)

This is a free function for the reserve output R (R5) on the first position (Temperature b = second position in function S6 = 25 to 36).

• **Parameter S51** – characterizes the activation or deactivation difference for **TEMPERATURE B** in the applications of function S6 = 25 to 36... (**5 K**)

This is the difference for the free function of reserve output R (R5) on the first position (difference for Temperature B = difference for the first position in the function S6 = 25 to 36).

• **Parameter S52** – characterizes **TEMPERATURE C** in the applications of function S6 = 25 to 36..... (**75 °C**)

This is a free function for the reserve output R2 (R6) on the first position (Temperature b = second position in function S14 = 17 to 36).

• **Parameter S53** – characterizes the activation or deactivation difference for **TEMPERATURE C** in the applications of function S14 = 17 to 36... (**5 K**)

This is the difference for the free function of reserve output R2 (R6) on the second position (difference for Temperature C = difference for the second position in the function S14 = 17 to 36).

- **Parameter S54** – characterizes **TEMPERATURE D** in the applications of function S14 = 25 to 36.... **(75 °C)**

This is a free function for the reserve output R2 (R6) on the first position (Temperature b = second position in function S14 = 25 to 36).

- **Parameter S55** – characterizes the activation or deactivation difference for **TEMPERATURE D** in the applications of function S14 = 25 to 36... **(5 K)**

This is the difference for the free function of reserve output R2 on the second position (difference for Temperature D = difference for the second position in the function S14 = 25 to 36).

- **Parameter S56** – characterizes control of functioning (speed sensing) of the exhaust blower of the boiler (blower 2); setting may be different according to use – **must never be changed... (0)**

a) **S56 = 0** **control of the exhaust blower of the boiler turned off**

b) **S56 = 1** **control of the exhaust blower of the boiler turned on**

If S56 = 1, parameters S47 and S57 are activated (visualized).

- **Parameter S57** – characterizes minimum (safety) speed of the blower 2... **(1.000 rpm) - not change** adjustable range 1.000 – 3.200 rpm

It is a function of the control of proper functioning of the exhaust blower of the boiler.

When the blower is running at the speed lower than set, “ALARM VENT 2” is declared.

- **Parameter S58** – characterizes the amount of compressed air for the first pre-cleaning of the burner when installing pneumatic cleaning the burner. This is the time at which the partial filling compressor air tank for pre-cleaning of the burner ... **(6 s) - standardly do not change**

- **Parameter S59** - characterizes the amount of compressed air for the second pre-cleaning of the burner when installing pneumatic burner cleaning. This is the time at which the partial filling compressor air tank for pre-cleaning of the burner... **(OFF) - standardly do not change**

Adjustable range...OFF, 1 - 120 s.

- **Parameter S60** - characterizes the amount of compressed air for the third pre-cleaning of the burner when installing pneumatic burner cleaning. This is the time at which the partial filling compressor air tank for pre-cleaning of the burner... **(OFF) - standardly do not change**

Adjustable range... OFF, 1 - 120 s.

- **Parameter S61** - characterizes the function for control of the boiler exhaust fan from the outlet for the burner discharge fan via the AD04 module. The function is intended for models DCxxSP(X), CxxSP, ACxxSP without flap with actuator fitted with the pneumatic burner cleaning options and the activated function for automatic start of the burner following wood burnout - AUTOSTART... **(0)**

a) **S61 = 0**..... function OFF

b) **S61 = 1**..... function ON (for for profile A45 pneu)

Never activate this function for boilers DCxxGSP and DCxxSP(X), CxxSP, ACxxSP (Model since 2018 equipped with flap with actuator).

• **Parameter S62** – characterizes the function for control of the air valve (flap) with actuator (servo drive) located in the pellet burner. This valve is operated from the outlet of the burner discharge fan via the AD04 module integrated in the burner (from serial production - default configuration) and subsequently via the AD08 module from the default configuration under the DCxxGSP boiler hood. The function is intended for models DC40SPT, DC40GSP (Model since 2018)... **(1)**

a) **S62 = 0...** function OFF (for burners without flap with actuator)

b) **S62 = 1...** function ON (for burners with flap with actuator - for models DCxxGSP and DCxxSP(X) (T), CxxSP, ACxxSP (Model since 2018))

(Burners equipped with internal flap with actuator with AD04 module and the third (additional) 2-pins connector.)

• **Parameter S63** – characterizes the function of start delay of the pellet burner (AUTOSTART), with function of automatic burner start after burnout of the wood. Start delay of the pellet burner we use in case, that the operator wants to switch the selector switch from the position - wood to the position - pellets immediately after firing up without waiting till the boiler ran at nominal output (TSV and TK temperatures not reached). This will always delay the start of the burner 60/120/180/240 minutes. When activating this function the display of the burner shows the time remaining until the automatic start of the pellet burner (cold condition) or until the change to the normal function of automatic start characterized with the parameter S34.

In case of that the operation waste gas temperature will be reached (parameter S36 = TSV + 20 K) ends the countdown of the automatic start and the burner goes directly to normal auto start (parameter S34).

a) **S63 = OFF...** function switched off - factory setting

b) **S63 = 1...** start delay of 1 hour (60 min) - recommended setting

c) **S63 = 2...** start delay of 2 hour (120 min)

(Setting possibility S63 = OFF, 1 (60 min), 2 (120 min), 3 (180 min), 4 (240 min))

This special function is active in the program version 38 and newer.



INFO - when putting burner into operation with activated function S63 = 1 (or 2, 3, 4) the plumber may once enter the code 1111 and to skip from AUTOSTART directly to the burner START (TSV and TK below than defined).

• **Parameter S64** - characterizes the temperature of flue gas inside the heat exchanger of the boiler. It serves to diagnoses the absence of pellets in the boiler tank or shows low output of the boiler. It is not temperature of flue gas. Function is only for DxxPX (PXxx) boilers, burner profile A25PX. **Do not change... (130 °C)**

• **Parameter S65** - characterizes start up time of the burner in OPERATION mode during which has to be reached minimal waste gas temperature in the heat exchanger of the boiler set by parameter S64.

If in this time the boiler does not reach temperature the display shows **ALARM SETTINGS – REFILL PELLETS**. In such case check the set output in parameters T4 and T6 and increase it.

In case of low pellets level in the tank fill up the fuel. Function is only for DxxPX (PXxx) boilers, burner profile A25PX. **Do not change... (120 min)**

- **Parameter S66** - characterizes run-out time of the burner in OPERATION mode during which the burner stays in operation when waste gas temperature in the heat exchanger of the boiler descend under the temperature characterized by the parameter S64.

After the time characterized by the parameter S66 is display **ALARM PELLETS – REFILL PELLETS**. In this case check the pellet tank and fill up the fuel.

DxxPX (PXxx) boilers are designed that after fuel refill is necessary only to turn off and on the main switch on the boiler. So it is not necessary fill up the pellets into the conveyor after shown **ALARM PELLETS – REFILL PELLETS**.

Function is only for DxxPX (PXxx) boilers, burner profile A25PX. **Do not change... (30 min)**

- **Parameter S67** - characterizes function of **R5 reserve** output similar with S6 and S14 parameters with installed AC07X-C additional module. Primary is this reserve used to control air pump for pellet burner pneumatic ash cleaning system S67 = 15.

Function is only for DC40GSP and DC40SPT boilers or burners equipped with additional AC07X-C module, burner profile A45GSP (A45GSP pneu) and A45SP (A45SP pneu)..... **(0)**

if:

a) **S67 = 1...** If any fault occurs in the burner and the burner is shut down, **the reserve relay will be closed and the reserve output will be energized**. Thanks to this you can start a spare source of energy for heating of the building as e.g. a gas, electric or oil boiler.

b) **S67 = 2...** If any fault occurs in the burner and the burner is shut down, **the reserve relay will be opened and the reserve output will not be energized**. Thanks to this a signal can be sent to an electrically backed up device (GSM, Wifi,...) that will send information that there is a system fault or the system is not energized. **This is the opposite logic (to S6 = 1), which means that during normal operation the reserve is energized**.

c) **S67 = 4...** The reserve function as the **reversed function of the output for the burner fan**, when the reserve **output is off, is not energized always when the burner fan is running**. This function is always activated if we want the exhaust fan of the DC40GSP and DC40SPT boilers runs together with pellet burner.

AD08 module is installed under the DC40GSP boiler instrumental hood for this function, see electrical scheme.

AD03 module is installed under the DC40SPT boiler instrumental hood for this function, see electrical scheme.

This setting and connection with AD02 or AD03 (AD08) module and special connector (jumper to main switch) is **standardly used for DCxxGSP (DCxxSP(X)) boilers with the function for automatic start after wood is burnt out activated (AUTOSTART – S34 = 1 or S34 = 2). Boiler exhaust fan is running simultaneously with the pellet burner during the AUTOSTART function.**

d) **S67 = 7...** Reserve function as **the output function for the external worm conveyor**, when the reserve copies the run of the external worm conveyor (cycles between time T4 and T6). **The reserve output work independently** of the condition of the actual output for the external worm conveyor. This means that if the standard output for the external conveyor gets damaged, the reserve will work independently in accordance with the same program, and therefore it can be used as a replacement for the damaged output.

e) **S67 = 8...** Reserve function as **the output function for the external worm conveyor**, when the reserve copies the run of the external worm conveyor (cycles between time T4 and T6). **The reserve works in dependence on** the status of the actual output for the external worm conveyor. This means that if the output for the external conveyor gets damaged, the reserve will be switched off automatically. This function is suitable in situations when you need to control another external conveyor that supplies (feeds) pellets from a larger distance to the main conveyor from which the pellets fall directly to the burner.

f) **S67 = 15...** Reserve function for the compressor control during the function for automatic burner cleaning using compressed air. Power element designed for switching and powering the compressor (e.g. contactor) must be connected between reserve output R5 and the compressor. This function is connected with S68, S41, S42, S43, S44, S45, S46, S47 parameter, which must be checked and configured.

g) **S67 = 16...** Reserve function for controlling el. fan during the function for automatic burner cleaning using compressed air. This function is connected with S68, S41, S42, S43, S44, S45, S46, S47 parameter, which must be checked and configured.

Special function for turning on reserve output R5 according to the temperature of a concrete sensor:

a) **e.g. function:** TS>..... means that if the TS sensor temperature is higher then the set value in S48 parameter – Temperature A, reserve output R5 will be activated

b) **e.g. function:** TS<..... means that if the TS sensor temperature is higher then the set value in S48 parameter – Temperature A, reserve output R5 will be deactivated

c) **e.g. function:** TS,TV>..... means that if the TS and TV sensor temperature is higher at the same time then the set value in S48 parameter – Temperature A and S50 – Temperature B, reserve output R5 will be activated (Temperature A = first position (TS), Temperature B = second position (Tv)).

d) **e.g. function:** TS,TK<..... means that if the TS and TK sensor temperature is higher at the same time then the set value in S48 parameter – Temperature A and S50 – Temperature B, reserve output R5 will be deactivated (Temperature A = first position (TS), Temperature B = second position (Tk)).

Individual functions:

- | | | |
|-----------|--------------|--------------|
| (17) TS> | (24) TSV< | (31) TV,TK> |
| (18) TS< | (25) TS,TV> | (32) TV,TK< |
| (19) TV> | (26) TS,TV< | (33) TV,TSV> |
| (20) TV< | (27) TS,TK> | (34) TV,TSV< |
| (21) TK> | (28) TS,TK< | (35) TK,TSV> |
| (22) TK< | (29) TS,TSV> | (36) TK,TSV< |
| (23) TSV> | (30) TS,TSV< | |

• **Parameter S68** - characterizes function of **R6 reserve** output similar with S6 and S14 parameters with installed AC07X-C additional module. Primary is this reserve used to control electric valve for pellet burner pneumatic ash cleaning system $S68 = 16$.

Function is only for DC40GSP and DC40SPT boilers or burners equipped with additional AC07X-C module, burner profile A45GSP (A45GSP pneu) and A45SP (A45SP pneu)... **(0)**

if:

a) **S68 = 1**... If any fault occurs in the burner and the burner is shut down, **the reserve relay will be closed and the reserve output will be energized**. Thanks to this you can start a spare source of energy for heating of the building as e.g. a gas, electric or oil boiler.

b) **S68 = 2**... If any fault occurs in the burner and the burner is shut down, **the reserve relay will be opened and the reserve output will not be energized**. Thanks to this a signal can be sent to an electrically backed up device (GSM, Wifi,...) that will send information that there is a system fault or the system is not energized. **This is the opposite logic (to S14 = 1), which means that during normal operation the reserve is energized.**

c) **S68 = 3**... The reserve **function as the output function for the burner fan**, when the reserve **output is closed, is energized always when the burner fan is running** (fan mode only 100 % or OFF). This function is applied if you want the boiler fan or extraction fan in the chimney to run together with the burner fan. This function is designed for direct control of an fan directly from the burner (e.g. DxxPX, PXxx).

d) **S68 = 9**... Reserve function as **the output function for the external worm conveyor**, when the reserve copies the run of the external worm conveyor, but with the difference that it **does not cycle, but runs permanently both during the drawing of the ignition amount and during both the times T4 and T6**. Thus, the other external conveyor runs continuously and **works independently** of the status of the actual output for the external worm conveyor. This means that if the output to the main external conveyor from which pellets directly fall to the burner gets damaged, **the reserve will keep working independently**. This function can be used in cases when you need to control another external conveyor that supplies (feeds) pellets **from a larger distance to a pellet bin at the boiler** from which the main external conveyor draws pellets to supply them directly to the burner. **Caution** - the other external conveyor must always be controlled with an additional level sensor (level meter) that will maintain the level of pellets in the pellet bin at the boiler.

e) **S68 = 10**... Reserve function as the output **function for the external worm conveyor**, when the reserve copies the run of the external worm conveyor, but with the difference that it **does not cycle, but runs permanently both during the drawing of the ignition amount and during both the times T4 and T6**. Thus, the other external conveyor runs continuously, but it **works in dependence on** the status of the actual output for the external worm conveyor. This means that if the output for the external conveyor from which pellets fall directly to the burner gets damaged, the reserve will be switched off automatically. This function is convenient in cases when you need to control another external conveyor that supplies (feeds) pellets **from a larger distance to a pellet bin at the boiler** from which the main external conveyor draws pellets to supply them directly to the burner. **Caution** - the other external conveyor must always be controlled with an additional level sensor (level meter) that will maintain the level of pellets in the pellet bin at the boiler. This is a similar function to $S6 = 9$, but with a higher degree of safety.

f) S68 = 11... Reserve function for controlling boiler exhaust fan for DC40GSP and DC40SPT boiler types when the function for automatic start after wood is burnt out is activated. This function ensures that boiler exhaust fan is running only during wood burning after the wood is burnt out. When the burner is run on pellets, the boiler exhaust fan remains switched off. This function is used if you do not need or want to use the boiler exhaust fan while the burner is running. **Install the special connector (jumper to main switch) AD02 and AD03 (AD08) module under the instrument hood of the boiler and connect it electrically between the boiler terminal board and the extraction fan, see the wiring diagram.** (with DC40GSP and DC40SPT we do not instal). **It is not standardly used with the A45 burner.**



WARNING – this is not a standard setting for DC40GSP and DC40SPT boilers with the function of automatic start (AUTOSTART – S34 = 1 or S34 = 2) after wood is burnt out (standard setting is S14 = 13).

g) S68 = 12... Reserve function for direct control of pump in the boiler circuit from the burner regulation (boiler terminal board). This function controls the pump in the boiler circuit without using AD02 or AD03 modules. This is applicable only for boilers that do not allow heating with wood (not even in emergency situations). E.g. D14P, P14, D21P, P21, D25P, P25, DxxPX, PXxx. Pump output must be switched to reserve R5 on the boiler terminal board and the TK sensor must be installed before this function can be activated. After activation, S37, S38, S39, S40 temperature parameters must be checked and configured.

h) S68 = 13... **Reserve function is the reverse output function** for controlling the pump in the boiler circuit from the burner regulation (output cable from boiler with a connector – white inside) via AD02, AD03 or AD08 modules. This function controls the pump in the boiler circuit using AD02, AD03 or AD08 modules ranged into a set with pump thermostat installed into the boiler panel. **This method of pump controlling can be used for any ATMOS pellet boiler, and is therefore recommended.** AD02, AD03 (AD08) modules must be inserted and connected under the boiler hood and the TK sensor must be installed before this function can be activated. After activation, S37, S38, S39, S40 temperature parameters must be checked and configured.

i) S68 = 14... Reserve function for direct control of solar heating pump from the burner regulation (boiler terminal board). This function control solar pump when automatic sensor switching function is activated (S15 = 3), where the boiler is connected with accumulation tank equipped with solar exchanger and collectors. The system requires TV, TK, TS and solar sensors to be connected to the TSV solar panel. This function never uses AD02 or AD03 modules. After activation, S26, S27, S28, S29, S30, S31, S32, S33 temperature parameters must be checked and configured.

This function is specially designed for boilers: D14P, P14, D15P, P15, D20P, P20, D21P, P21, D25P and P25



CAUTION - the direct controlling function of solar heating from pellet burner cannot be used for DC40GSP and DC40SPT boilers and boilers with burner built into the upper doors. This function also cannot be used when the pump is simultaneously controlled in the boiler circuit from the burner regulation (TK sensor cannot be simultaneously in boiler and accumulation tank)

j) S68 = 16... Reserve function for controlling el.fan during the function for automatic burner cleaning using compressed air. This function is connected with S67 (S68), S41, S42, S43, S44, S45, S46, S47 parameter, which must be checked and configured.

Special function for turning on reserve output R6 according to the temperature of a concrete sensor:

a) e.g. function: TS>... means that if the TS sensor temperature is higher then the set value in S52 parameter – Temperature C, reserve output R6 will be activated

b) e.g. function: TS<... means that if the TS sensor temperature is higher then the set value in S52 parameter – Temperature C, reserve output R6 will be deactivated

c) e.g. function: TS, TV>... means that if the TS and TV sensor temperature is higher at the same time then the set value in S52 parameter – Temperature C and S54 – Temperature D, reserve output R6 will be activated (Temperature C = first position (TS), Temperature D = second position (Tv)).

d) e.g. function TS, TK<... means that if the TS and TK sensor temperature is higher at the same time then the set value in S52 parameter – Temperature C and S54 – Temperature D, reserve output R6 will be deactivated (Temperature C = first position (TS), Temperature D = second position (Tk)).

Individual functions:

- | | | |
|-----------|--------------|--------------|
| (17) TS> | (24) TSV< | (31) TV,TK> |
| (18) TS< | (25) TS,TV> | (32) TV,TK< |
| (19) TV> | (26) TS,TV< | (33) TV,TSV> |
| (20) TV< | (27) TS,TK> | (34) TV,TSV< |
| (21) TK> | (28) TS,TK< | (35) TK,TSV> |
| (22) TK< | (29) TS,TSV> | (36) TK,TSV< |
| (23) TSV> | (30) TS,TSV< | |

Offset TV – This function is used to compensate the offset of the TV temperature sensor (input) in the range of ± 9.9 °C.

Offset TS – This function is used to compensate the offset of the TS temperature sensor (input) in the range of ± 9.9 °C.

Offset TK – This function is used to compensate the offset of the TK temperature sensor (input) in the range of ± 9.9 °C

Offset TSV – This function is used to compensate the offset of the TSV temperature sensor (input) in the range of ± 9.9 °C

Reset – By means of this function you can use one command to reprogram the electronic unit of the burner to the default settings.

Restart – By means of this function you can use one command to reprogram the electronic unit of the burner to the settings last set by the installer (under the installer code).

This allows the resetting of the control unit without changing the system settings in case of any problems.

Calibr. – This function makes it possible to calibrate inputs for temperature sensors with the use of special calibration aids – **function for the manufacturer only.**

Language – This is the selection function of the language in which the burner communicates with the user.

The basic version of the program contains these language versions:

CZ - Czech, DE - German, EN - English, FR - French, IT - Italian, SP - Spanish, SE - Swedish, PO - Portuguese, RO - Romanian, PL - Polish, HU - Hungarian, SL - Slovenian

Module – shows actual connected additional module, e.g. AC07X-C.

Device – product type the electronic unit is designed for... **(A45)**

– shows actual set burner profile

(A25, A25 pneu, A25I, A25I pneu, A25 pneu COM, A25 GSP, A25 GSP pneu, A25 PX, A25 PX pneu, A25 SP, A25 SP pneu,

A45, A45 pneu, A45 SP, A45 SP pneu, A45 GSP, A45 GSP pneu, A85 pneu, A85 pneu C)

A25 - standard profile for ATMOS A25 burner

A25 pneu - profile for ATMOS A25 burner with pneumatic cleaning

A25I - profile for burner with unstandard fan (circuit outlet - Parameter S46 = 1-EBM)

A25I pneu - profile for burner with unstandard fan (circuit outlet) with pneumatic cleaning

A25 pneu COM - profile for burner with pneumatic cleaning for boilers DxxP, Pxx Compact (with AC07X-C)

A25 GSP - burner profile for DCxxGSP boilers

A25 GSP pneu - burner profile with pneumatic cleaning for DCxxGSP boilers

A25 PX - burner profile for DxxPX, Pxxx boilers

A25 PX pneu - burner profile with pneumatic cleaning for DxxPX, Pxxx boilers (with AC07X-C)

A25 SP - burner profile for DCxxSP boilers

A25 SP pneu - burner profile with pneumatic cleaning for DCxxSP boilers

A45 - standard profile for ATMOS A45 burner

A45 pneu - profile for ATMOS A45 burner with pneumatic cleaning

A45 SP - burner profile for DC40SPT boiler

A45 SP pneu - burner profile with pneumatic cleaning for DC40SPT boiler

A45 GSP - burner profile for DC40GSP boiler

A45 GSP pneu - burner profile with pneumatic cleaning for DC40GSP boiler

A85 pneu - profile for ATMOS A85 burner with pneumatic cleaning for D80P, P80 boilers

A85 pneu C - profile for ATMOS A85 burner with pneumatic cleaning for D85P, P85 boilers (with AC07X-C)

INFORMATION menu

- **Photocell** – Displays the **current value** that the photocell sees.
- **Temperature TS** – displays the **current TS temperature** - (exhaust temperature (S15 = 1) or lower temperature (S15 = 2))
- **Temperature TV** – displays the **current TV temperature** - (water temperature (S15 = 1) or upper temperature (S15 = 2))
- **Temperature TK** – displays the **current TK temperature** - (boiler temperature (S15 = 1, S15 = 2, S15 = 4, S6 = 12, S6 = 13, S14 = 12, S14 = 13), central tank temperature (S15 = 3, S6 = 14, S14 = 14), central tank temperature as a second deactivation sensor for burner TS2 (S26 = 0))
- **Temperature TSV** – displays the **current TSV temperature** - (exhaust temperature (S15 = 1, S15 = 2, S15 = 4, S34 = 1, S34 = 2), solar collector temperature (S15 = 3, S6 = 14, S14 = 14))
- **Fan speed** - displays the **current speed of the fan**
- **Fan speed 2** – displays the **current speed of fan 2 (not used)**
- **Conveyor** - displays the **current status of the conveyor**
- **Conveyor faults** - displays **information for the service engineer**
- **Spirals** - displays the **current status of the ignition spirals**
- **Spiral faults** - displays **information for the service engineer**
- **Reserve R** - displays the **current status of the reserve output R (parameter S6)**
- **Reserve R2** - displays the **current status of the reserve output R2 (parameter S14)**
- **Reserve R5** - displays the **current status of the reserve output R5 (parameter S67)**
- **Reserve R6** - displays the **current status of the reserve output R6 (parameter S68)**

Short explanation:

This always depends on whether the burner regulation function based on two temperatures on the accumulation tank is on or off, and whether the automatic start function after wood burns out is activated. **The default settings are S15 = 1 and S34 = 0**, which means that the **function for controlling the burner by two sensors is deactivated** and the AUTOSTART function for DCxxSP(X)/(EP), CxxSP, ACxxSP burns is also off. The burner is only controlled by thermoregulators on the boiler panel. The customer may connect the exhaust temperature sensors TS and TSV and the water temperature sensors TV and TK to the burner so that they **only serve as information**.

If we set $S15 = 2$, the function for regulation by two temperatures on the tank is activated and so we connect the water temperature sensor in the lower part of the tank TS and the water temperature sensor in the upper part of the tank TV to the clamps of the burner connector.

If we set $S15 = 3$, the function for regulation by two temperatures on the tank is also activated, simultaneously with the solar functions. It is thus also necessary to connect the TK sensor located in the middle of the accumulation tank between the TV and TS sensors and the TSV solar collector sensor.

If we are going to use the AUTOSTART function for boilers DCxxSP(X)/(EP), CxxSP, ACxxSP ($S34 = 1$ or $S34 = 2$), we must also connect the TK sensor as a boiler sensor and the TSV sensor as the exhaust temperature sensor.

If we are going to control the pump in the boiler circuit (recommended $S14 = 12$ or $S14 = 13$), we must always connect the TK sensor.

TESTING menu

- **Autotest** – This function is used for automatic testing of all the basic elements of the burner as the fan, conveyor, ignition spirals, etc. The testing is carried out consecutively in 20-second intervals so that the engineer can monitor the operation of individual devices.
If this test is not sufficient, individual devices can be run separately, namely with the use of the following functions.



CAUTION – During testing the burner is put out of operation, therefore before the start of testing always let the burner properly burn out **with the use the STOP command**.

- **Fan** - this function is used to test the operation of the fan
- **Conveyor** - this function is used to test the operation of the conveyor
- **Spiral 1** - this function is used to test the operation of the ignition spiral 1
- **Spiral 2** - this function is used to test the operation of the ignition spiral 2
- **Reserve R** – this function is used to test the switching device (relay) of the reserve output R
- **Reserve R2** – this function is used to test the switching device (relay) of the reserve output R2
- **Reserve R5** – this function is used to test the switching device (relay) of the reserve output R5
- **Reserve R6** – this function is used to test the switching device (relay) of the reserve output R6
- **Photocell** - used to test the photocell. Conduct the test by observing its sensitivity when it is inserted in the burner or outside the burner in the natural light (never on the sun – will cause an alarm).

25. Information - error messages - troubleshooting

General troubleshooting



CAUTION - All interventions into the electric systems must be performed by a qualified person that has read the operation manual and has been trained by the manufacturer.

The equipment is not working:

If you come to a boiler with a burner that has been put out of operation, proceed as follows:

- Check whether the boiler and burner are energized, if so
- Check whether the **tank is filled with pellets**
- Check whether the **conveyor is filled with pellets** after it has run out of pellets (must always be drawn before a new start, see the instructions), if so
- Read the error message on the burner display and find the error in the table below



WARNING – if the burner did not call any **ALARM**, it is not malfunctioning and is performing its own testing. Do not reset it by shutting off the power supply (switch), wait for the alarm to sound or normal operation (wait 1 hour).

Table of error messages on the display - alarms

Alarm no.	Message on the display	Meaning	Remedy
1	ALARM CRC	Wrong program checksum - error of the electronic unit	Replace the electronic control unit
2	ALARM SENSOR TV	Failure of the sensor of water temperature in the boiler or temperature in the top part of the tank (TV) - the sensor is short-circuited (damaged) or disconnected	Check the connection of the sensor in the burner Check the cable and sensor for damage Repair or replace
3	ALARM SENSOR TS	Failure of the sensor of flue gas temperature or water temperature in the bottom part of the tank (TS) - the sensor is short-circuited (damaged) or disconnected	Check the connection of the sensor in the burner Check the cable and sensor for damage Repair or replace

4	ALARM SENSOR TK	Failure of the boiler temperature sensor TK in the boiler or in the middle part of buffer tank – the sensor is short-circuited (damaged) or disconnected	Check the connection of the sensor in the burner Check the cable and sensor for damage Repair or replace
5	ALARM SENSOR TSV	Failure of the waste gas or solar sensor TSV – the sensor is short-circuited (damaged) or disconnected	Check the connection of the sensor in the burner Check the cable and sensor for damage Repair or replace
6	ALARM VENTILATOR	Failure of the fan or fan speed sensor	Check the cable of the speed sensor and its connectors Check whether the fan does not size, it must be possible to turn it easily by hand Check the fuse on the electronic board for the fan (1.0 A) Repair or replace
7	ALARM VENT 2	the same as ALARM VENTILATOR Failure of the exhaust blower of the boiler or defective capacitor under the hood of the boiler	the same as ALARM VENTILATOR Change the starting capacitor for the exhaust fan Change the exhaust fan of the boiler.
8	ALARM RELE	Error at the output for the external conveyor (neither output is functional) The external conveyor does not feed fuel to the burner	Check and if necessary replace the fuse for the conveyor (0.8 A) Check the wiring between electronic board and socket Broken gearbox of the conveyor or output for conveyor control If you are not using the reserve, reconnect the conveyor terminals to the reserve and set the parameter S6 = 7. If you use the reserve for other applications, replace the electronic control unit.

9	ALARM SPIRAL	Failure of both the ignition spirals	Check and replace both the ignition spirals and check and replace faulty fuses (3.15 A) on the electronic board Enter the activation code: 1234
---	---------------------	--------------------------------------	--



CAUTION – In case of the **ALARM SPIRAL** error message you must always replace both the ignition spirals and enter the **activation code 1234**. If after the replacement of the ignition spirals and entering of the code the burner does not ignite (no ignition element is heating), replace the AC07X electronic control unit and use the reserve output for full control of one ignition spiral. In such a case set the parameter **S6 = 5 or S14 = 5..**

10	ALARM SERVO	actuator (servo drive) failure in the burner's air flap	Check connection (FAN2 connector) between AC07X control unit, actuator (servo drive) and mechanical function of the flap. If necessary, replace the actuator (servo drive).
11	ALARM START	All the allowed start (ignition) attempts have been exhausted There are no more pellets or the bin is empty Faulty ignition spirals Faulty photocell	Replenish fuel, draw pellets to the conveyor and turn of and on the main switch on the boiler Check the supply wires of the ignition spirals, check the fuses (3.15 A), check the ignition elements with the function in the TESTING menu Check the supply cable of the photocell with the connector, test the photocell with the use of the function in the TESTING menu
12	ALARM PHOTOCCELL	Flame sensing error in the OPERATION mode	Clean the photocell If necessary, replace

<p>13</p>	<p>ALARM SAFETY</p>	<p>Disconnected end switch on the burner body</p> <p>Disconnected safety thermostat (95 °C (55 °C for boilers DxxPX, PXxx)) on the supply pipe of pellets to the burner</p> <p>Due to burning of poor-quality pellets that produce cake and prevent trouble-free burning of pellets in the burner mouth the supply hose gets subsequently clogged and the temperature at the safety thermostat rises</p> <p>Clogged flue gas exhaust from the boiler caused by obstructed flue gas ways in the boiler, flue gas duct or chimney by dust and soot; the clogging causes return flow of flue gas and heat to the pellet supply hose and subsequent disconnection of the safety thermostat.</p> <p>blown fuse for the fan (0.8A - 1.0A)</p>	<p>Properly tighten the burner to the boiler and check the contact of the end switch. Check the function of the sheet-metal stop of the end switch</p> <p>Clean the combustion chamber of the burner, if necessary, empty the supply hose of pellets, turn off and on the main switch on the boiler</p> <p>Clean the combustion chamber of the burner every day until you have good-quality pellets made of wood without bark (white pellets) that do not produce cake and where it is sufficient to clean the burner mouth once every 2 to 4 weeks</p> <p>Clean the whole boiler, flue gas duct and chimney from dust and soot, turn off and on the main switch on the boiler</p> <p>Check and change the fan with the fuse</p>
<p>14</p>	<p>HIGH FLUE TEMP.!</p>	<p>This is not an error, but a message that notifies the operator that the maximum set temperature of flue gas has been exceeded</p> <p>If this message appears when installing sensors TV and TS on the accumulation tank - it is a warning that has not yet been activated function control burner (boiler) by two sensors on the accumulation tank (S15 = 2)</p> <p>They have been interchanged on the terminal board</p>	<p>Clean the boiler and then turn off and on the main switch on the boiler to clear the error message</p> <p>S15 parameter set from the factory setting (S15 = 1) to the value S15 = 2 - turn off and on the main switch on the boiler to clear the error message</p> <p>Change the connection of the sensor on the terminal board and turn off and on the main switch on the boiler to clear the error message</p>

15	ALARM MODUL	disfunction of AC07X-C module for pneumatic ash cleaning system or other devices	Check the connector between AC07X-C and AC07X change the AC07X-C module or change the electronic control unit AC07X
16	ALARM SETTINGS - REFILL PELLETS It is not used with the A45 burner.	wrong setting of burner output due to low temp of flue gas in the heat exchanger lack of pellets in the fuel tank For DxxPX and Pxxx boilers	Change output by T4 and T6 parametres Full up pellets To reset error message turn the main switch of the boiler off and on
17	ALARM PELLETS - REFILL PELLETS It is not used with the A45 burner.	lack of pellets in the fuel tank For DxxPX and Pxxx boilers	Full up pellets To reset error message turn the main switch of the boiler off and on

EN

If you are not sure, proceed as follows:

- Check whether the worm conveyor is really working by plugging the conveyor connector directly to a wall socket, if so
- Turn off and on the main switch of the boiler and watch the lighting and flashing symbols on the display of the electronic unit. Each start over a particular symbol on the display means that the element or function is in operation or should be.

Each symbol on the display characterizes one element or function of the burner.

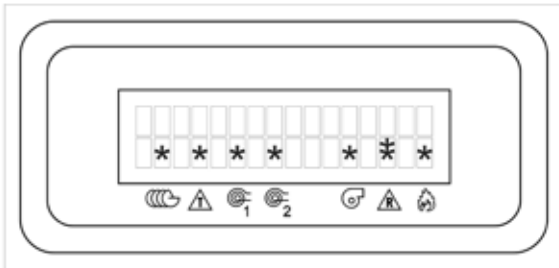

- Indicates operation of the external conveyor
- Indicates connected control thermostat of the boiler
- Indicates connected ignition spiral 1
- Indicates connected ignition spiral 2
- Indicates the fan running at the starting or operation speed
- Indicates connected reserve output R (bottom *)
- Indicates connected reserve output R2 (top *)
- Indicates that the photocell sees the flame

- If an error message related to the damage of a particular part on the burner appears immediately, you should call the customer service to replace the damaged part
- If no error message appears, you must watch and compare the function of individual elements in the burner by checking which symbol on the display is flashing or lighting up. This way you can easily locate a possible defect within the burner (faulty part).
- If the burner or boiler is not energized, check the supply cable of the boiler or the cable between the burner and the boiler



CAUTION - BEFORE OPENING THE COVER TURN OFF THE MAIN SWITCH!
Checks of live parts may only be performed by a qualified person in accordance with valid standards and laws.

Inspection procedure of the inner electric installation of the burner and boiler:

- Check whether the burner is energized
- Check whether the start signal is being sent to the burner - the control and safety thermostat is connected - L2 - the symbol on the display is lit
- Check whether the supply phase - L1 - is flowing to the burner
- Check the fuses in the electronic board for the fan, conveyor and ignition spirals
- Check the terminal board for released contact
- Check whether the ignition spiral at the start ignites (heats up) when the or symbol lights up
- Check the connection of the ignition spiral (supply wires)
- Check the connector of the supply cable of the burner for wrong connection - whether phase L1 (supply phase) is not interchanged with L2 (controlled phase) or reserve R, R2

If no problem has been found, reset the regulation AC07X by the RESTART command.

If the system is working, but you are not satisfied with its function, proceed as follows:

Check the quality of pellets

- Heating value - whether they are really pellets made of wood or whether something has been added to them - crumble them and smell
- Colour - caking - white pellets do not cake, dark pellets or pellets with dark dots that contain bark cake - in such a case the combustion chamber must be cleaned once a day!
If it is not enough to clean the combustion chamber once a day, the pellets contain chemicals which do not allow pellets to be burned in the A45 burner (biologic waste). Replacement required.
- Dust in pellets - causes uneven operation of the burner and clogging of the burner hose
- Size - too small pellets - reduce the burner power (\varnothing 5 x 5 mm), long pellets do not fall freely to the burner and clog the supply pipe.

Check the flue gas temperature

- It should be in the optimal range (150 ÷ 200 °C).
- If the temperature is too low, reduce the power of the burner (decrease parameter T4 and increase T6) and reduce the quantity of combustion air or clean the boiler.
- If the temperature is too low, increase the power of the burner and quantity of combustion air (increase parameter T4).

Check the level of pellets in the burner mouth

- If it is too low and the burner goes out, check the flue gas temperature (see above). Reduce the quantity of combustion air or increase the quantity of supplied pellets - increase the power (**increase parameter T4**).
- If the pellet level in the burner mouth is too high and the burner exhibits poor combustion - produces smoke, increase the quantity of combustion air or reduce the quantity of supplied pellets - reduce the power (**decrease parameter T4**).

At the start check how long it takes for combustion quality to improve - how long smoke is released from the chimney

- If smoke is released from the chimney at the start for more than 5 minutes, extend the time of gradual increase to the nominal power (**parameter T10**, e.g. increase by 5min). Be careful about the setting of the air flap.

The burner regularly does not ignite at the first attempt, but always at the second one

- Extend the time for the supply of ignition fuel (parameter T1 e.g. by 10 s), extend time T2 for ignition of pellets (e.g. to 12 minutes) or reduce the angle of the conveyor (max. 45°).

If after stopping of the burner and its burning out a lot of glowing unburnt pellets remain in the combustion chamber (mouth) of the burner

- Extend the rundown time of the fan - parameter T5 (e.g. extend the time by 5 minutes) - **never shorten**

26. Maintenance and cleaning of the burner

The system for burning wooden pellets is designed in such a way to require minimum maintenance. The necessary degree of maintenance directly depends on the set power of the burner and quality of used pellets.



CAUTION - Before starting repair or maintenance work during which you will handle the burner always turn off the power supply with the main switch of the boiler or disconnect to supply cable of the burner with the connector!

Regular removal of ashes:

Burning of wooden pellets leaves approximately **1 to 2 % of ashes**. In practice you will gradually find out how often the burner should be cleaned depending on the set power, intensity of heating and quality of used fuel. Before the start of cleaning you must first shut down the burner and let the fuel burn out, best by reducing the temperature on the control thermostat or by turning off the burner switch on the boiler panel. The common **interval of cleaning the burner mouth and boiler varies in the range of 7 to 30 days (after burning of 300 to 1000 kg of high-quality pellets)**. You should **remove ashes from the burner mouth by removing the combustion chamber from the burner mouth and knocking it out. Then remove ashes from the combustion space of the boiler and clean the heat exchanger of the boiler (tube plate) as described in the boiler manual.**



CAUTION - Always put ashes in a closed vessel. During the removal of ashes and cleaning of the combustion chamber use means of personal protection (gloves and protective goggles).

Annual maintenance

- At least once a year you must perform a complete check, maintenance and inspection of the burner during which the burner must be removed from the boiler.
- During this maintenance remove and wipe the photocell that senses the flame.
- Thoroughly clean the space under the combustion chamber of the burner and behind the ignition spiral. Disassemble the inlet pipe through which pellets fall to the burner and clean it.
- Dismount the covering metal sheet of the burner mouth attached with one screw and clean the space under it where pellets fall and burn (scrape off dust and deposits). Clean the opening through which the photocell sees the flame.
- Knock dust out of the flexible supply hose and visually check whether it is not perforated. In such a case repair it or replace. On that occasion check the worm of the external conveyor by inspecting it from the bottom where pellets fall into the flexible hose. Check whether is it not strangled by some objects, e.g. wound strings, a piece of wood, etc. that are sometimes found in pellets.
- Then, assemble and seat everything in the boiler. **Tighten all the connections.**

- Finally, check the basic functions and safety of the electronic unit in the **TESTING** and **INFORMATION** submenus, see page 59 and 60. Check the function of the end switch and 95 °C safety thermostat at the pellet inlet to the burner (contact of the thermostat with the pipe), see page 10 and 11.



CAUTION - It is prohibited to do welding work on the equipment if the system is connected to the electric mains and the electronic control unit is not removed. It might get damaged. If the customer is not able to carry out the annual inspection and maintenance of the burner by themselves, this service may be ordered from a service engineer. This service is subject to a fee. Make a record of the annual maintenance and inspection in the operation manual on page 73.

27. List of spare parts - burner A45

POSITION	PART DESCRIPTION	QUANTITY	CODE 1 pc
1A	Burner body - front part A45	1	H0401
1B	Burner body - rear part A45	1	H0402
2	Burner cover - hood with a window for the display - AC07X	1	H0413
3	Top cover of the burner mouth	1	H0404
4	Holder of the electronic unit	1	H0405
5	Electronic unit of the burner - AC07X with a fixation plate	1	H0222
6	Pellet supply pipe	1	H0406
7	Safety thermostat 95 °C	1	H0059
8	Safety thermostat cover	1	H0224
9	Holder - plate with openings for the ignition spirals	1	H0407
10	Ignition spiral 500 W	2	H0229
11	Ignition spiral cover	1	H0408
12	Inner holder of the ignition spiral	1	H0409
13	Combustion chamber (pot) of the burner	1	H0410
14	End switch - FR501	1	H0210
15	Burner connector - 6-pin - male - complete (power)	1	S0989
16	Burner connector - 6-pin - female - complete (sensors)	1	S0987
17	Socket for the external conveyor	1	H0211
18	Air flap of the fan	1	H0411
19	Fan with a speed sensor	1	H0041
20	Photocell - entire	1	H0231/H0330
21	Photocell holder	1	H0232
22	Electronic unit connector (1 - 12) - top	1	H0260
23	Electronic unit connector (1 - 16) - bottom	1	H0234
24	Electric harness of the burner, incl. bushings and connectors	1	H0233
25	Bushing for the cable for the end switch, safety thermostat	5	S1191
26	Gasket under the flange of the pellet supply pipe - Sibral paper	1	S0181
27	Screw for fixation of the hood 4,2 x 13 (with tip)	6	S1010
28	Screw for fixation of the burner body 4.2 x 13 (with drill)	12	S0881
29	Screw for fixation of the pneumatic cleaning lid (without tip)	3	S1028
30	Fan attachment screw M4 x 8	4	S1002
31	Screw for attachment of the pellet supply pipe M5 x 10	3	S0879
32	Screw for attachment of the safety thermostat cover M4 x 6	1	S0878
33	Screw for attachment of the end switch and safety thermostat cover M4 x 30	3	S0877
34	Screw for attachment of the conveyor socket and fan flap 3.9 x 9.5	6	S0876
35	Screw for top cover and ignition spiral plate M6x10 (stainless)	3	S0880
36	Nut M6	4	S0798
37	Display self-sticking label	1	H0236
38	End switch stop	1	H0412
39	Sealing for photocell Ø 8/15	1	S0155
40	Sealing under fan 84 x 94	1	S0157
41	Gasket under cover (lid) of the opening for pneumatic clening	1	S1031
42	Cover (lid) of the opening for pneumatic clening	1	S0996
-	Fuse for ignitaton spiral - type F 3.15A/1500A/5x20 mm	2	H0238
-	Fuse for conveyor - type F 0.8A/1500A/5x20 mm	1	H0239
-	Fuse for fan - type F 1.0A/1500A/5x20 mm	1	H0251

28. Expanded view of the A45 burner

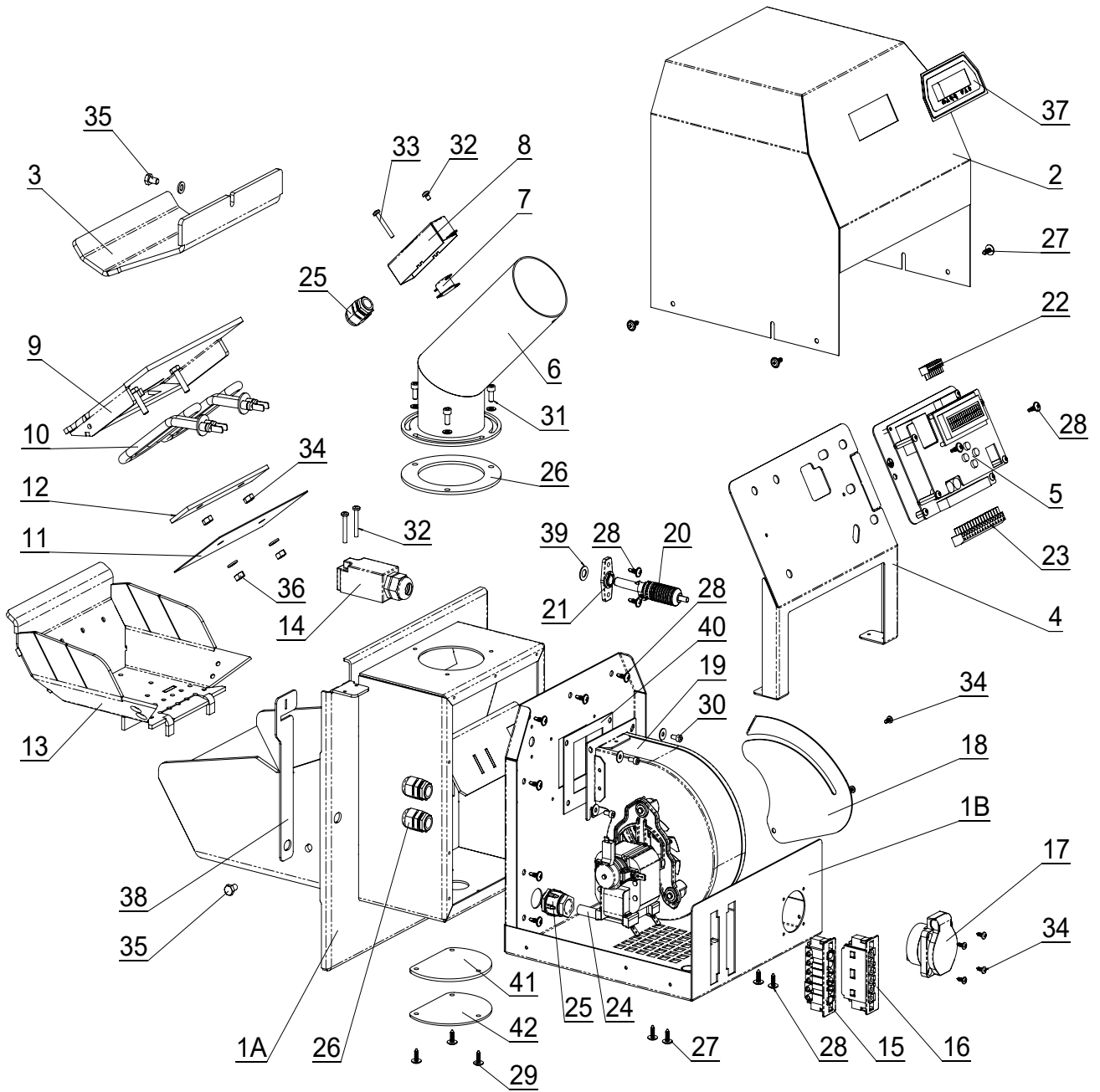

EN

GUARANTEE TERMS

1. On condition of observance of the way of use, operation and maintenance described in the manual we guarantee that the product will have the characteristics defined by the relevant technical standards and conditions for the whole guarantee period, namely for 24 months from acceptance by the consumer and max. 32 months from the date of sale by the manufacturer to the sales representative.
2. If the product exhibits a defect in the guarantee period that was not caused by the user, the product will be repaired free of charge for the customer within the guarantee terms.
3. The guarantee period will be extended by the time period for which the product was repaired.
4. The customer shall submit claims for guarantee repairs to the customer service.
5. The guarantee for the burner is only valid if the assembly of the burner and boiler was performed by a person trained by the manufacturer in accordance with valid standards and the operation manual. A condition for acknowledgment of any guarantee is legible and complete filling-in of data about the company that carried out the installation. If the burner gets damaged due to inexpert damage, the resulting costs will be borne by the company that carried out the assembly.
6. The buyer has been provably instructed how to use and operate the product.
7. Requests for repairs after the expiration of the guarantee period are also directed by the customer to the customer service. In this case the costs of the repair are borne by the customer.
8. The user is obliged to observe instructions in the operation and maintenance manual. In case of non-observance of the operation and maintenance manual, careless or inexpert handling or burning of prohibited fuel the guarantee becomes invalid and repairs of possible damages are paid by the customer.
9. At least once a year the burner must be completely inspected, checked and cleaned by a specialized company, which will confirm all the performed work in the operation manual on page 74 and further.



Guarantee and after-guarantee repairs are provided by:

-The company that represents the ATMOS Company in the particular country for the particular region

-The assembly company that installed the product

-Jaroslav Cankař a syn ATMOS,

Velenského 487, 294 21 Bělá pod Bezdězem, Czech Republic, phone +420 326 701 404

RECORD OF INSTALLATION OF THE BOILER AND BURNER

The installation was performed by:

Company:

Street: Town:

Telephone: Country:

Ascertained data:

Chimney:

Flue-gas duct:

Dimensions: Diameter:

Height: Length:

Chimney draught:* Number of elbow pieces:

Date of last inspection: Waste gas temperature:*

Boiler connected with mixing valves and fittings (brief description of connection):

.....

.....

.....

.....

Fuel:

Measured data:

Type: Waste gas temperature: °C*

Size: Emissions in stabilised state: CO*

Moisture content:* CO₂*

O₂*

Dust*

Person responsible for the inspection: Date:

Stamp: Customer's signature:

(Responsible person's signature)

* measured values

ANNUAL INSPECTIONS RECORDS

EN

Date	Date	Date	Date
stamp and signature	stamp and signature	stamp and signature	stamp and signature

Date	Date	Date	Date
stamp and signature	stamp and signature	stamp and signature	stamp and signature

Date	Date	Date	Date
stamp and signature	stamp and signature	stamp and signature	stamp and signature

Date	Date	Date	Date
stamp and signature	stamp and signature	stamp and signature	stamp and signature

Date	Date	Date	Date
stamp and signature	stamp and signature	stamp and signature	stamp and signature

RECORDS OF GUARANTEE PERIOD AND POST-GUARANTEE PERIOD REPAIRS

EN

Repair:

Repair:

Repair:

Repair:

.....
repair carried out by, date

Repair:

Repair:

Repair:

Repair:

.....
repair carried out by, date

Repair:

Repair:

Repair:

Repair:

.....
repair carried out by, date

Repair:

Repair:

Repair:

Repair:

.....
repair carried out by, date

