

DRAŽICE



**STORAGE
TANKS**



**Storage tanks are supplied
including insulation.**

ICONS | Legend

INLETS 

OUTLETS 



Solid fuel boiler



Biomass boiler



Fireplace insert



Electric heating
– dry ceramic unit TPK 210–12



Electric heating
– wet unit TJ ¼"



Heat pump



Photothermic solar system



Photovoltaic solar system



Floor heating



Radiator



Hot water



Cooling

Tolerance of all stated dimensions complies with ČSN ISO 2768-c
Z/T circuit socket = socket of heating sources and heating circuits
Note: * The value is derived by calculation



IT ALL BEGAN WITH A SIMPLE IDEA

to produce the most cost-efficient and trouble-free water heater – the best storage heater. Every year, we think we are close enough to our goal. And yet, every year we produce more sophisticated water heaters, storage tanks and heating elements, ...

Maximum user comfort, energy efficiency and environmental responsibility are the main driving forces in our daily work.

STORAGE TANKS

serve to accumulate excess heat from its source. The source may be a solid fuel boiler, heat pump, solar collectors, a fireplace insert etc. Some types of tanks allow combining and connecting multiple sources of heat.



STORAGE TANKS TYPES NAD AND NADS

(without DHW preparation)

serve only for storing heat in the heating system.



NADO AND NADOS STORAGE TANKS

(with DHW preparation)

also allow indirect water heating or water preheating for another water heater.

CONTENT

STORAGE TANKS /RESERVOIRS/ without DHW preparation	8	STORAGE TANK NAD v1
	10	STORAGE TANK NAD v2
	11	STORAGE TANK NAD v3
	12	STORAGE TANK NADS v3
	13	STORAGE TANK NAD v4
	14	STORAGE TANK NAD v15
STORAGE TANKS /RESERVOIRS/ with DHW preparation	20	STORAGE TANK NADO v1
	22	STORAGE TANK NADOS v1
	24	STORAGE TANK NADO v2
	26	STORAGE TANK NADOS v2
	28	STORAGE TANK NADO v6
	30	STORAGE TANK NADO v11
ACCESSORIES	34	HEAT INSULATION NEODUL LB PP
	35	IPS ProtectX
	36	ORIGINAL PARTS FROM DRAŽICE TITANIUM ANODE, BRASS THERMOWELL
	40	ACCESSORY TABLES
ANOTHER ASSORTMENT	44	PHOTOVOLTAIC
	45	WATER HEATERS
	46	AIR CONDITION - SPLIT AND MULTISPLIT





STORAGE TANKS

WITHOUT DHW PREPARATION

NAD v1 /types 50, 100 and 200/

STORAGE TANK

WITHOUT DHW PREPARATION



■ Types: 50, 100, 200

■ The tank is supplied with non-detachable insulation

■ Suitable as an equalization tank for heating systems with solid fuel boilers

■ Also suitable for cooling

■ The TJ ¼" heating unit can be mounted into the socket



Socket dimensions	NAD 50 v1	NAD 100 v1	NAD 200 v1
Socket 1	1" female thread		1" female thread
Socket 2	1 ½" female thread		½" female thread
Socket 3	½" female thread		1" male thread
Socket 4		-	1 ½" female thread

Technical parameters		NAD 50 v1	NAD 100 v1	NAD 200 v1
Order number		110580391	1108803102	1107803191
Heating water volume in tank	[l]	50	120	208
Weight including insulation (without water)	[kg]	25	41	80
Max. operating temperature / pressure in tank	[°C] / [bar]		90 / 3	
Insulation thickness (Polyurethane)	[mm]		42	
Heat conductivity of insulation (Polyurethane)	[W·m ⁻¹ ·K ⁻¹]		0,022	
Max. number × output of TJ ¼"	[pcs] × [kW]	1 × 3,3		1 × 6
Energy efficiency class (Polyurethane)			B	C
Standing loss (Polyurethane)	[W]	31	41	82

Tank dimensions		NAD 50 v1	NAD 100 v1	NAD 200 v1
Tank diameter	∅ d	440	500	500
Tank diameter with insulation	∅ D	524	584	584
Total tank height	L	561	803	1387
Tilting height	L _k	-	-	1470
Discharging connection	A	215	225	225
Z/T circuit socket	B	345	575	1125
Max. number × output of TJ ¼"	C	265	400	675
Sensor pocket socket	E	365	555	795
Spacing of user-type suspension	R	300-310, 350-372, 432-468		-

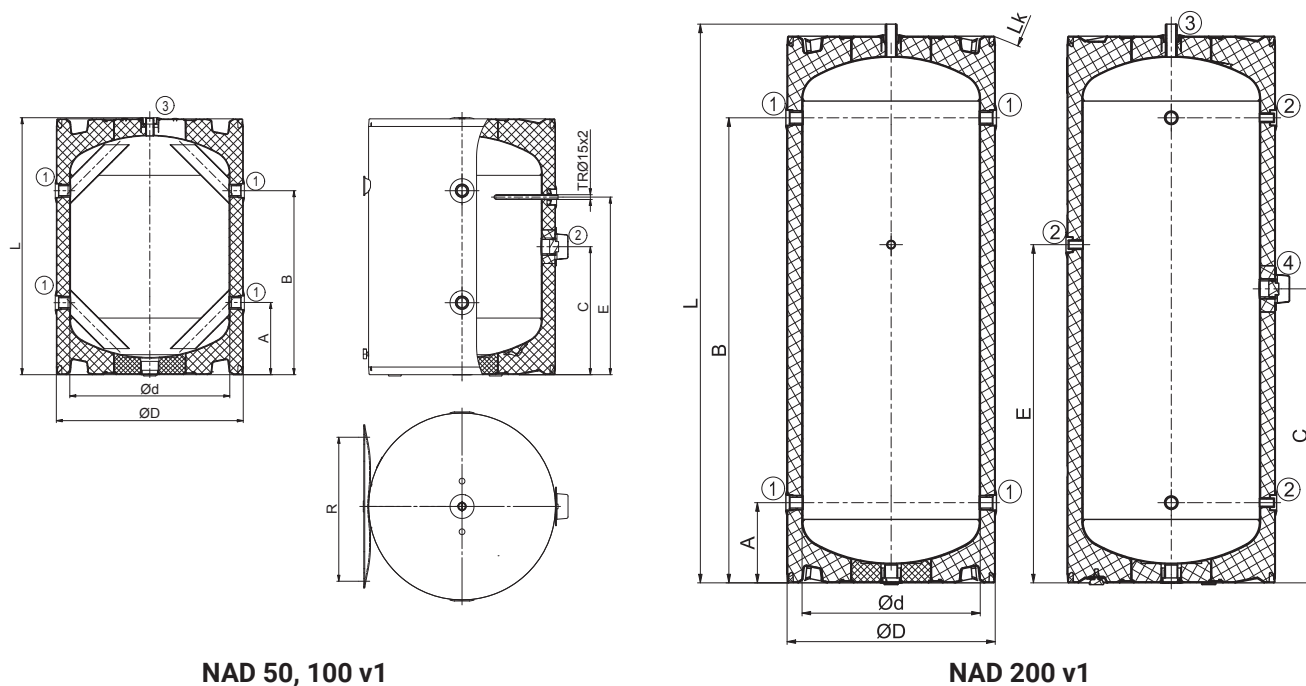

NAD 50, 100 v1

NAD 200 v1

NAD v1 /types 500–2000/

STORAGE TANK

WITHOUT DHW PREPARATION



- Types: 500, 750, 1000, 1500, 2000 l
- The tank is supplied including insulation**
- Suitable as an equalization tank for heating systems with solid fuel boilers
- The TPK 210-12 heating unit can be mounted into the flange
- We can supply 2 more custom made flanges for the tank
- The TJ ¼" heating unit can be mounted into the socket



Socket dimensions	NAD 500 v1	NAD 750 v1	NAD 1000 v1	NAD 1500 v1	NAD 2000 v1
Socket 1 – female thread			1 ¼"		
Socket 2 – female thread			½"		
Socket 3 – male thread			1"		
Socket 4 – female thread			1 ½"		

Technical parameters		NAD 500 v1	NAD 750 v1	NAD 1000 v1	NAD 1500 v1	NAD 2000 v1
Order number		1213803293	1216803293	1215803293	122180393	122280393
Heating water volume in tank	[l]	475	772	999	1507	2007
Weight including insulation (without water)	[kg]	96	122	141	204 (without insulation)	247 (without insulation)
Max. operating temperature / pressure in tank	[°C] / [bar]	90 / 3				
Insulation thickness (Neodul LB PP)	[mm]	80			100	120
Heat conductivity of insulation (Neodul LB PP)	[W·m ⁻¹ ·K ⁻¹]	0,032				
Order number of insulation (Neodul LB PP)		tank component	tank component	tank component	6231710	6231711
Max. number × output of TPK 210-12	[pcs] × [kW]	1 × 12				
Max. number × output of TJ ¼"	[pcs] × [kW]	1 × 9				
Max. number × output of TPJ 150-8	[pcs] × [kW]	1 × 12				1 × 15
Energy efficiency class (Neodul LB PP)		C				
Standing loss (Neodul LB PP)	[W]	83	122	135	165	185

Tank dimensions		NAD 500 v1	NAD 750 v1	NAD 1000 v1	NAD 1500 v1	NAD 2000 v1
Tank diameter	∅ d	600	750	850	1100	1100
Tank diameter with insulation	∅ D	760	910	1010	–	–
Total tank height	L	1970	2030	2040	1906	2436
Tilting height	L _k	1990	2050	2060	1925	2480
Discharging connection	A	100	100	100	135	135
Z/T circuit socket	B	270	282	297	350	350
Z/T circuit socket	C	958	970	985	910	1175
Z/T circuit socket	E	1644	1656	1671	1470	2000
Sensor pocket socket	F	505	517	532	600	600
Sensor pocket socket	G	1554	1566	1581	1380	1910
Max. number × output of TJ ¼"	I	937	950	965	895	1160
Flange socket	J	353	366	381	450	450

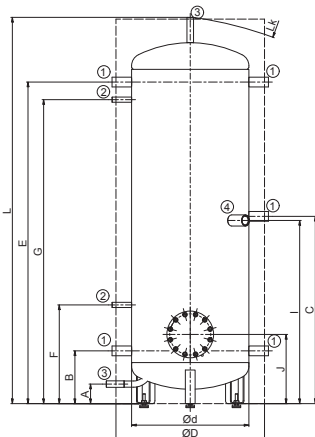

NAD 500, 750, 1000 v1

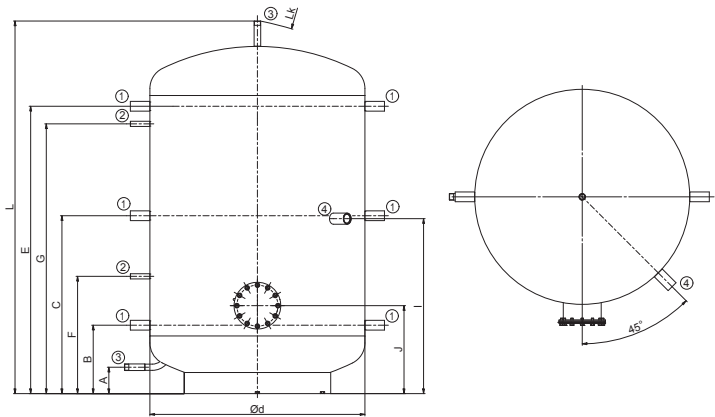

NAD 1500, 2000 v1

NAD v2

STORAGE TANK

WITHOUT DHW PREPARATION



- Types: 500, 750, 1000, 1500, 2000 l
- The tank is supplied including insulation**
- Suitable as an equalization tank for heating systems with solid fuel boilers
- The TJ ¼" heating unit can be mounted into the socket



Socket dimensions	NAD 500 v2	NAD 750 v2	NAD 1000 v2	NAD 1500 v2	NAD 2000 v2
Socket 1 – female thread			1 ¼"		
Socket 2 – female thread			½"		
Socket 3 – male thread			1"		
Socket 4 – female thread			1 ½"		

Technical parameters		NAD 500 v2	NAD 750 v2	NAD 1000 v2	NAD 1500 v2	NAD 2000 v2
Order number		1213803294	1216803294	1215803294	122180394	122280394
Heating water volume in tank	[l]	475	772	999	1507	2007
Weight including insulation (without water)	[kg]	87	114	129	192 (without insulation)	235 (without insulation)
Max. operating temperature / pressure in tank	[°C] / [bar]	90 / 3				
Insulation thickness (Neodul LB PP)	[mm]	80			100	120
Heat conductivity of insulation (Neodul LB PP)	[W·m ⁻¹ ·K ⁻¹]	0,032				
Order number of insulation (Neodul LB PP)		tank component	tank component	tank component	6231712	6231713
Max. number × output of TJ ¼"	[pcs] × [kW]	1 × 9				
Energy efficiency class (Neodul LB PP)		C				
Standing loss (Neodul LB PP)	[W]	83	122	135	165	185

Tank dimensions		NAD 500 v2	NAD 750 v2	NAD 1000 v2	NAD 1500 v2	NAD 2000 v2
Tank diameter	∅ d	600	750	850	1100	1100
Tank diameter with insulation	∅ D	760	910	1010	–	–
Total tank height	L	1970	2030	2040	1906	2436
Tilting height	L _k	1990	2050	2060	1925	2480
Discharging connection	A	100	100	100	135	135
Z/T circuit socket	B	270	282	297	365	365
Z/T circuit socket	C	1644	1656	1671	1470	2000
Sensor pocket socket	E	505	517	532	600	600
Sensor pocket socket	F	1554	1566	1581	1380	1910
TJ ¼" heating unit socket	G	375	386	402	470	470

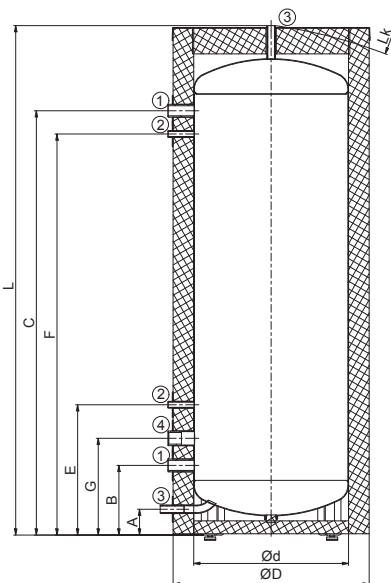

NAD 500, 750, 1000 v2

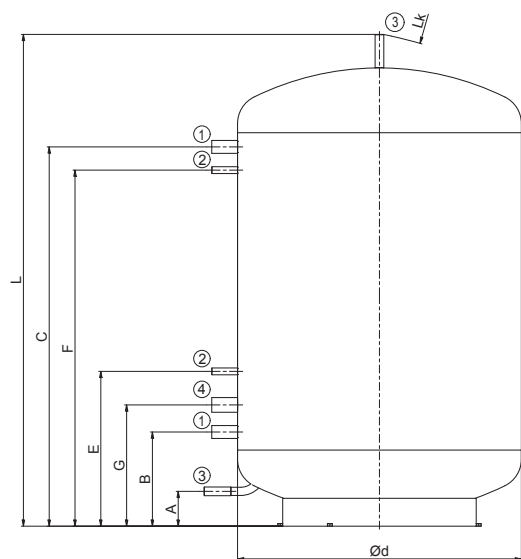

NAD 1500, 2000 v2

NAD v3

STORAGE TANK

WITHOUT DHW PREPARATION



- Typy: 300, 500, 750, 1000 l
- The tank is supplied including insulation, NAD 300 v3 tank is supplied with permanent insulation
- Suitable as an equalization tank for heating systems with solid fuel boilers
- The TPK 210-12 heating unit can be mounted into the flange
- The TJ 3/4" heating unit can be mounted into the socket



Socket dimensions	NAD 300 v3	NAD 500 v3	NAD 750 v3	NAD 1000 v3
Socket 1 - female thread		1 1/2"		
Socket 2 - female thread		1/2"		
Socket 3 - male thread		1"		

Technical parameters		NAD 300 v3	NAD 500 v3	NAD 750 v3	NAD 1000 v3
Order number		121080301	1213803287	1216803287	1215803287
Heating water volume in tank	[l]	320	475	772	999
Weight including insulation (without water)	[kg]	70	98	123	141
Max. operating temperature / pressure in tank	[°C] / [bar]	90 / 3			
Insulation thickness (Neodul LB PP)	[mm]	PUR 50		80	
Heat conductivity of insulation (Neodul LB PP)	[W·m ⁻¹ ·K ⁻¹]	0,032			
Max. number × output of TPK 210-12	[pcs] × [kW]	-		1 × 12	
Max. number × output of TJ 3/4"	[pcs] × [kW]	1 × 3,3+3×9	2 × 3,3+4×9	2 × 3,75+4×9	2×6+4×9
Max. number × output of TPJ 150-8	[pcs] × [kW]	-		1 × 12	1 × 15
Energy efficiency class (Neodul LB PP)		C			
Standing loss (Neodul LB PP)	[W]	80	83	122	135

Tank dimensions		NAD 300 v3	NAD 500 v3	NAD 750 v3	NAD 1000 v3
Tank diameter	∅ d	550	600	750	850
Tank diameter with insulation	∅ D	650	760	910	1010
Total tank height	L	1575	1970	2030	2040
Tilting height	L _k	1660	1990	2050	2060
Z/T circuit and sensor pocket socket	A	245	270	282	297
Z/T circuit and sensor pocket socket	B	760	728	739	755
Z/T circuit and sensor pocket socket	C	1275	1186	1197	1213
Z/T circuit and sensor pocket socket	E	-	1644	1656	1671
Flange socket	F	-	353	366	381

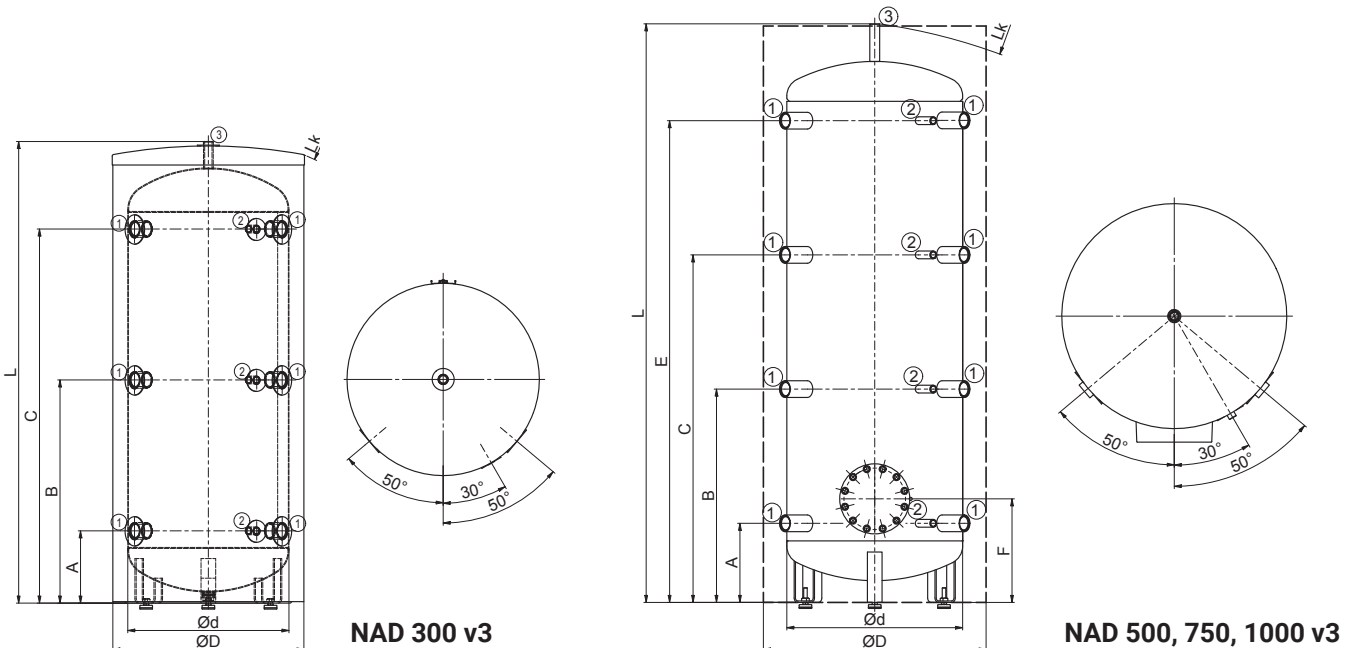

NAD 300 v3

NAD 500, 750, 1000 v3

NADS v3

STORAGE TANK

WITHOUT DHW PREPARATION



- Types: 800 l
- The tank is supplied including insulation**
- Suitable as an equalization tank for heating systems with solid fuel boilers
- The TJ ¼" heating unit can be mounted into the socket
- The tank is dimensioned for passage through the 80 cm door



NADS 800 v3

Socket dimensions	NADS 800 v3
Socket 1 – female thread	1 ½"
Socket 2 – female thread	½"
Socket 3 – male thread	1"
Socket 4 – female thread	1"

Technical parameters		NADS 800 v3
Order number		1218803287
Heating water volume in tank	[l]	775
Weight including insulation (without water)	[kg]	114
Max. operating temperature / pressure in tank	[°C] / [bar]	90 / 3
Insulation thickness (Neodul LB PP)	[mm]	80
Heat conductivity of insulation (Neodul LB PP)	[W·m ⁻¹ ·K ⁻¹]	0,032
Max. number × output of TJ ¼"	[pcs] × [kW]	1 × 3,75+3×9
Energy efficiency class (Neodul LB PP)		C
Standing loss (Neodul LB PP)	[W]	116

Tank dimensions		NADS 800 v3
Tank diameter	∅ d	790
Tank diameter with insulation	∅ D	950
Total tank height	L	1880
Tilting height	L _k	1900
Discharging connection	A	157
Z/T circuit socket	B	275
Z/T circuit socket	C	870
Z/T circuit socket	E	1470
Sensor pocket	F	365
Sensor pocket	G	1380

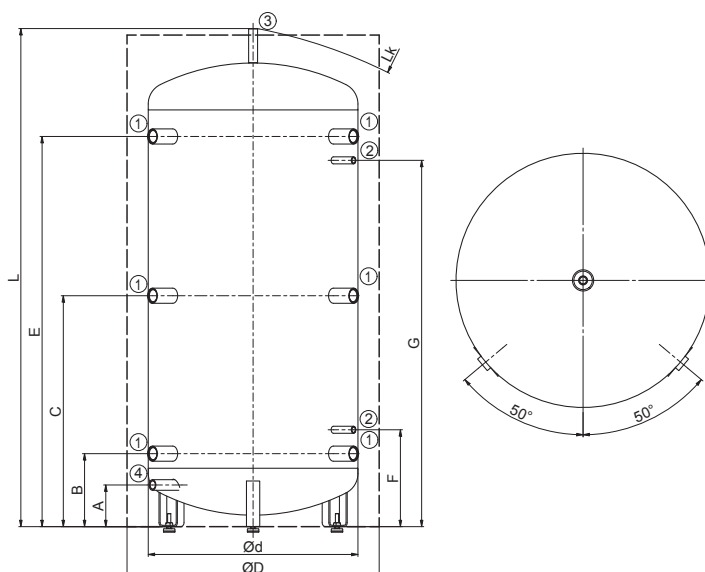

NAD v4

STORAGE TANK

WITHOUT DHW PREPARATION



- Types: 500, 750, 1000 l
- The tank is supplied including insulation**
- Suitable as an equalization tank for heating systems with solid fuel boilers
- The TJ ¼" heating unit can be mounted into the socket
- The TPK 210-12 heating unit can be mounted into the flange



NAD 500 v4

Socket dimensions	NAD 500 v4	NAD 750 v4	NAD 1000 v4
Socket 1 – female thread		1 ¼"	
Socket 2 – female thread		½"	
Socket 3 – male thread		1"	
Socket 4 – female thread		1 ½"	

Technical parameters		NAD 500 v4	NAD 750 v4	NAD 1000 v4
Order number		1213803295	1216803295	1215803295
Heating water volume in tank	[l]	475	772	999
Weight including insulation (without water)	[kg]	121	148	164
Max. operating temperature / pressure in tank	[°C] / [bar]	90 / 3		
Heat transfer surface of exchanger	[m²]	1,4		
Exchanger volume	[l]	10,5		
Max. operating temperature / pressure in exchanger	[°C] / [bar]	110 / 10		
Insulation thickness (Neodul LB PP)	[mm]	80		
Heat conductivity of insulation (Neodul LB PP)	[W·m ⁻¹ ·K ⁻¹]	0,032		
Max. number × output of TPK 210-12	[pcs] × [kW]	1 × 6	1 × 12	
Max. number × output of TJ ¼"	[pcs] × [kW]	1 × 9		
Max. number × output of TPJ 150-8	[pcs] × [kW]	1 × 9	1 × 12	1 × 15
Energy efficiency class (Neodul LB PP)		C		
Standing loss (Neodul LB PP)	[W]	80	119	133

Tank dimensions		NAD 500 v4	NAD 750 v4	NAD 1000 v4
Tank diameter	∅ d	600	750	850
Tank diameter with insulation	∅ D	760	910	1010
Total tank height	L	1970	2030	2040
Tilting height	L _k	1990	2050	2060
Discharging connection	A	100	100	100
Z/T circuit socket	B	270	282	297
Z/T circuit socket	C	958	970	985
Z/T circuit socket	E	1644	1656	1671
Sensor pocket socket	F	505	517	532
Sensor pocket socket	G	1554	1566	1581
Max. number × output of TJ ¼"	I	937	950	965
Heat exchanger socket	J	360	344	387
Heat exchanger socket	K	888	872	915
Flange socket	M	353	366	381

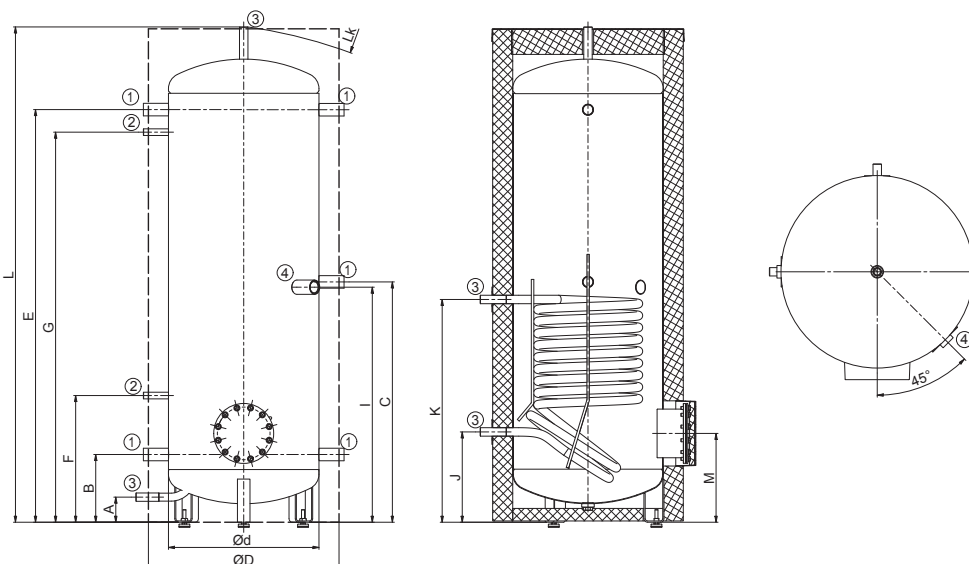

NAD v15

STORAGE TANK

WITHOUT DHW PREPARATION



NEW

- Suitable for installation with heat pumps for cooling
- Available capacities from 200 to 2000 litres
- Models 200, 300 and 500 are supplied with non-removable insulation
- For larger models (750–2000), three insulation variants are available: NEODUL LB PP for heating, CELLA COOL for cooling, and a combined version
- For cooling applications, CELLA COOL insulation is required for models 750–2000
- TJ heating units can be installed in the sleeves

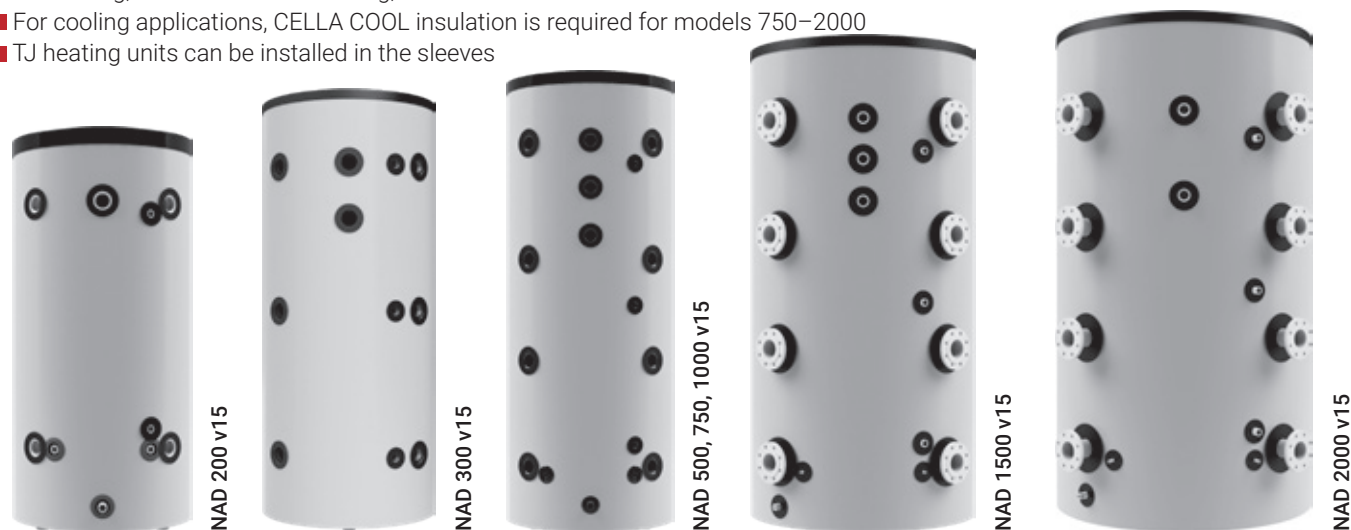

Socket dimensions	NAD 200 v15	NAD 300 v15	NAD 500 v15	NAD 750 v15	NAD 1000 v15	NAD 1500 v15	NAD 2000 v15
Socket 1 – female thread	1 ½"	1 ½"	1 ½"	1 ½"	1 ½"	1 ½"	1 ½"
Socket 2 – female thread	½"	½"	½"	½"	½"	½"	½"
Socket 3 – female thread	–	–	2"	2"	2"	–	2"
Socket 4 – male thread	–	1"	1"	1"	1"	1"	1"
Socket 5 – male thread	¾"	–	–	–	–	–	–
Socket 6 – female thread	1"	–	–	–	–	–	–
Socket 7	–	–	–	pocket 15x2	pocket 15x2	pocket 15x2	pocket 15x2
Socket 8	–	–	–	–	–	PN16, DN80/88,9	PN16, DN80/88,9

Technical parameters		NAD 200 v15	NAD 300 v15	NAD 500 v15	NAD 750 v15	NAD 1000 v15	NAD 1500 v15	NAD 2000 v15
Order number		1107803204	1210803204	1213803204	1216803204	1215803204	1221803204	1222803204
Heating water volume in tank	[l]	200	320	475	772	999	1 490	2 007
Weight including insulation (without water)	[kg]	45	70	98	123	141	245	290
Max. operating temperature / pressure in tank	[°C] / [bar]	90 / 3						
Insulation thickness (Neodul LB PP)	[mm]	PUR 50	PUR 50	PUR 70	80	80	100	100
Heat conductivity of insulation (Neodul LB PP)	[W·m ⁻¹ ·K ⁻¹]	0,021	0,021	0,021	0,032	0,032	0,032	0,032
Order number of insulation (Neodul LB PP)			–		6232166	6232167	6232168	6232165
Objednací číslo izolace CELLA COOL			–		6231834	6231836	6231837	6231835
Order number of insulation Neodul LB PP (CELLA COOL)			–		6231736	6231737	6231738	6231739
Max. number × output of TJ ¾"	[pcs] × [kW]	1 × 6	2 × 6	3 × 9	3 × 9	3 × 9	3 × 9	2 × 9
Energy efficiency class (Neodul LB PP)		B	C	B			–	
Standing loss (Neodul LB PP)	[W]	53	80	68			–	

Tank dimensions		NAD 200 v15	NAD 300 v15	NAD 500 v15	NAD 750 v15	NAD 1000 v15	NAD 1500 v15	NAD 2000 v15
Tank diameter	∅ d	500	550	600	750	850	950	1100
Tank diameter with insulation	∅ D	600	650	740	–	–	–	–
Total tank height	L	1285	1575	2050	2000	2013	2362	2452
Tilting height	L _k	1385	1660	1538	2030	2050	2388	2486
Discharging connection	A	85	–	120	100	100	97	134
Z/T circuit socket Heat exchanger socket TJ ¾"	B	255	247	265	282	287	315	363
Z/T circuit socket	C	1025	762	712	729	745	865	903
Z/T circuit socket Heat exchanger socket TJ ¾"	E	–	1277	1140	1157	1203	1417	1443
Z/T circuit socket Heat exchanger socket TJ ¾"	F	–	–	1630	1647	1661	1967	1983
Sensor pocket	G	320	–	238	255	257	277	323
Sensor pocket	H	990	–	361	378	387	415	461
Sensor pocket	I	–	–	946	963	970	1090	1136
Sensor pocket socket	J	–	–	1538	1555	1569	1817	1863
Heat exchanger socket TJ ¾"	K	–	1082	1235	1252	1245	1572	1583
Heat exchanger socket TJ ¾"	M	–	–	1435	1452	1450	1772	–

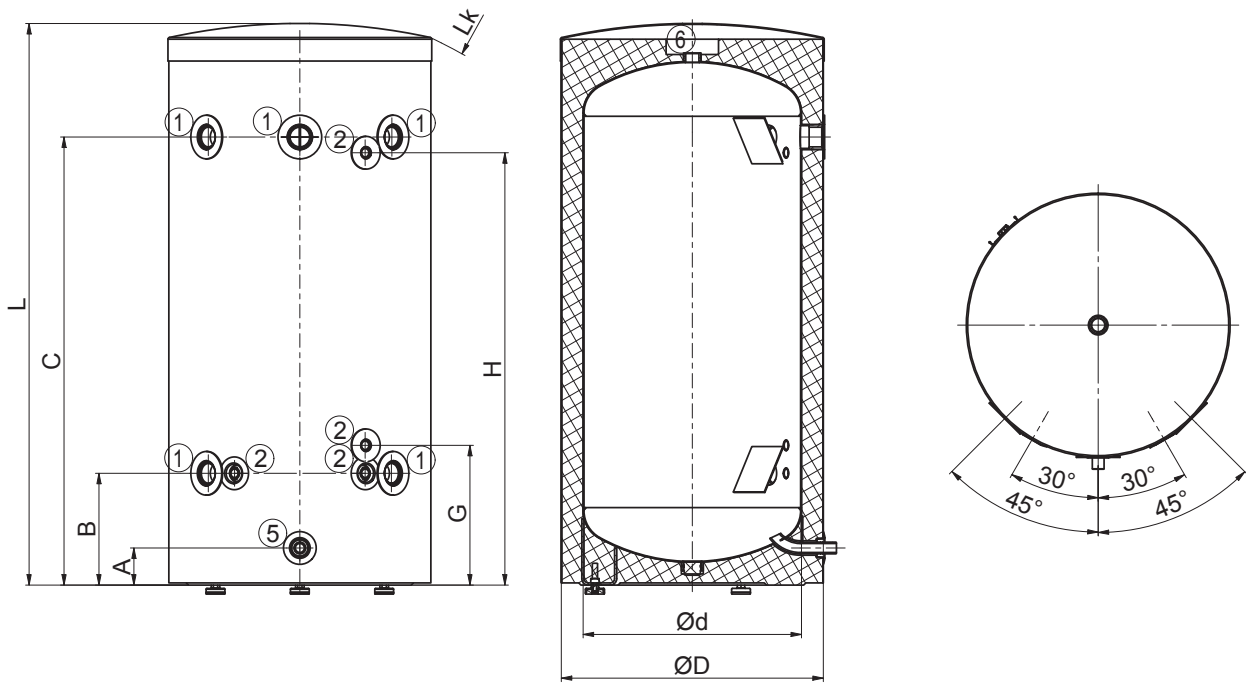

NAD 200 v15

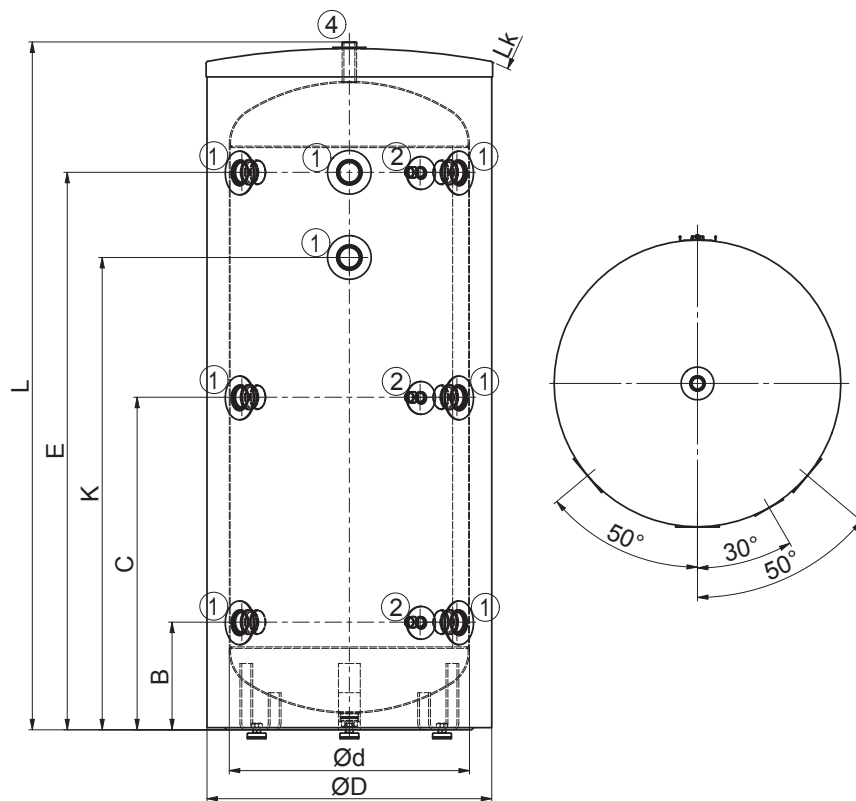

NAD 300 v15

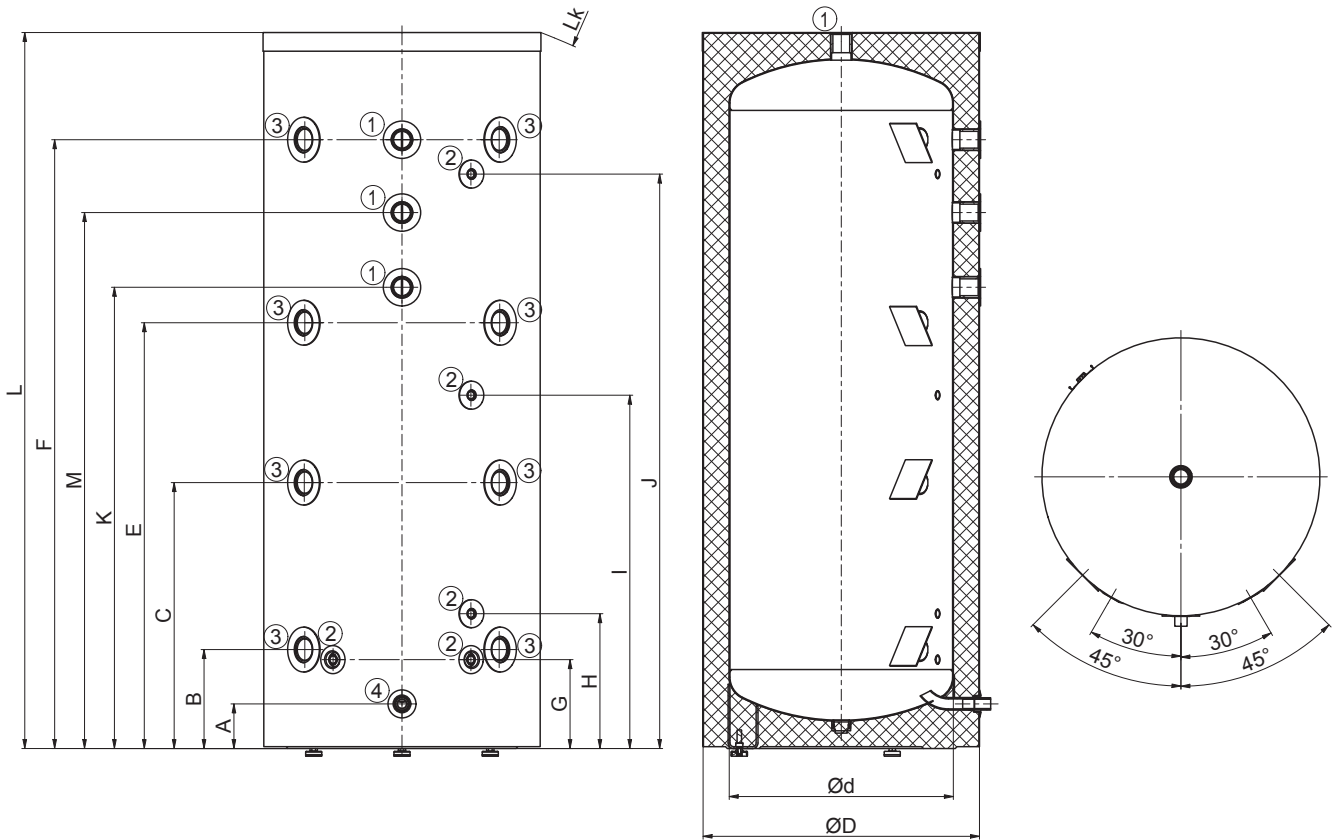

NAD 500 v15 | NAD 750 v15

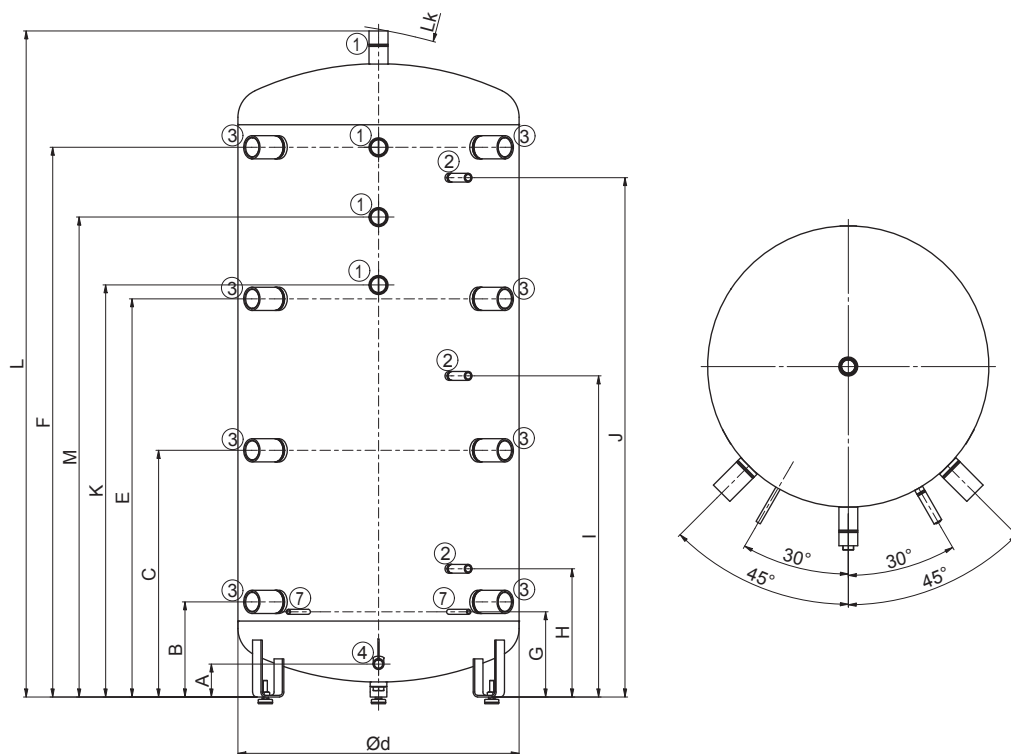

NAD 1000 v15

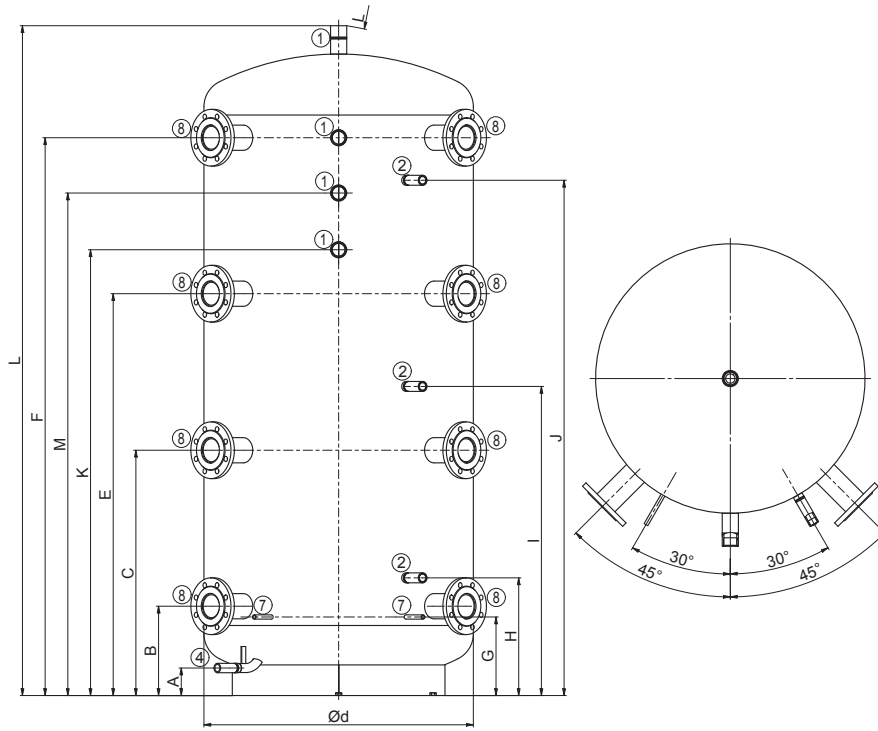

NAD 1500 v15

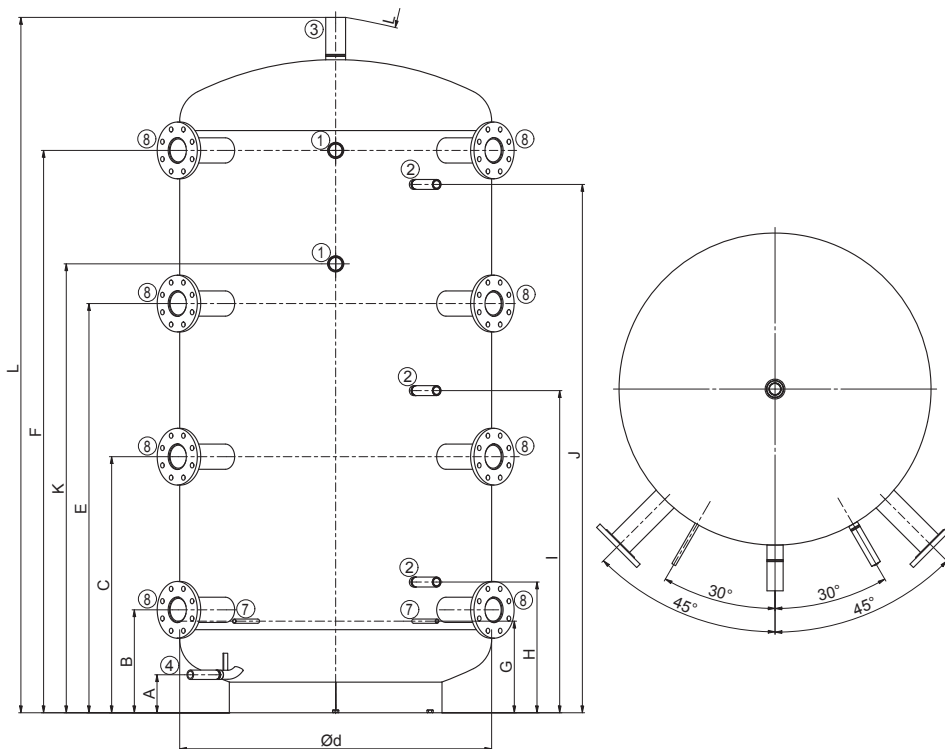

NAD 2000 v15





STORAGE TANKS

WITH DHW PREPARATION

NADO v1

STORAGE TANK

WITH DHW PREPARATION



- Types: 500, 750, 1000 l
- Inner HW storage tank in volumes of 140 and 200 l
- **The tank is supplied including insulation**
- Suitable as a storage tank for heating systems with solid fuel boilers
- Suitable as a storage tank for heating systems with solid fuel boilers
- The TJ ¼" heating unit can be mounted into the socket for 140 l version

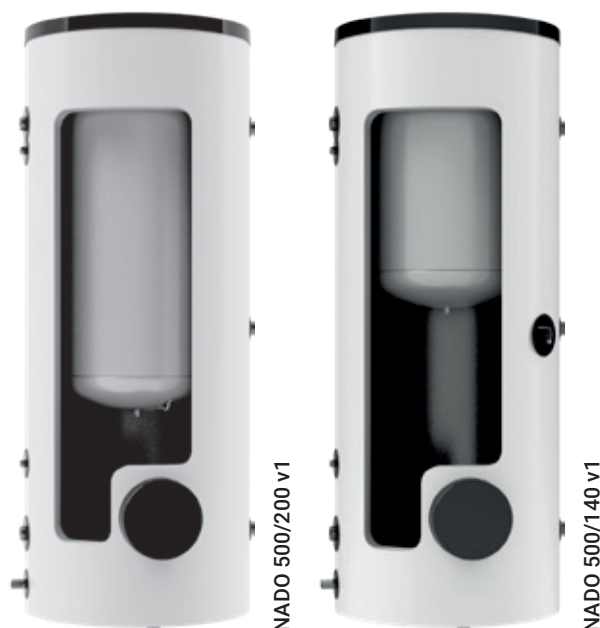

Socket dimensions	NADO 500 v1	NADO 750 v1	NADO 1000 v1
Socket 1 – female thread		1 ¼"	
Socket 2 – female thread		½"	
Socket 3 – male thread		1"	
Socket 4 – male thread		¾"	
Socket 5 – female thread		1 ½"	

Technical parameters		NADO 500/140 v1	NADO 750/140 v1	NADO 1000/140 v1	NADO 500/200 v1	NADO 750/200 v1	NADO 1000/200 v1
Order number		1213803215	1216803215	1215803215	1213803297	1216803297	1215803297
Heating water volume in tank	[l]	475	772	999	475	772	999
Volume of storage tank for HW heating	[l]		140			210	
Weight including insulation (without water)	[kg]	124	150	167	138	164	181
Max. operating temperature / pressure in tank	[°C] / [bar]	90 / 3					
Max. operating temp. / pressure in HW storage tank	[°C] / [bar]	90 / 6					
Heat transfer surface of HW storage tank	[m²]	1,43			1,95		
Capacity of hot water 40 °C at storage tank temp. 53 °C and inlet water 15 °C / HW flow rate*	[l] / [l·min ⁻¹]	260/5	490/5	750/5	260/ 10	490/ 10	750/ 10
Capacity of hot water 40 °C at storage tank temp 80 °C and inlet water 15 °C / HW flow rate*	[l] / [l·min ⁻¹]	650/5	1170/5	1450/5	650/ 10	1170/ 10	1450/ 10
Insulation thickness (Neodul LB PP)	[mm]	80					
Heat conductivity of insulation (Neodul LB PP)	[W·m ⁻¹ ·K ⁻¹]	0,032					
Max. number × output of TPK 210-12	[pcs] × [kW]	1 × 12					
Max. number × output of TJ ¼"	[pcs] × [kW]	1 × 9			-		
Max. number × output of TPJ 150-8	[pcs] × [kW]	1 × 12		1 × 15			
Energy efficiency class (Neodul LB PP)		B	C		B	C	
Standing loss (Neodul LB PP)	[W]	80	117	130	80	117	130

Tank dimensions		NADO 500/140 v1	NADO 750/140 v1	NADO 1000/140 v1	NADO 500/200 v1	NADO 750/200 v1	NADO 1000/200 v1
Tank diameter	∅ d	600	750	850	600	750	850
Tank diameter with insulation	∅ D	760	910	1010	760	910	1010
Total tank height	L	1970	2030	2040	1970	2030	2040
Tilting height	L _k	1990	2050	2060	1990	2050	2060
Discharging connection	A	100	100	100	100	100	100
Z/T circuit socket	B	270	282	297	270	282	297
Z/T circuit socket	C	958	970	985	958	970	985
Z/T circuit socket	E	1644	1656	1671	1644	1656	1671
Sensor pocket socket	F	505	517	532	505	517	532
Sensor pocket socket	G	1554	1566	1581	1554	1566	1581
Flange socket	I	353	366	381	353	366	381
TJ ¼" heating unit socket	J	937	950	965	-	-	-

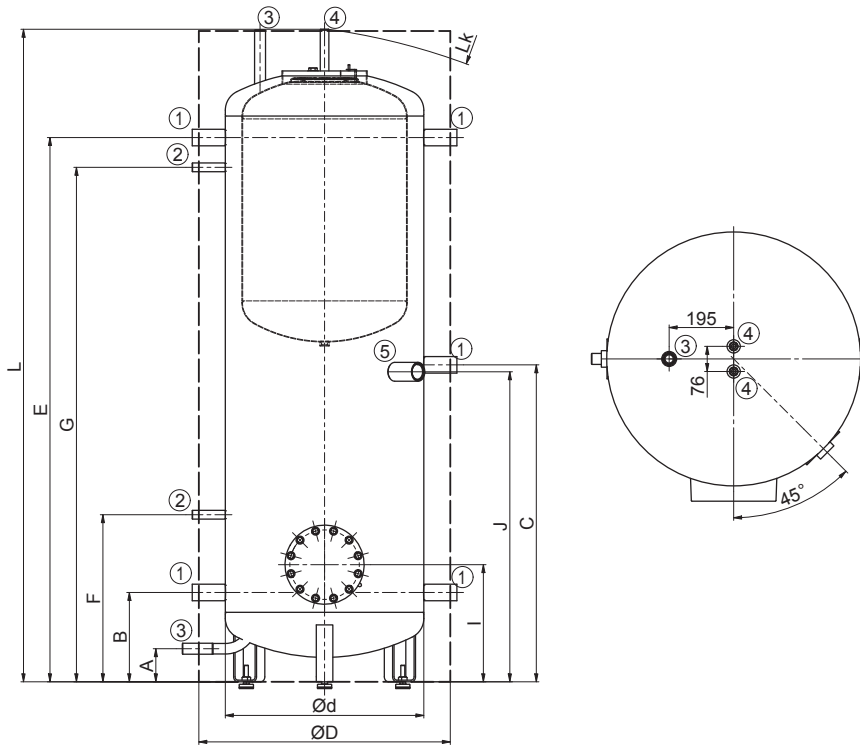

NADO 500/140 v1

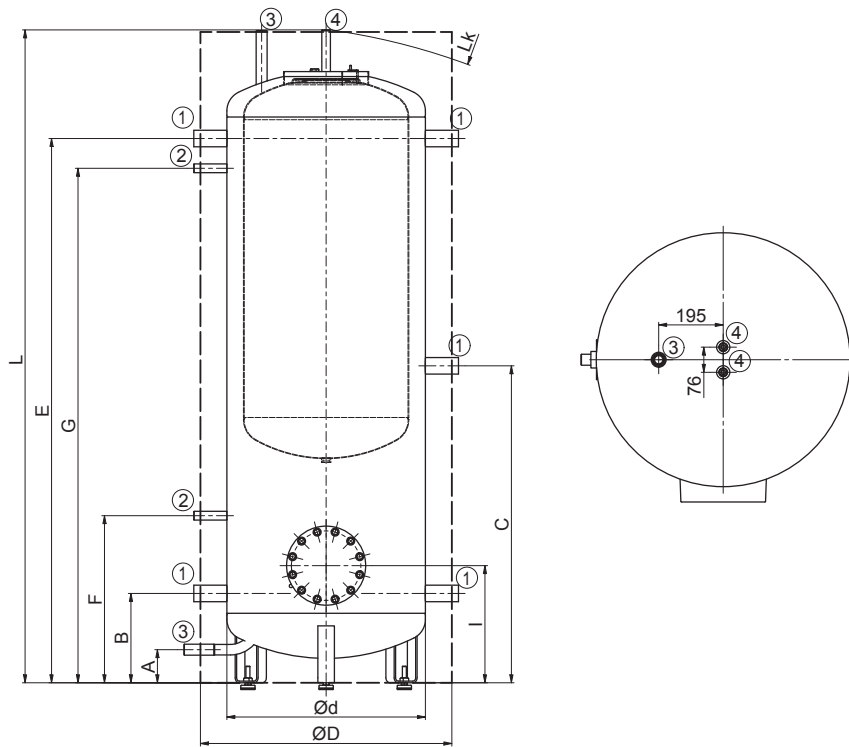

NADO 500/200 v1

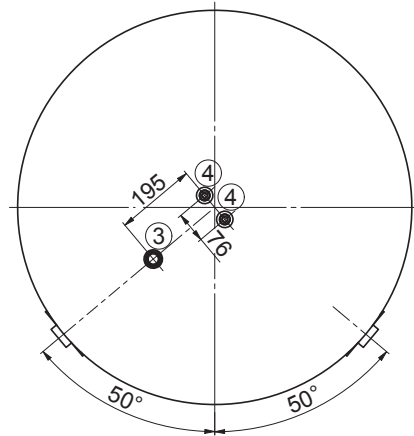
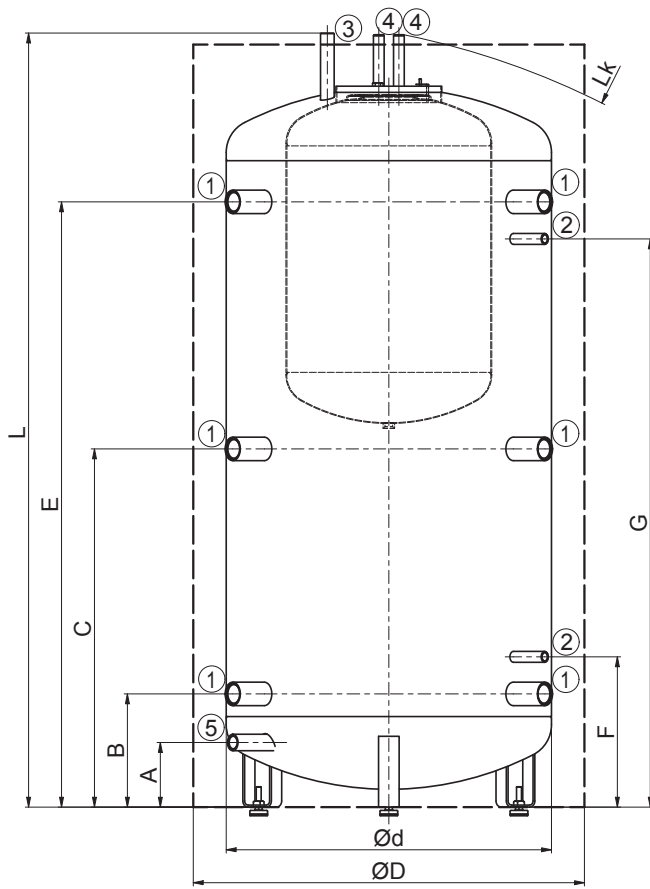

NADOS v1

NADO v2

STORAGE TANK

WITH DHW PREPARATION



- Types: 500, 750, 1000 l
- Inner HW storage tank in a volume of 140 l
- **The tank is supplied including insulation**
- Suitable as an storage tank for heating systems with solid fuel boilers and solar systems
- The TPK 210-12 heating unit can be mounted into the flange
- The TJ ¼" heating unit can be mounted for tanks with inner storage tank in a volume of 140 l

Socket dimensions	NADO 500/140 v2	NADO 750/140 v2	NADO 1000/140 v2
Socket 1 – female thread		1 ¼"	
Socket 2 – female thread		½"	
Socket 3 – male thread		1"	
Socket 4 – male thread		¾"	
Socket 5 – female thread		1 ½"	



NADO 500/140 v2

Technical parameters		NADO 500/140 v2	NADO 750/140 v2	NADO 1000/140 v2
Order number		1213803291	1216803291	1215803291
Heating water volume in tank	[l]	475	772	999
Volume of storage tank for HW heating	[l]		140	
Weight including insulation (without water)	[kg]	154	181	195
Max. operating temperature / pressure in tank	[°C] / [bar]		90 / 3	
Max. operating temperature / pressure in HW storage tank	[°C] / [bar]		90 / 6	
Heat transfer surface of HW storage tank	[m²]		1,43	
Max. operating temperature / pressure in exchanger	[°C] / [bar]		110 / 10	
Heat transfer surface of exchanger	[m²]		1,4	
Exchanger volume flow rate	[m³·h⁻¹]		0,3	
Exchanger volume	[l]		10,5	
Capacity of hot water 40 °C at storage tank temperature 53 °C and inlet water 15 °C / HW flow rate*	[l] / [l·min⁻¹]	260/5	490/5	750/5
Capacity of hot water 40 °C at storage tank temperature 80 °C and inlet water 15 °C / HW flow rate*	[l] / [l·min⁻¹]	650/5	1170/5	1450/5
Insulation thickness (Neodul LB PP)	[mm]		80	
Heat conductivity of insulation (Neodul LB PP)	[W·m⁻¹·K⁻¹]		0,032	
Max. number × output of TPK 210-12	[pcs] × [kW]	1 × 6		1 × 12
Max. number × output of TJ ¼"	[pcs] × [kW]		1 × 9	
Max. number × output of TPJ 150-8	[pcs] × [kW]			
Energy efficiency class (Neodul LB PP)		1 × 9	1 × 12	1 × 15
Standing loss (Neodul LB PP)	[W]	79	116	128

Tank dimensions		NADO 500/140 v2	NADO 750/140 v2	NADO 1000/140 v2
Tank diameter	∅ d	600	750	850
Tank diameter with insulation	∅ D	760	910	1010
Total tank height	L	1970	2030	2040
Tilting height	L _k	1990	2050	2060
Discharging connection	A	100	100	100
Z/T circuit socket	B	270	282	297
Z/T circuit socket	C	958	970	985
Z/T circuit socket	E	1644	1656	1671
Sensor pocket socket	F	505	517	532
Sensor pocket socket	G	1554	1566	1581
Max. number × output of TJ ¼"	I	937	950	965
Heat exchanger socket	J	360	344	387
Heat exchanger socket	K	888	872	915
Flange socket	M	353	366	381

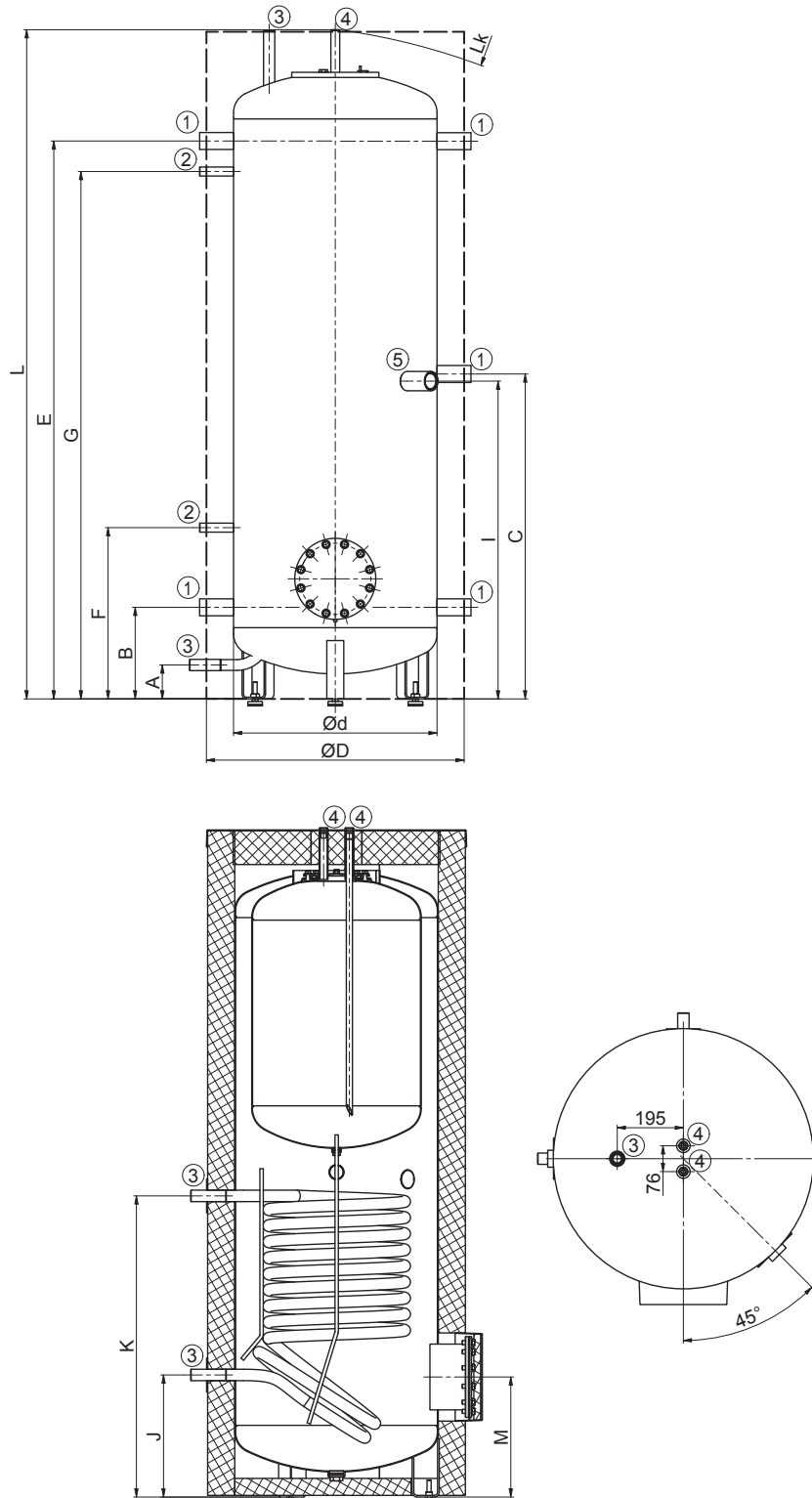

NADO 500/140 v2

NADOS v2

STORAGE TANK

WITH DHW PREPARATION



- Types: 800 l
- Inner HW storage tank in a volume of 140 l
- **The tank is supplied including insulation**
- Suitable as an equalization tank for heating systems with solid fuel boilers
- The TJ ¼" heating unit can be mounted into the socket
- The tank is dimensioned for passage through the 80 cm door



NADOS 800/140 v2

Socket dimensions	NADOS 800/140 v2
Socket 1 – female thread	1 ½"
Socket 2 – female thread	½"
Socket 3 – male thread	1"
Socket 4 – male thread	¾"
Socket 5 – female thread	1"

Technical parameters		NADOS 800/140 v2
Order number		1218803291
Heating water volume in tank	[l]	775
Volume of storage tank for HW heating	[l]	140
Weight including insulation (without water)	[kg]	169
Max. operating temperature / pressure in tank	[°C] / [bar]	90 / 3
Max. operating temperature / pressure in HW storage tank	[°C] / [bar]	90 / 6
Heat transfer surface of HW storage tank	[m²]	1,43
Max. operating temperature / pressure in exchanger	[°C] / [bar]	110 / 10
Heat transfer surface of exchanger	[m²]	1,5
Exchanger volume flow rate	[m³·h ⁻¹]	0,3
Exchanger volume	[l]	10,5
Capacity of hot water 40 °C at storage tank temperature 53 °C and inlet water 15 °C / HW flow rate*	[l] / [l·min ⁻¹]	495/5
Capacity of hot water 40 °C at storage tank temperature 80 °C and inlet water 15 °C / HW flow rate*	[l] / [l·min ⁻¹]	1175 / 5
Insulation thickness (Neodul LB PP)	[mm]	80
Heat conductivity of insulation (Neodul LB PP)	[W·m ⁻¹ ·K ⁻¹]	0,032
Max. number x output of TJ ¼"	[pcs] x [kW]	1 x 3,75+1x9
Energy efficiency class (Neodul LB PP)		C
Standing loss (Neodul LB PP)	[W]	116

Tank dimensions		NADOS 800/140 v2
Tank diameter	∅ d	790
Tank diameter with insulation	∅ D	950
Total tank height	L	1880
Tilting height	L _k	1900
Discharging connection	A	157
Z/T circuit socket	B	275
Z/T circuit socket	C	870
Z/T circuit socket	E	1470
Sensor pocket	F	365
Sensor pocket	G	1380
Heat exchanger socket	J	275
Heat exchanger socket	K	803

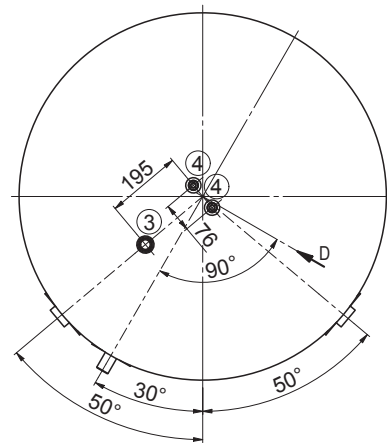
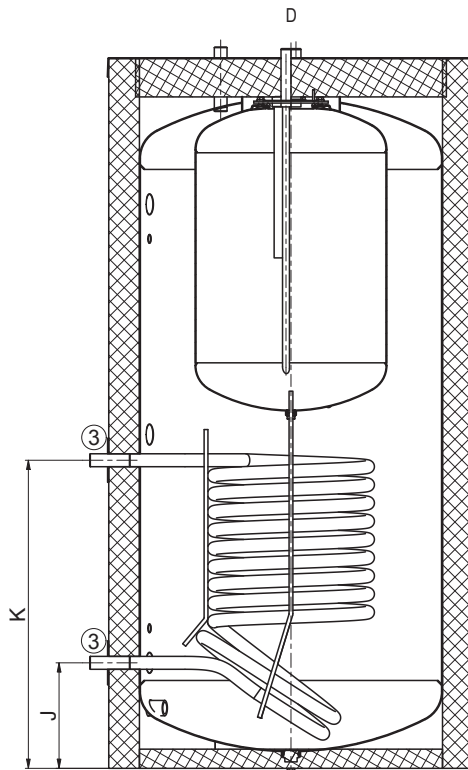
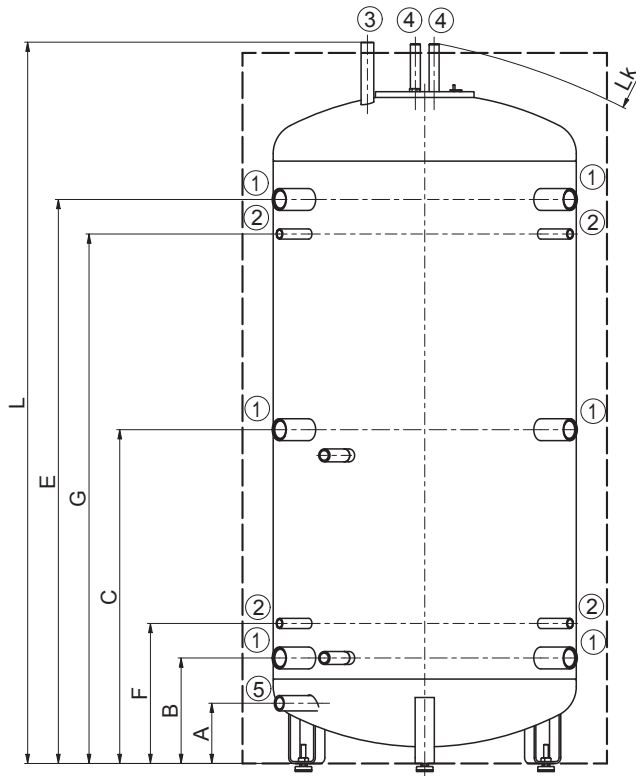

NADOS 800/140 v2

NADO v6

STORAGE TANK

WITH DHW PREPARATION



- Types: 300, 500, 750, 1000 l
- Heating by HW flow in a stainless steel exchanger with an above-average heat transfer surface
- **The tank is supplied including insulation**
- Various heat sources can be connected such as biomass, coal, gas and electric boilers, heat pumps and solar collectors
- The TJ ¼" electric cartridges can be mounted into sockets no. 4

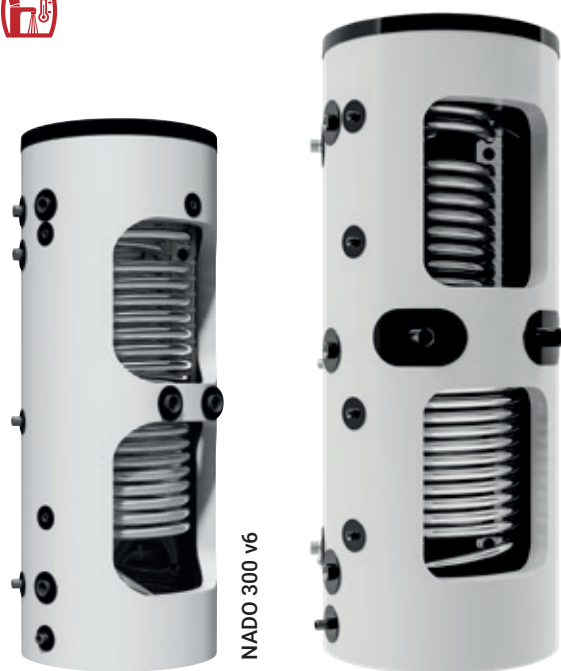

Socket dimensions	NADO 300/20 v6	NADO 500/25 v6	NADO 750/35 v6	NADO 1000/45 v6
Socket 1 – female thread			1 ¼"	
Socket 2 – male thread			1"	
Socket 3 – female thread			½"	
Socket 4 – female thread			1 ½"	
Socket 5 – male thread			1 ¼"	

Technical parameters		NADO 300/20 v6	NADO 500/25 v6	NADO 750/35 v6	NADO 1000/45 v6
Order number		1210803298	1213803250	1216803250	1215803250
Heating water volume in tank	[l]	358	475	772	999
Exchanger volume for HW heating	[l]	20	23	32	37
Weight including insulation (without water)	[kg]	106	145	178	212
Max. operating temperature / pressure in tank	[°C] / [bar]	90 / 3			
Max. operating temperature / pressure in exchanger HW	[°C] / [bar]	90 / 6			
Max. operating temperature / pressure in heat exchanger	[°C] / [bar]	110 / 10			
Heat transfer surface of exchanger TV	[m²]	4,5	6,25	8,5	10
HW exchanger volume flow rate	[m³·h⁻¹]	0,6			
Heat transfer surface of heat exchanger (top / bottom)	[m²]	- / 1,6	- / 2,2	- / 2,2	- / 3,3
Heat exchanger volume (top / bottom)	[l]	- / 12	- / 18	- / 18	- / 25
Capacity of hot water 40 °C at storage tank temperature 53 °C and inlet water 15 °C / HW flow rate*	[l] / [l·min⁻¹]	210/ 10	260/ 10	490/ 10	750/ 10
Capacity of hot water 40 °C at storage tank temperature 80 °C and inlet water 15 °C / HW flow rate*	[l] / [l·min⁻¹]	520/ 10	650/ 10	1170/ 10	1450/ 10
Insulation thickness (Neodul LB PP)	[mm]	60	80		
Heat conductivity of insulation (Neodul LB PP)	[W·m⁻¹·K⁻¹]	0,032			
Max. num. × out. of TJ ¼" h. unit with extended cooling section	[pcs] × [kW]	2 × 4,5	2 × 6		
Energy efficiency class (Neodul LB PP)		C			
Standing loss (Neodul LB PP)	[W]	97	91	114	148

Tank dimensions		NADO 300/20 v6	NADO 500/25 v6	NADO 750/35 v6	NADO 1000/45 v6
Tank diameter	∅ d	550	600	750	850
Tank diameter with insulation	∅ D	670	760	910	1010
Total tank height	L	1705	1970	2030	2040
Tilting height	L _k	1715	1990	2050	2060
Discharging connection	A	80	100	100	100
Z/T circuit socket	B	238	262	280	297
Z/T circuit socket	C	-	952	1018	1040
Z/T circuit socket	E	1438	1662	1680	1700
Socket TV – inlet	F	1299	312	320	380
Socket TV – outlet	G	1438	1612	1680	1700
Solar exchanger socket – outlet	I	228	245	270	280
Solar exchanger socket – inlet	J	756	905	884	980
Sensor pocket socket	K	458	392	415	463
Sensor pocket socket	M	1438	762	742	755
Sensor pocket socket	N	-	1282	1219	1213
Sensor pocket socket	O	1348	1662	1680	1700
TJ ¼" heating unit socket	P	816	992	1017	1040
TJ ¼" heating unit socket	R	100	225	290	340

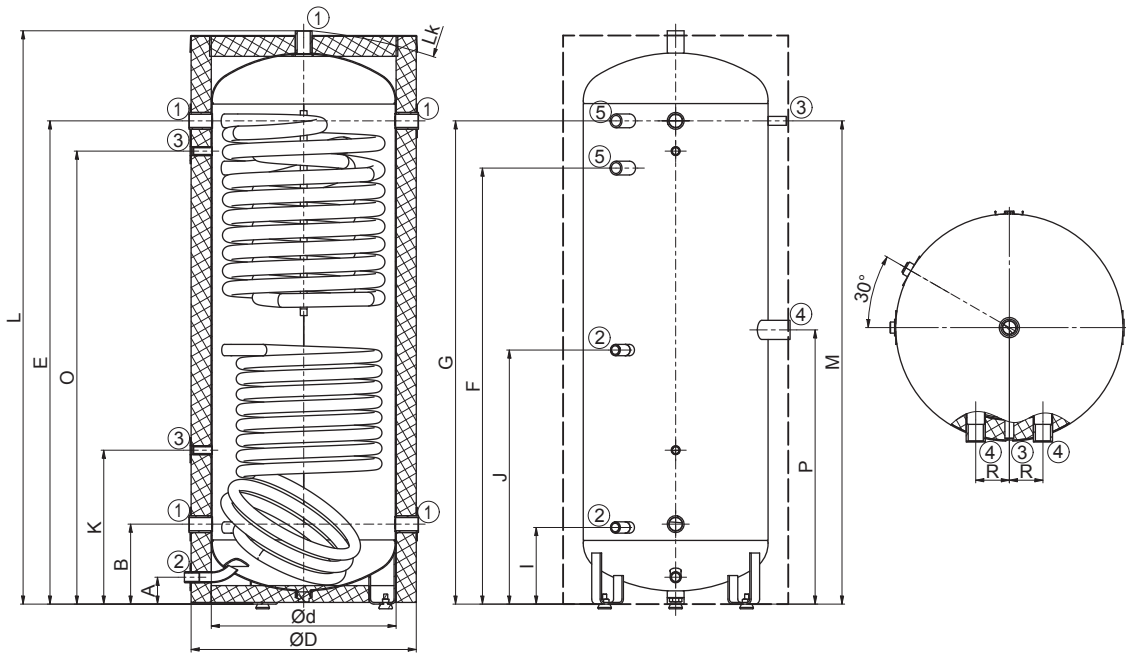

NADO 300/20 v6

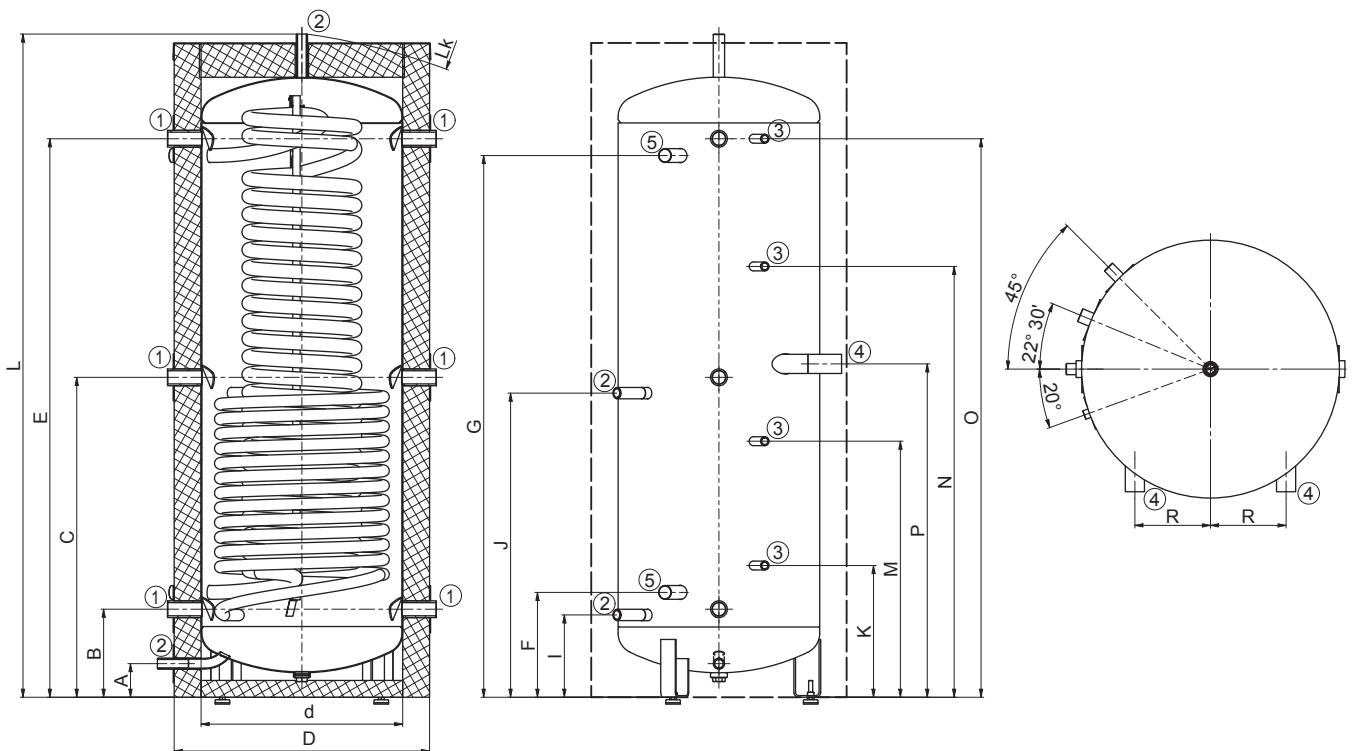

NADO 500, 750, 1000 v6

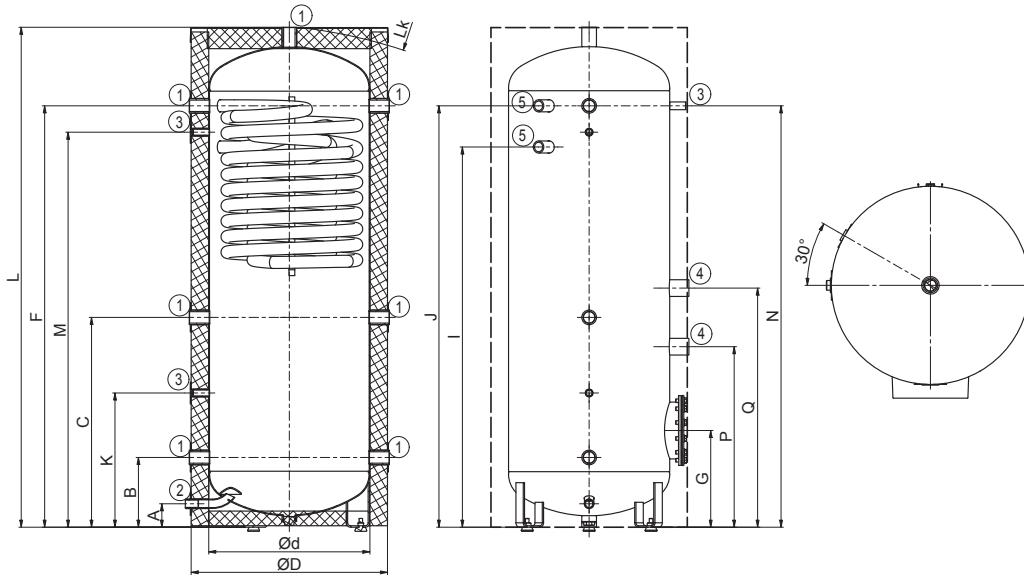

NADO 300, 400/20 v11

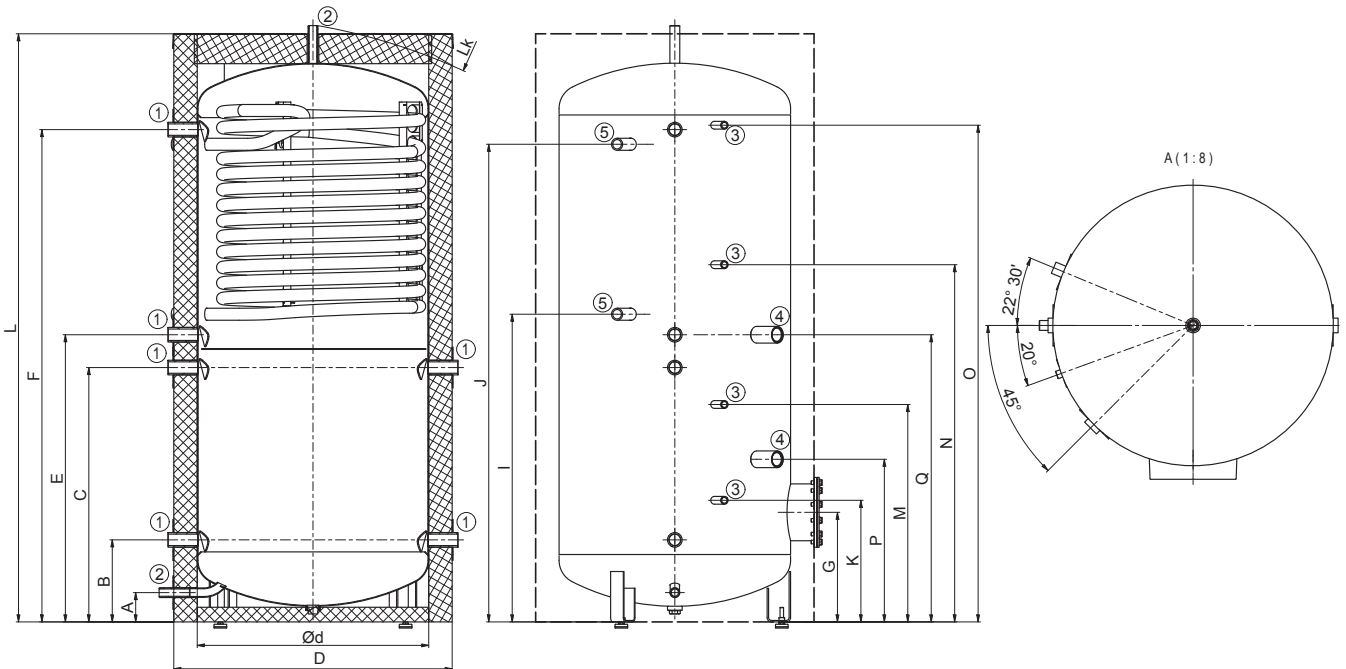

NADO 750, 1000/25 v11



ACCESSORIES

- Delivery of NEODUL variant
- Standard insulation thickness Neodul 80 mm
- Standard insulation in B and C energy classes
- Example of heat loss for 500 l tank: 1.9 kWh / 24 h with an insulation thickness of 80 mm
- The package includes lower and upper covers, flange and opening covers
- The NAD 50, 100, 250 v1 and UKV 300, 500 tanks are supplied with polyurethane insulation
- The fleece parts of the insulation contains 65% plastics from recycled PET bottles

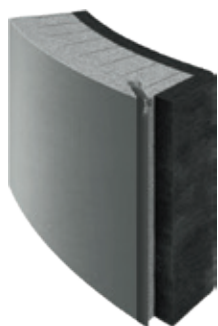

Insulation cut with fastener NEODUL

Informative image



- **Insulation CELLA COOL**
for cooling NAD 750 – 2000 v 15

Informativní obrázek



IPS ProtectX

IPS - IONIZATION POLARIZATION SYSTEM

Equipment for the physical treatment of water in connection with the reduction of limestone for the protection of household appliances and water distribution systems



ADVANTAGES

- It prolongs the service life of heating equipment and sanitary equipment
- No external power supply
- Maintenance free
- Zero additional costs
- It does not use any chemicals
- Negligible pressure losses
- Patented product
- Certified effectiveness
- Blue line - suitable for all types of water supply, in addition it contains disinfectants, suitable e.g. for untreated water sources
- Red line - suitable for all types of water supply

INDICATIVE DIAGRAM OF THE IPS PROTECTX EQUIPMENT LOCATION

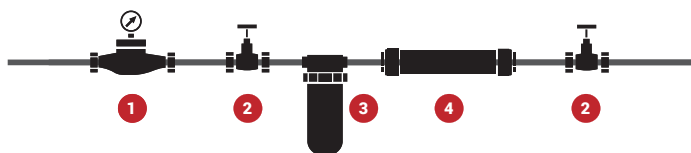

1. Consumption meter
2. Shut-off valve
3. Mechanical dirt filter
4. IPS ProtectX

Order number	TYPE	DIMENSIONS (d × l)	MAXIMUM FLOW
100671000	ProtectX G ½" (red line)	50 × 245 mm	1 m³/h
100671001	ProtectX G ¾" (red line)	50 × 245 mm	3,2 m³/h
100671002	ProtectX G 1" (red line)	50 × 251 mm	4 m³/h
100671003	ProtectX G ½" (blue line)	50 × 245 mm	1 m³/h
100671004	ProtectX G ¾" (blue line)	50 × 245 mm	3,2 m³/h
100671005	ProtectX G 1" (blue line)	50 × 251 mm	4 m³/h

ORIGINAL PARTS FROM DRAŽICE

- 24 month warranty period
- Reliability and high quality
- Guarantee of functionality and safety
- Guaranteed long life
- Identical components used in manufacturing

ANODE WITH EXTERNAL POWER SUPPLY

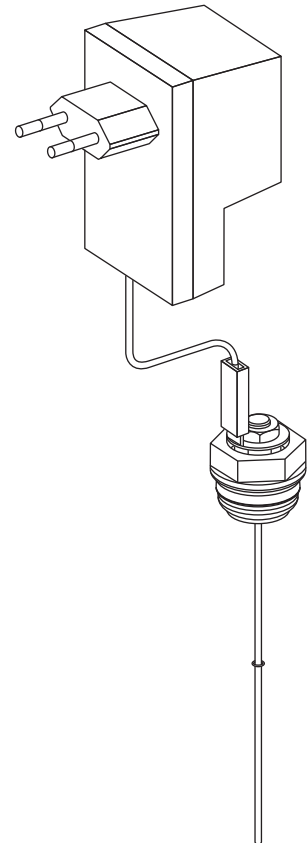
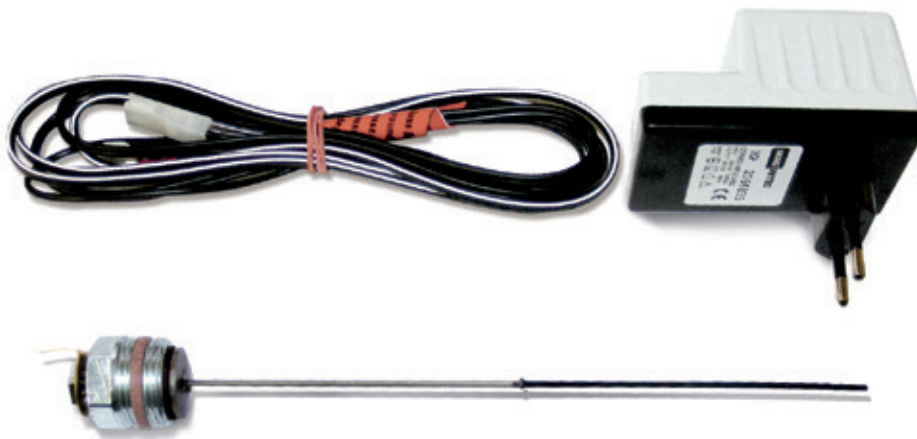

- Used for protection of inner enamel storage tanks and extends their life span
- Usable up to a volume of 300 l
- Maintenance free, wear proof
- To order

Order number	6199209
Diameter	2 mm
Length	200 mm
Coat length	100 mm

NEW

BRASS THERMOWELL

- Available in three different lengths
- For temperature sensors of controllers up to 8 mm diameter
- For the G½" sleeves

Type		TH 90 brass - G½"	TH 135 brass - G½"	TH 180 brass - G½"
Order number		100671300	100671301	100671302
Packaging	pcs	50		
Total length L	mm	90	135	180

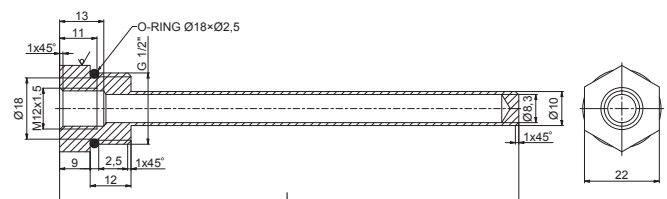

ORIGINAL PARTS FROM DRAŽICE

BIVALENT SOURCE TJ 2"

Type		TJ 2" EHP 9 kW
Order number		2110551
Power consumption	[kW]	3 - 9
Extension length (± 10 mm)	[mm]	520
Weight	[kg]	5,5
Electrical connection		3/N/PE ~ 3× 230 V / 50 Hz, ⤴
Recomm.circuit breaker value	[A]	3 × 16
Degree of protection		IP44

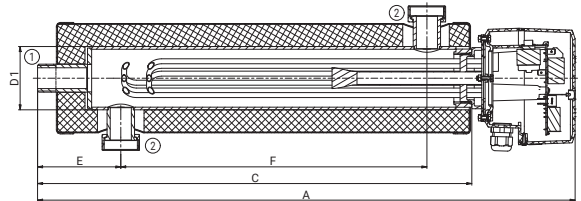
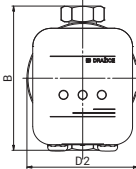

SCREW-TYPE ELECTRICAL HEATING UNITS OF THE TJ SERIES

Type		TJ ¼"-2	TJ ¼"-2,5	TJ ¼"-3,3	TJ ¼"-3,75	TJ ¼" E-3,75	TJ ¼"-4,5	TJ ¼" E-4,5	TJ ¼"-6	TJ ¼" E-6	TJ ¼"-9
Order number		2110353	2110354	2110355	2110356	2110365	2110357	2110366	2110358	2110367	2110360
Power consumption	[kW]	2	2,5	3,3	3,75	3,75	4,5	4,5	6	6	9
Extension length L/L1	[mm]	380	405	325	450	450	500	500	520	520	690
Cold part of the heating unit (± 10 mm)		150	150	60	175	175	150	150	150	150	150
Weight	[kg]	1,2	1,3	1,7	2	2	2	2	2	2	2,3
Electrical connection		1/N/PE ~ 230 V / 50 Hz		3/N/PE ~ 3× 230 V / 50 Hz, ⤴						3/N/PE ~ 400 V / 50 Hz, ⤴	
Recomm.circuit breaker value	[A]	16	16	3 × 10	3 × 10	3 × 10	3 × 10	3 × 10	3 × 16	3 × 16	3 × 20
Degree of protection		IP44									
Scale of set temperature	[°C]	5-74									
Heat. time approx. 150 l 10-60°C	[h]	4,5	4	2,7	2,3	2,3	2	2	1,5	1,5	1

Suitable for photovoltaic applications 

Types TJ ¼"-2 and TJ ¼"-2,5 include flexible supply cable in the socket.

Extension lengths are in a tolerance of ± 10 mm.



TJ ¼"

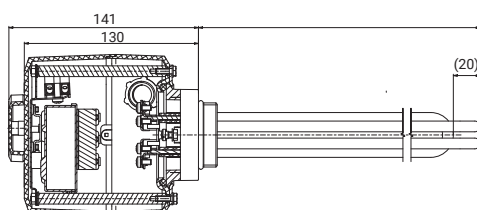



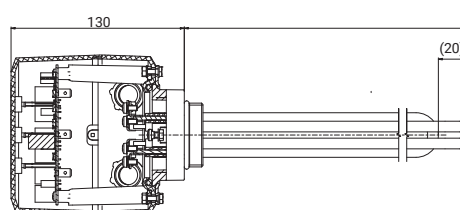



TJ ¼" E



ORIGINAL PARTS FROM DRAŽICE

FLANGED ELECTRICAL HEATING UNITS OF THE TPJ, SE SERIES

Type		 TPJ 150-8/2,5 kW	 TPJ 150-8/3,0 kW	 TPJ 150-8/4,0 kW	 TPJ 150-8/6,0 kW	 TPJ 150-8/7,5 kW	TPJ 150-8/9,0 kW	TPJ 150-8/12 kW	TPJ 150-8/15 kW	SE 377	SE 378
Order number		2110700	2110701	2110702	2110703	2110704	2110705	2110706	2110707	100541517	100541511
Power consumption	[kW]	2,5	3	4	6	7,5	9	12	15	8-11-16	9,5-12,7-19
Weight	[kg]	3	3,5	3,5	3,5	3,7	4	4	4,2	8	11,5
Extension length	[mm]	450						580		610	740
Electrical connection		1/N/PE ~ 230 V/50 Hz	3/N/PE ~ 3× 230 V/50 Hz, Δ			3/N/PE ~ 400 V/50 Hz, Δ					
Recomm. circuit breaker value	[A]	16	3 × 10	3 × 10	3 × 16	3 × 16	3 × 20	3 × 20	3 × 25	3 × 25	3 × 32
Degree of protection		IPX4								IP20	
Heat. time approx. 300 l 10–60 °C	[h]	7	6	4,5	3	2,5	2	1,5	1,3	2 - 2 - 1,3	2 - 1,5 - 1





Suitable for photovoltaic applications 

Extension lengths are in a tolerance of ± 10 mm.



ORIGINAL PARTS FROM DRAŽICE

FLANGED ELECTRICAL HEATING UNITS WITH CERAMIC BODY OF THE TPK SERIES

Type		 TPK 150-8/2,2	 TPK 150-8/3,3 - 1 thermowell	 TPK 210-12/2,2 - 1 thermowell	 TPK 210-12/3,3 - 1 thermowell	 TPK 210-12/6,6	TPK 210-12/9	TPK 210-12/12
Order number		2110409	2110435	2110437	2110436	2110410	2110430	2110414
Power consumption	[kW]	2,2	3,3	2,2	3,3	6,6	9	12
Weight	[kg]	4,2	4,5	6,6	12	13	13,6	14
Extension length	[mm]	400	400	440	440	440	550	550
Electrical connection		1/N/PE ~ 230 V/50 Hz	3/N/PE ~ 3x 230 V/50 Hz, Δ	1/N/PE ~ 230 V/50 Hz	3/N/PE ~ 3x 230 V/ 50 Hz, Δ		3/N/PE ~ 400 V/50 Hz, Δ	
Recomm. circuit breaker value	[A]	16	3 x 10	16	3 x 10	3 x 16	3 x 20	3 x 25
Degree of protection		IP42						
Scale of set temperature	[°C]	5-74						

Suitable for photovoltaic applications 

Extension lengths are in a tolerance of ± 10 mm.



TPK - 3 THERMOWELLS



TPK - 1 THERMOWELL

COMPOSITION OF SINGLE- AND THREE-PHASE TPK HEATING FLANGE UNITS

TPK - SINGLE-PHASE

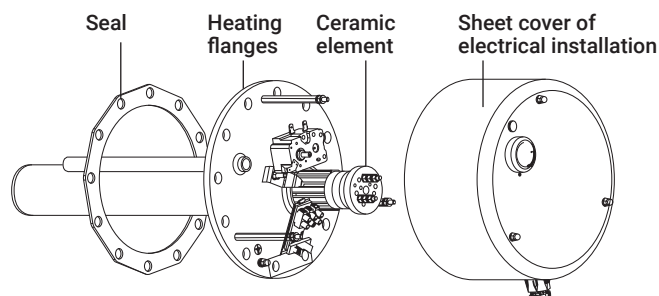

TPK - THREE-PHASE

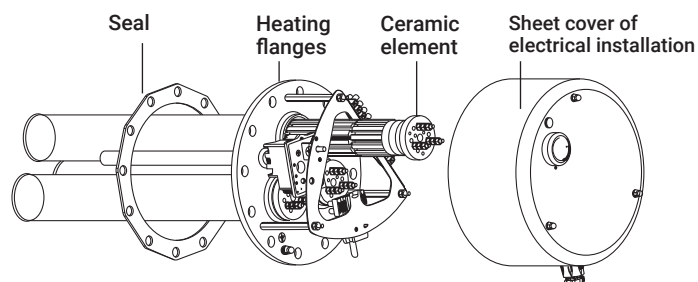

ACCESSORY TABLES

MOUNTING OPTIONS FOR FLANGED ELECTRICAL HEATING UNITS OF THE TPJ SERIES

Type	TPJ 150-8/2,5 kW	TPJ 150-8/3,0 kW	TPJ 150-8/4,0 kW	TPJ 150-8/6,0 kW	TPJ 150-8/7,5 kW	TPJ 150-8/9,0 kW	TPJ 150-8/12 kW	TPJ 150-8/15 kW
NAD 500 v1	●	●	●	●	●	●	●	-
NAD 750 v1	●	●	●	●	●	●	●	●
NAD 1000 v1	●	●	●	●	●	●	●	●
NAD 1500 v1	●	●	●	●	●	●	●	●
NAD 2000 v1	●	●	●	●	●	●	●	●
NAD 500 v3	●	●	●	●	●	●	●	-
NAD 750 v3	●	●	●	●	●	●	●	●
NAD 1000 v3	●	●	●	●	●	●	●	●
NAD 500 v4	●	●	●	●	●	●	-	-
NAD 750 v4	●	●	●	●	●	●	●	-
NAD 1000 v4	●	●	●	●	●	●	●	●
NADO 500/140 v1	●	●	●	●	●	●	●	-
NADO 750/140 v1	●	●	●	●	●	●	●	●
NADO 1000/140 v1	●	●	●	●	●	●	●	●
NADO 500/200 v1	●	●	●	●	●	●	●	-
NADO 750/200 v1	●	●	●	●	●	●	●	●
NADO 1000/200 v1	●	●	●	●	●	●	●	●
NADO 500/140 v2	●	●	●	●	●	●	-	-
NADO 750/140 v2	●	●	●	●	●	●	●	-
NADO 1000/140 v2	●	●	●	●	●	●	●	●
NADO 300/20 v11	●	●	●	●	●	●	-	-
NADO 400/20 v11	●	●	●	●	●	●	-	-
NADO 750/25 v11	●	●	●	●	●	●	●	-
NADO 1000/25 v11	●	●	●	●	●	●	●	●

● can only be fitted with the 210/150 reduction flange, - cannot be fitted

MOUNTING OPTIONS FOR FLANGED ELECTRICAL HEATING UNITS OF THE TPK SERIES

Type	TPK 150-8/2,2 kW	TPK 150-8/3,3 kW	TPK 210-12/2,2 kW	TPK 210-12/3,3 kW	TPK 210-12/6,6 kW	TPK 210-12/9 kW	TPK 210-12/12 kW
NAD 500 v1	-	-	▲	▲	▲	▲	▲
NAD 750 v1	-	-	▲	▲	▲	▲	▲
NAD 1000 v1	-	-	▲	▲	▲	▲	▲
NAD 1500 v1	-	-	▲	▲	▲	▲	▲
NAD 2000 v1	-	-	▲	▲	▲	▲	▲
NAD 500 v3	-	-	▲	▲	▲	▲	▲
NAD 750 v3	-	-	▲	▲	▲	▲	▲
NAD 1000 v3	-	-	▲	▲	▲	▲	▲
NAD 500 v4	-	-	▲	▲	▲	-	-
NAD 750 v4	-	-	▲	▲	▲	▲	▲
NAD 1000 v4	-	-	▲	▲	▲	▲	▲
NADO 500/140 v1	-	-	▲	▲	▲	▲	▲
NADO 750/140 v1	-	-	▲	▲	▲	▲	▲
NADO 1000/140 v1	-	-	▲	▲	▲	▲	▲
NADO 500/200 v1	-	-	▲	▲	▲	▲	▲
NADO 750/200 v1	-	-	▲	▲	▲	▲	▲
NADO 1000/200 v1	-	-	▲	▲	▲	▲	▲
NADO 500/140 v2	-	-	▲	▲	▲	-	-
NADO 750/140 v2	-	-	▲	▲	▲	▲	▲
NADO 1000/140 v2	-	-	▲	▲	▲	▲	▲
NADO 300/20 v11	-	-	▲	▲	▲	-	-
NADO 400/20 v11	-	-	▲	▲	▲	-	-
NADO 750/25 v11	-	-	▲	▲	▲	▲	▲
NADO 1000/25 v11	-	-	▲	▲	▲	▲	▲

▲ can be fitted, - cannot be fitted

ACCESSORY TABLES

MOUNTING OPTIONS FOR SCREW-TYPE ELECTRICAL HEATING UNITS OF THE TJ SERIES

Type	TJ 9/16" - 2 *	TJ 9/16" - 2,5 *	TJ 9/16" - 3,3	TJ 9/16" - 3,75 *	TJ 9/16" E - 3,75 *	TJ 9/16" - 4,5 *	TJ 9/16" E - 4,5 *	TJ 9/16" - 6 *	TJ 9/16" E - 6 *	TJ 9/16" - 9 *
NAD 50 v1	▲	▲	▲	-	-	-	-	-	-	-
NAD 100 v1	▲	▲	▲	▲	▲	▲	▲	▲	▲	-
NAD 200 v1	▲	▲	▲	▲	▲	▲	▲	▲	▲	-
NAD 500 v1	▲	▲	▲	▲	▲	▲	▲	▲	▲	-
NAD 750 v1	▲	▲	▲	▲	▲	▲	▲	▲	▲	▲
NAD 1000 v1	▲	▲	▲	▲	▲	▲	▲	▲	▲	▲
NAD 1500 v1	▲	▲	▲	▲	▲	▲	▲	▲	▲	▲
NAD 2000 v1	▲	▲	▲	▲	▲	▲	▲	▲	▲	▲
NAD 500 v2	▲	▲	▲	▲	▲	▲	▲	▲	▲	-
NAD 750 v2	▲	▲	▲	▲	▲	▲	▲	▲	▲	▲
NAD 1000 v2	▲	▲	▲	▲	▲	▲	▲	▲	▲	▲
NAD 1500 v2	▲	▲	▲	▲	▲	▲	▲	▲	▲	▲
NAD 2000 v2	▲	▲	▲	▲	▲	▲	▲	▲	▲	▲
NAD 300 v3	▲	▲	▲	▲	▲	▲	▲	▲	▲	-
NAD 500 v3	▲	▲	▲	▲	▲	▲	▲	▲	▲	-
NAD 750 v3	▲	▲	▲	▲	▲	▲	▲	▲	▲	▲
NAD 1000 v3	▲	▲	▲	▲	▲	▲	▲	▲	▲	▲
NAD 500 v4	▲	▲	▲	▲	▲	▲	▲	▲	▲	-
NAD 750 v4	▲	▲	▲	▲	▲	▲	▲	▲	▲	▲
NAD 1000 v4	▲	▲	▲	▲	▲	▲	▲	▲	▲	▲
NAD 200 v15	▲	▲	▲	▲	▲	▲	▲	▲	▲	-
NAD 300 v15	▲	▲	▲	▲	▲	▲	▲	▲	▲	-
NAD 500 v15	▲	▲	▲	▲	▲	▲	▲	▲	▲	▲
NAD 750 v15	▲	▲	▲	▲	▲	▲	▲	▲	▲	▲
NAD 1000 v15	▲	▲	▲	▲	▲	▲	▲	▲	▲	▲
NAD 1500 v15	▲	▲	▲	▲	▲	▲	▲	▲	▲	▲
NAD 2000 v15	▲	▲	▲	▲	▲	▲	▲	▲	▲	▲
NADO 500/140 v1	▲	▲	▲	▲	▲	▲	▲	▲	▲	-
NADO 750/140 v1	▲	▲	▲	▲	▲	▲	▲	▲	▲	▲
NADO 1000/140 v1	▲	▲	▲	▲	▲	▲	▲	▲	▲	▲
NADO 500/140 v2	▲	▲	▲	▲	▲	▲	▲	▲	▲	-
NADO 750/140 v2	▲	▲	▲	▲	▲	▲	▲	▲	▲	▲
NADO 1000/140 v2	▲	▲	▲	▲	▲	▲	▲	▲	▲	▲
NADO 300/20 v6	▲	▲	-	▲	▲	▲	▲	-	▲	-
NADO 500/25 v6	▲	▲	-	▲	▲	▲	▲	▲	▲	-
NADO 750/35 v6	▲	▲	-	▲	▲	▲	▲	▲	▲	-
NADO 1000/45 v6	▲	▲	-	▲	▲	▲	▲	▲	▲	-
NADO 300/20 v11	▲	▲	▲	▲	▲	▲	▲	▲	▲	-
NADO 400/20 v11	▲	▲	▲	▲	▲	▲	▲	▲	▲	-
NADO 750/25 v11	▲	▲	▲	▲	▲	▲	▲	▲	▲	▲
NADO 1000/25 v11	▲	▲	▲	▲	▲	▲	▲	▲	▲	▲
NADS 800 v3	▲	▲	▲	▲	▲	▲	▲	▲	▲	▲
NADOS 800/140 v1	▲	▲	▲	▲	▲	▲	▲	▲	▲	▲
NADOS 800/140 v2	▲	▲	▲	▲	▲	▲	▲	▲	▲	▲

* with extended cold side, ▲ can be fitted, - cannot be fitted

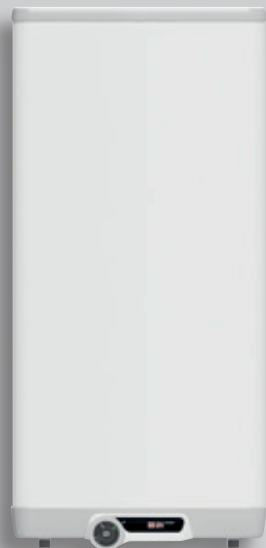

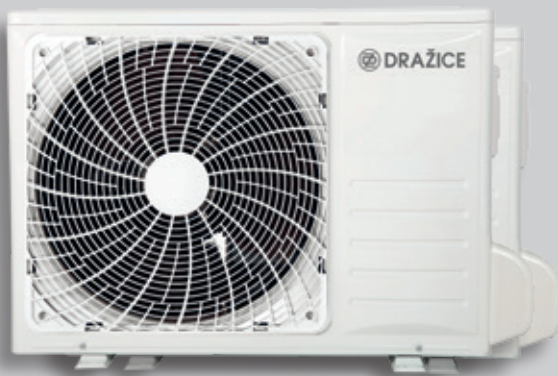

ANOTHER ASSORTMENT

PHOTOVOLTAICS

WATER HEATERS

AIR CONDITION

Complete photovoltaic solutions for your house.

More information can be found at www.dzd-solar.cz.



There is over 380 types of water heaters in product portfolio of Dražice.
Volume from 5l up to 1000l

Standart assortment - following the type of installation

- wall-mounted – vertically or horizontally
- floor-standing

Other assortment - following the type of heat source:

- electric
- combined
- indirect



More information can be found at www.dzd.cz/en/ohrivace-a-zasobniky-teple-vody

SPLIT AIR is an air conditioner with one indoor unit designed for flats, family houses, offices or smaller facilities.

The air conditioner consists of an outdoor unit, one indoor unit and a smart remote controller.

All three performance variants of the AIR air conditioner offer

- cooling
- heating
- a fan
- drying



More information can be found at <https://dzd.cz/en/klimatizacni-jednotky>

The Multisplit AIR PLUS air conditioners are designed for systems with a requirement for more indoor units.

In this solution, one suitably dimensioned outdoor unit is supplemented by two to four indoor units of identical or different outputs so that the requirements of the project are optimally met.

By combining three types of outdoor units and four types of indoor units, practically any configuration of cooling and heating systems can be achieved exactly according to your needs.

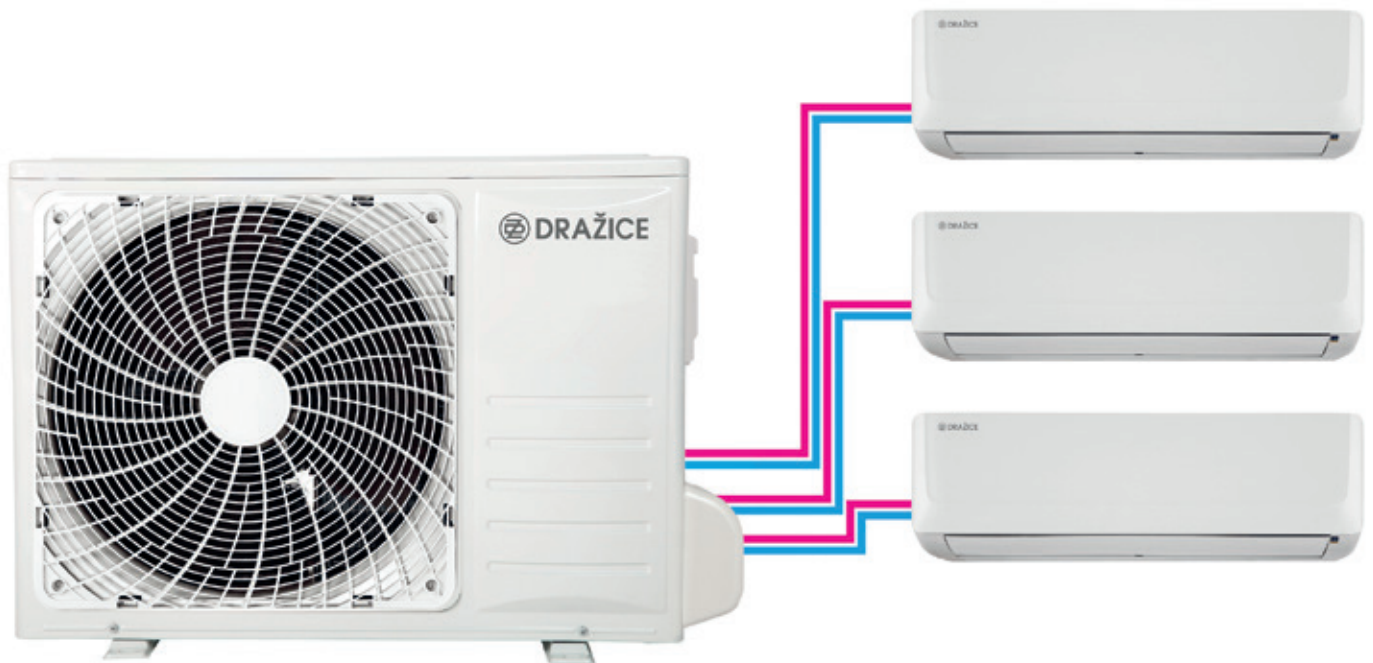

More information can be found at <https://dzd.cz/en/klimatizacni-jednotky>

DRUŽSTEVNÍ ZÁVODY DRAŽICE-STROJÍRNA s.r.o.

Dražice 69, 294 71 Benátky nad Jizerou
Czech Republic

tel.: +420/326 370 961

e-mail: export@dzd.cz

www.dzd.cz/en

